

Quarry Monitor Class Workbook

Certified Inspector
Training Program

Quarry Monitor Workbook

Table of Contents

Click on the section name below to be taken to the correct page.

1. Introduction
2. Geology of Kansas
3. Basic Aggregate Geology
4. Crushed Aggregate production - KAPA
5. Sand Aggregate Production - KAPA
6. Part V
7. KDOT Specifications
8. Mapping and GPS
9. Rip Rap
10. Aggregate Sampling
11. OGCA Aggregate Sampling
12. Aggregate Testing
13. Aggregate Durability
14. AWP
15. Communication
16. Quarry Video

QUARRY INSPECTION CLASS INTRODUCTION TO THE COURSE



1

		Outline
<u>Topic and Sections</u>	<u>Responsible Party</u>	<u>Est. Time</u>
1. Introduction – Class Outline	Chris Leibrock	5 min
2. Geology of Kansas	Kyle Halverson	30 min
3. Basic Aggregate Geology	Kyle Halverson	30 min
4. Crushed Aggregate Production	KAPA Volunteer	60 min
5. Sand Aggregate Production	KAPA Volunteer	60 min
6. Part V Construction Manual	Chris Leibrock	70 min
7. KDOT Specifications	Chris Leibrock	25 min
8. Mapping & GPS	Dan Zirkle	20 min
9. Rip Rap	Leibrock/Halverson	30 min
10. Aggregate Sampling	Leibrock/Halverson	35 min
11. OGCA Sampling	Leibrock/Halverson	30 min
12. Aggregate Testing	Chris Leibrock	40 min
13. Aggregate Durability	Chris Leibrock	50 min
14. CMS/AWP	Dan Zirkle	20 min
15. Communication	Leibrock/Halverson	20 min
16. Quarry Tour Video	Kyle Halverson	15 min

2

- Instructors:
 - Chris Leibrock, PE
 - Assistant Bureau Chief, Materials
 - Kyle Halverson, PG
 - Chief Geologist
 - Dan Zirkle
 - Data Administrator, Materials
 - Steve Hatfield
 - Retired
 - Bill Beggs
 - Martin Marietta

3

- Watch the videos.
- Ask questions online in chat area.
- Exam is multiple choice and online.
- Good luck!

4

Quarry Inspection CIT Class

Kansas Geology

Member	Formation	Lansing Group	MISSOURIAN STAGE	UPPER PENN. SERIES	PENN. SUBSYST.	CARBONIFEROUS SYS.	PALEOZOIC ERA
South Bend Ls. Mbr. Rock Lake Shale Mbr. Stoner Limestone Mbr. Eudora Shale Member Captain Creek Ls. Mbr.	Stanton Limestone						
Spring Hill Ls. Mbr. Hickory Creek Sh. Mbr. Merriam Limestone Mbr.	Plattsburg Limestone						

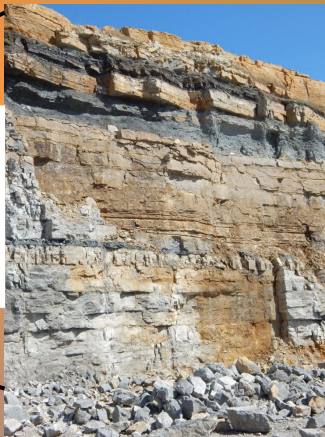

Kyle Halverson
Topeka Regional Geologist

1

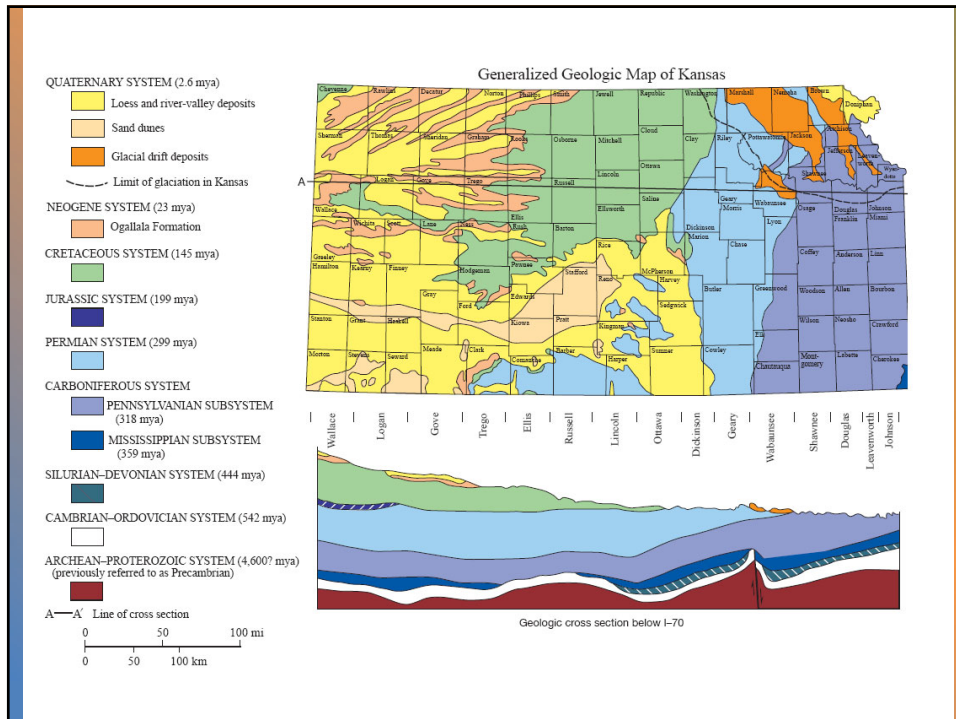

2

Districts within the State

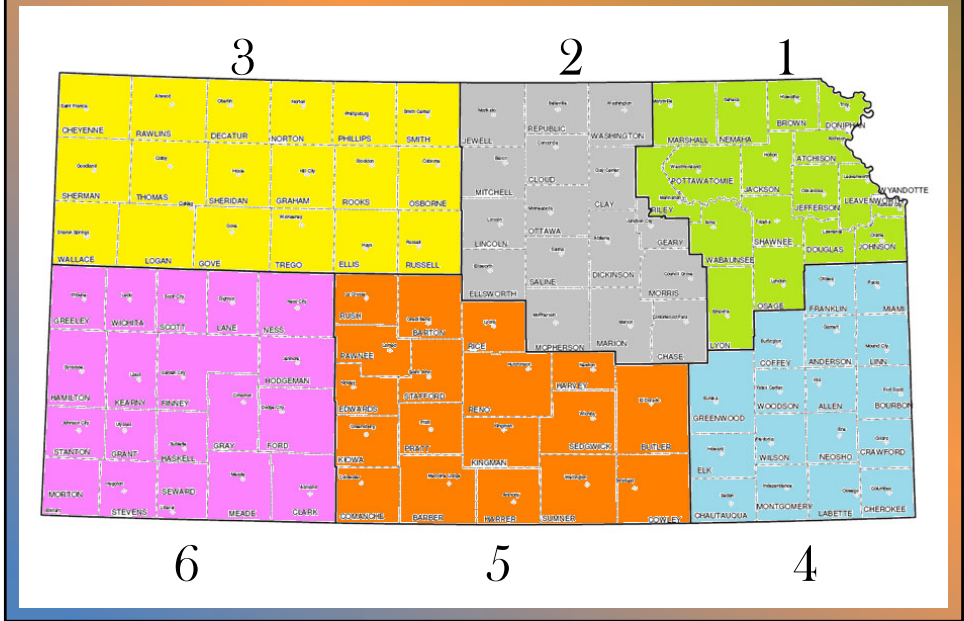

3

District III and VI

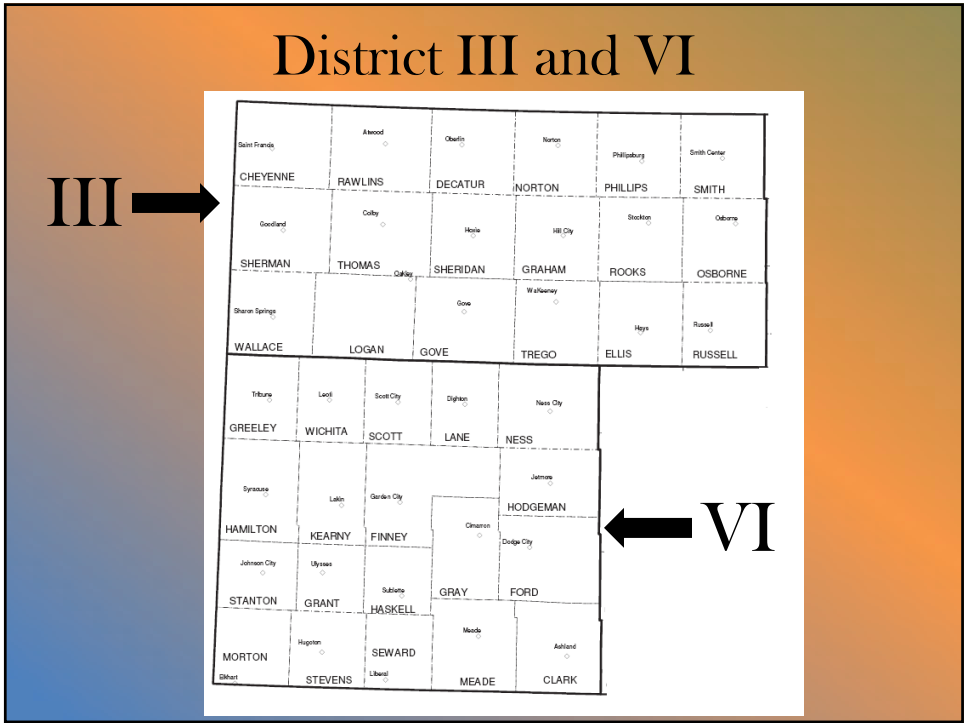

4



5

View from Mount Sunflower Elevation 4039



6



7

Volcanic Ash Deposits

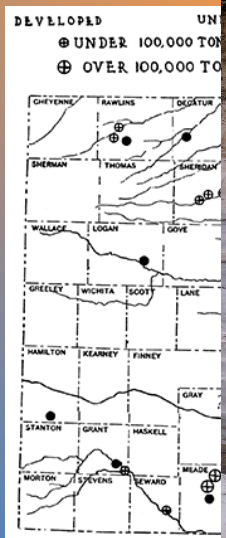

www.geographer-miller.com

8

Ancient North American Sea 65 to 135 million years ago



9

Camel Rock Kiowa County



10

Arikaree Breaks Cheyenne CO.



11



12



13

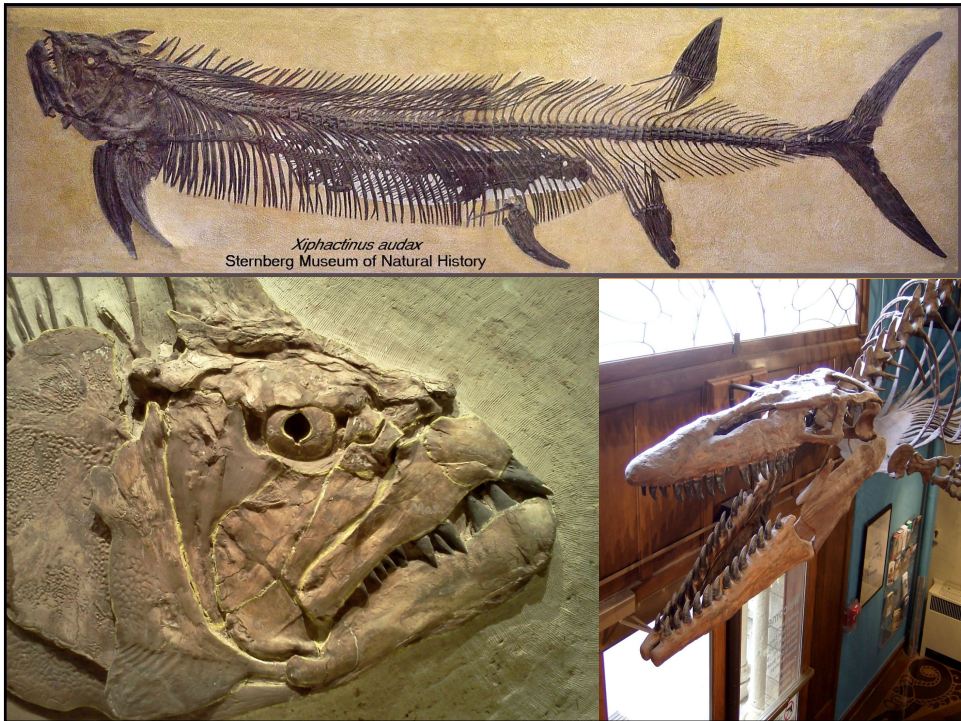

14



15



16

District II and V

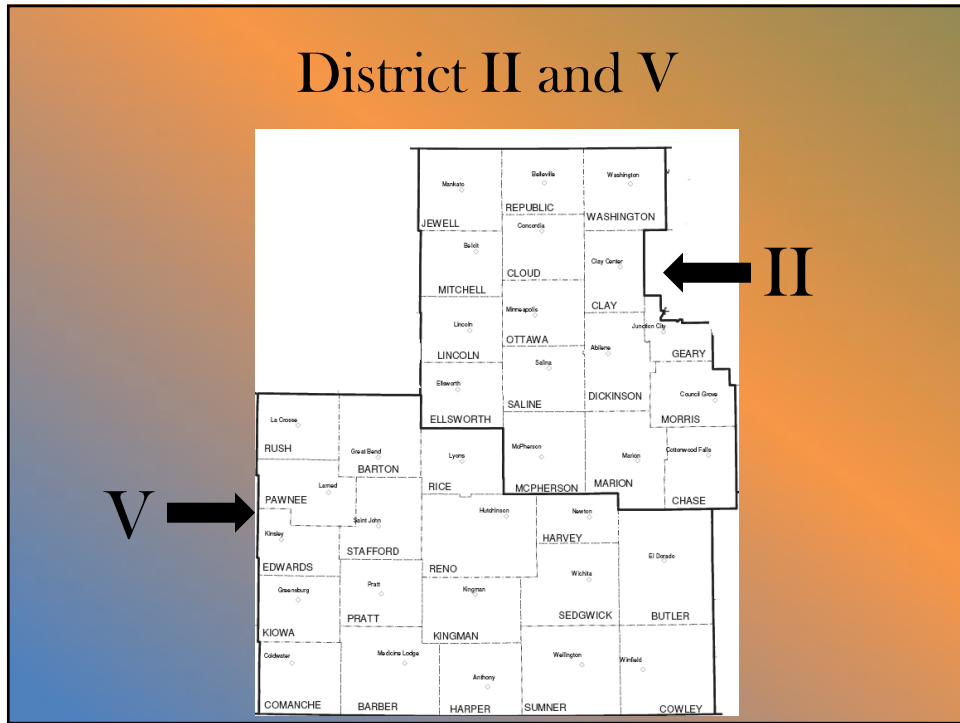

17



18

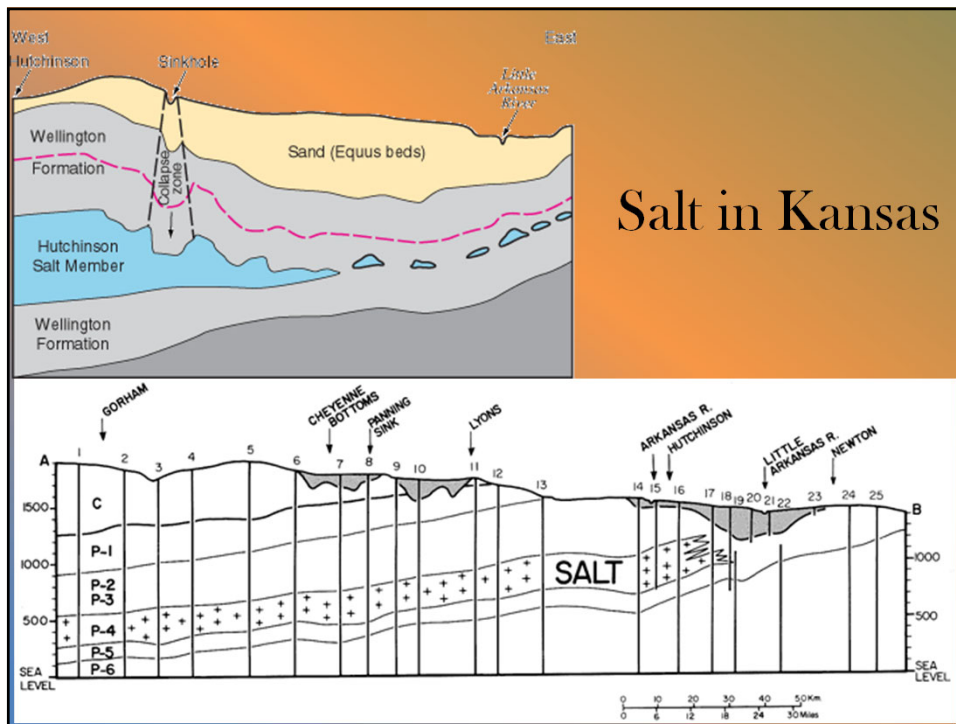

Salt in Kansas

19

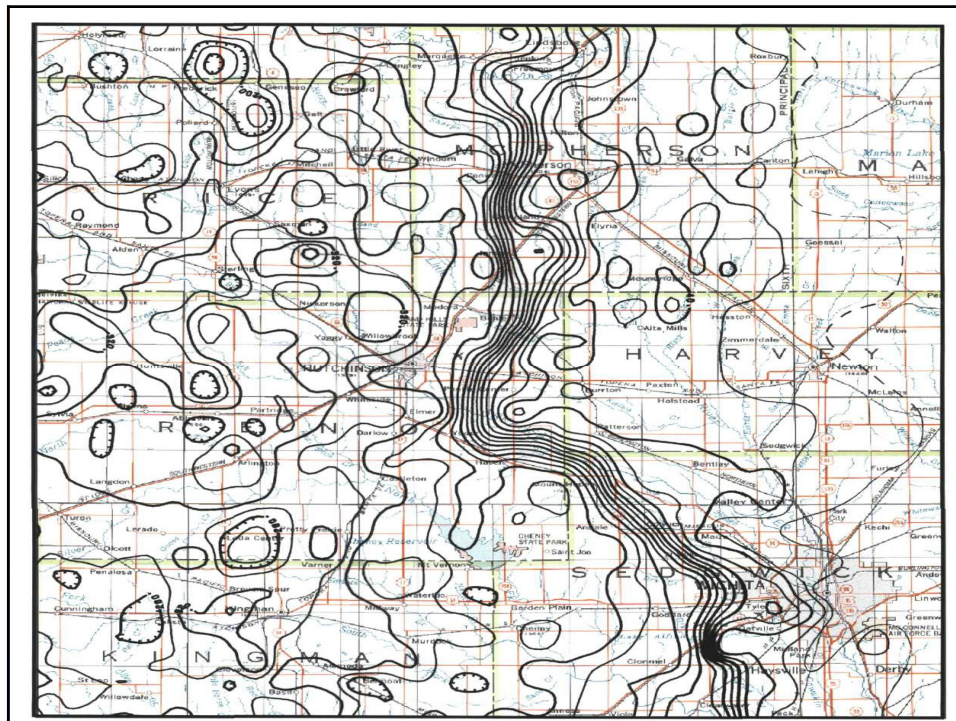

20

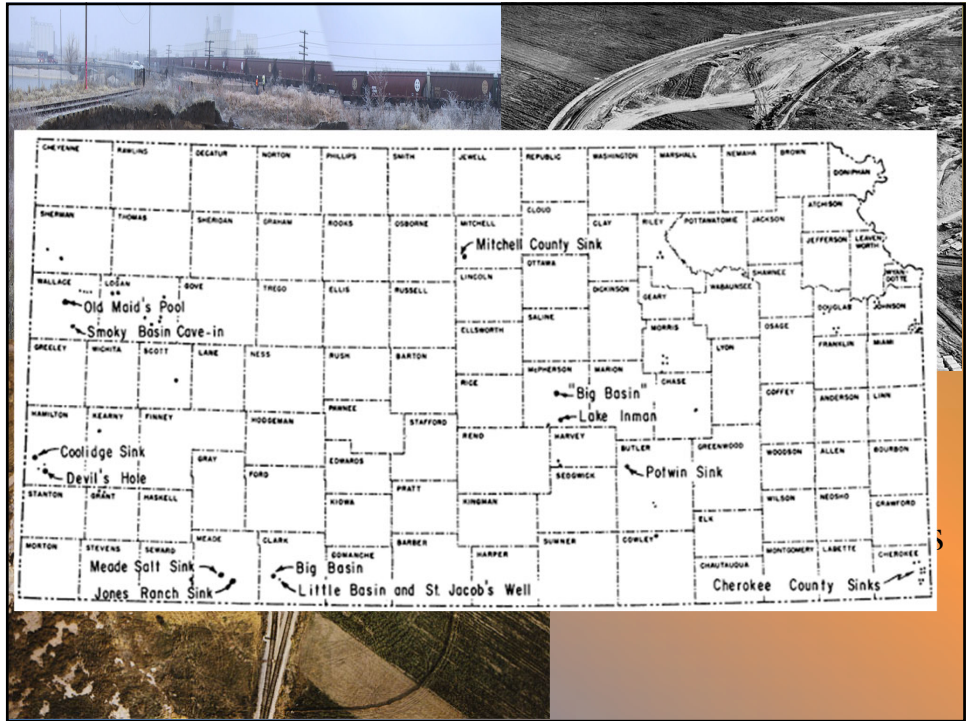

21



22

Green Rock?

- District 2 has some unique deposits of Opaline Cemented Sandstone.
- The opal or chert cement is green.
- This material is commonly used for rip-rap on western Kansas lakes and as a concrete aggregate.

23

Where you
can find the
Green Rock!

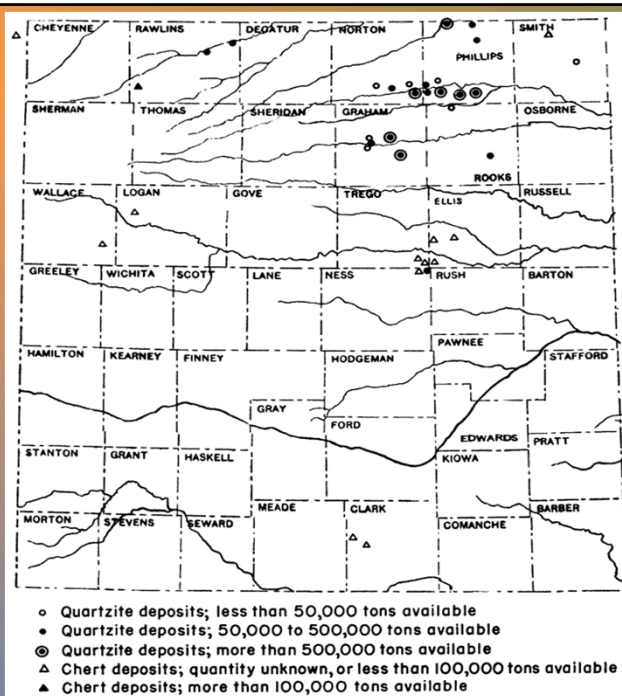

24



25

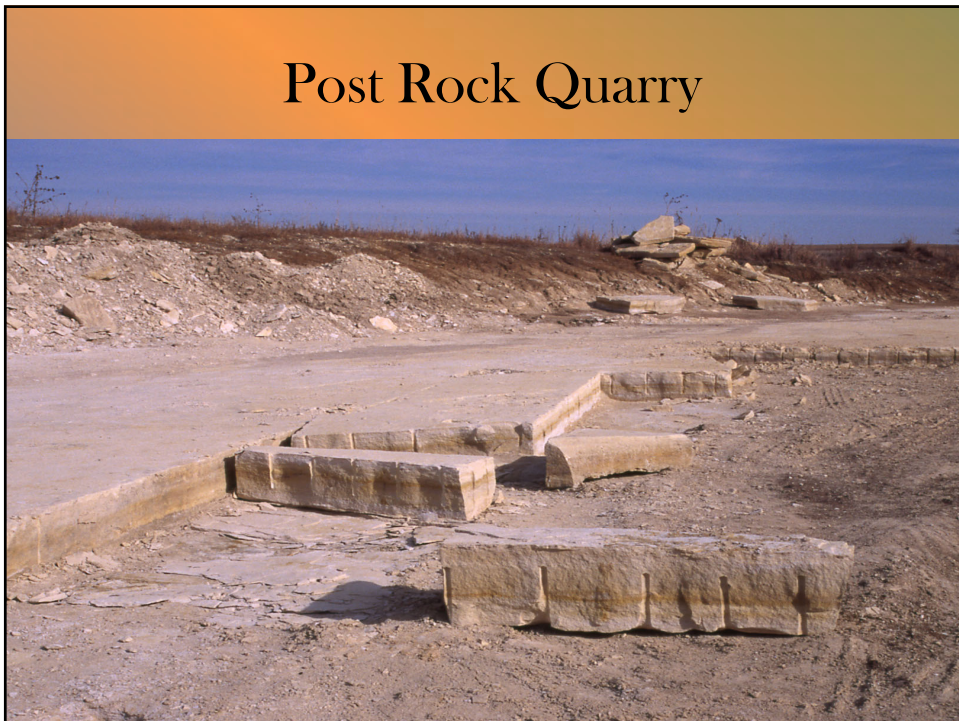

26

Sand Dunes



27

Districts I and IV

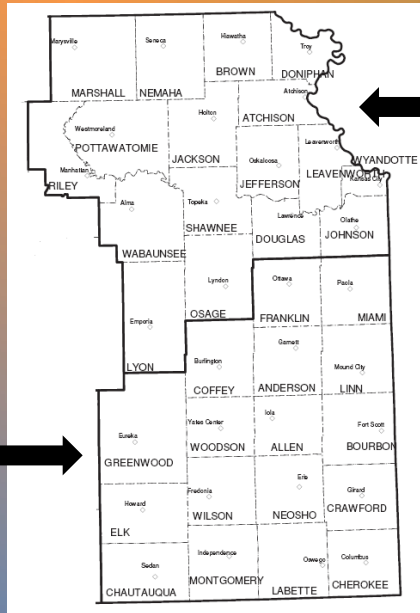

28



29

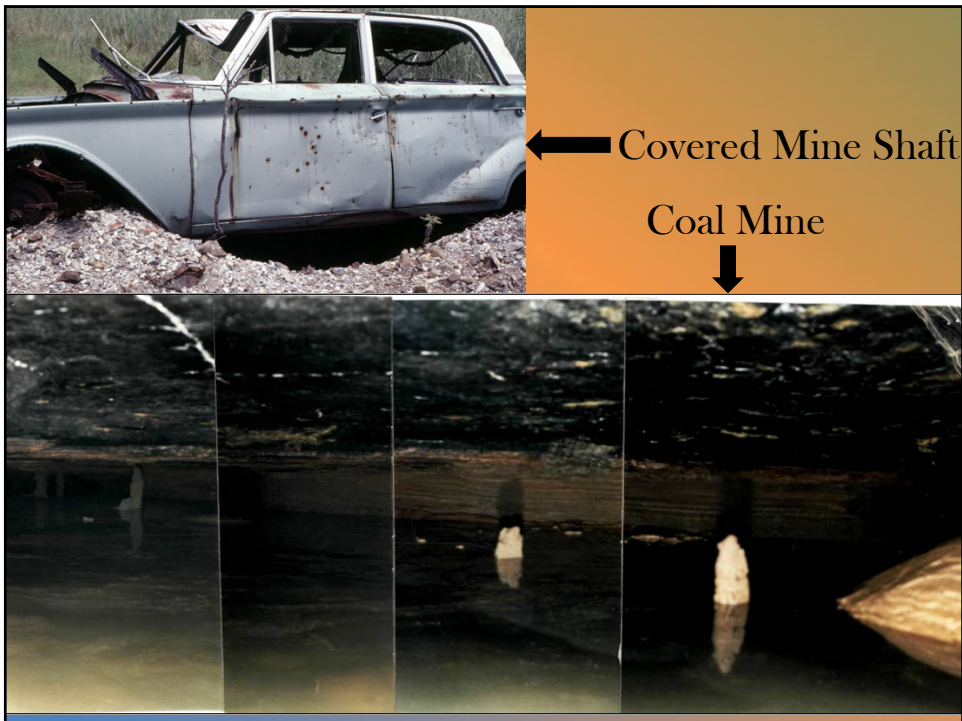

30



31



32

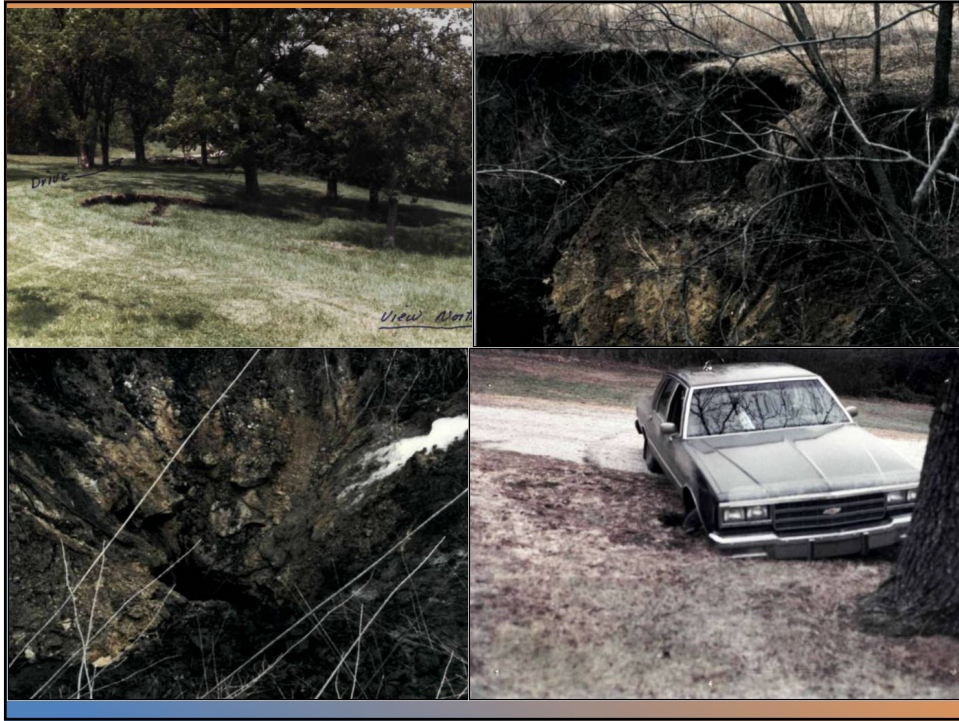

33



34

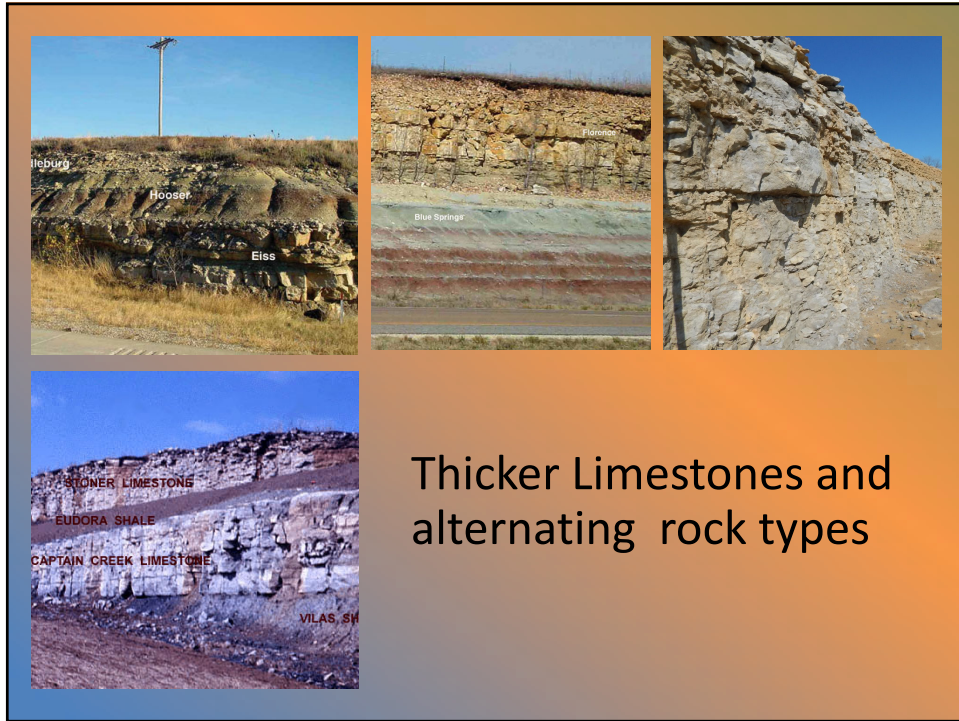

35

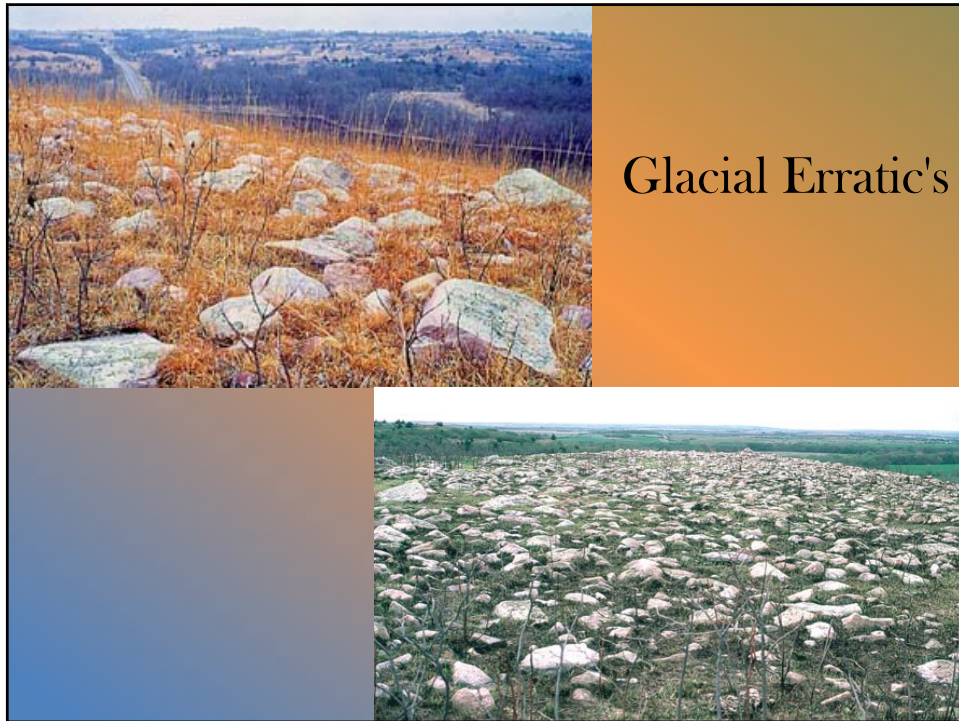

36

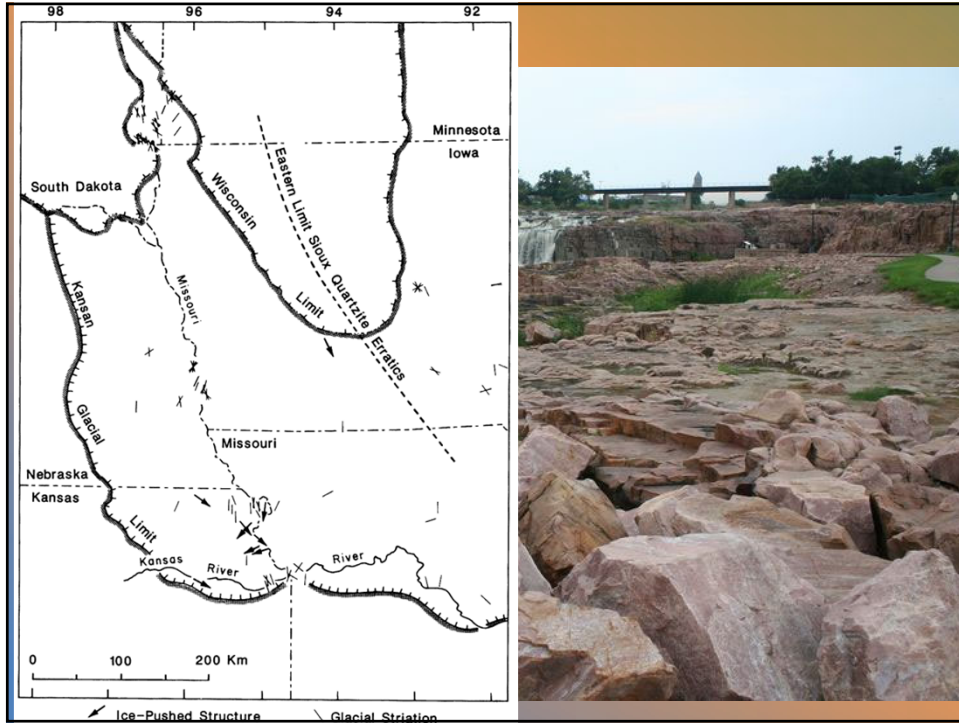

37

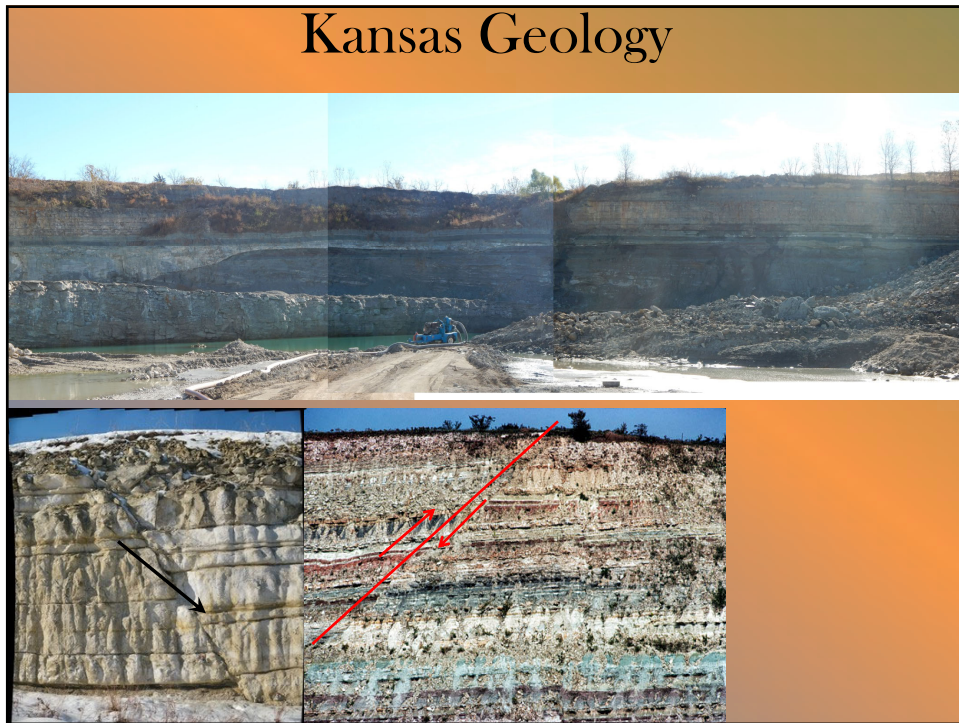

38

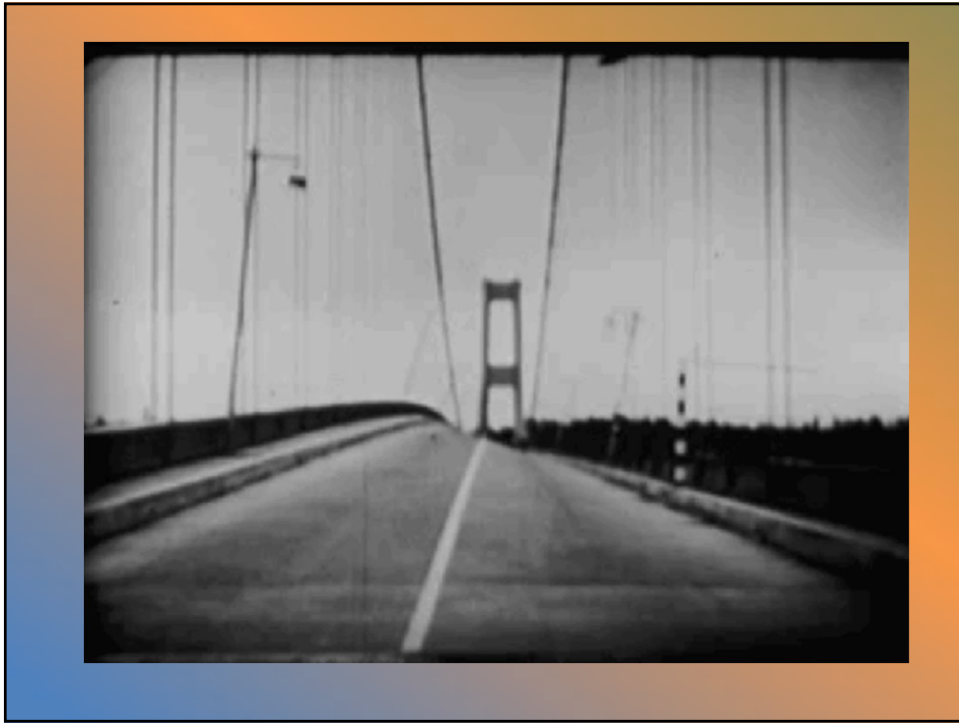

39

Basic Aggregate Geology



1

Crushed Aggregate Types used in Kansas

- Limestone- Kansas (Most common)
- Granite- Missouri, and Colorado
- Rhyolite- Missouri
- Nepheline Syenite- Arkansas
- Dolomite- Oklahoma

2

Limestone

- Calcium Carbonate – CaCO_3
- Comprises more than 4% of earth's crust
- Produced by the sedimentation of the shells of small fossilized snails, shellfish, and coral over millions of years
- By far the most abundantly available coarse aggregate in Kansas
- Is crystalline in structure but has tiny little pores that let water in – and that's the problem...

3

3



4

Grain Size

- Limestones are listed as fine to very course grained.



5

5

Fine to Very Fine Grained



6

6

Bedding

- Bedding can be listed as :
- Unit
- Massive
- Thick
- Medium
- Thin
- Wavy,
- Intermittent



7

Fossils

- Hand specimens to microscopic

8

8



9



10

Brachiopods

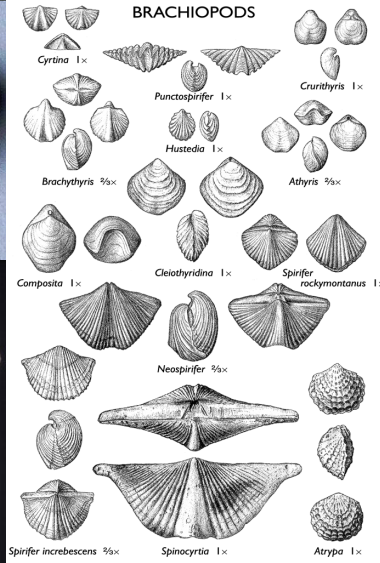

11

11

Phylloid Algae

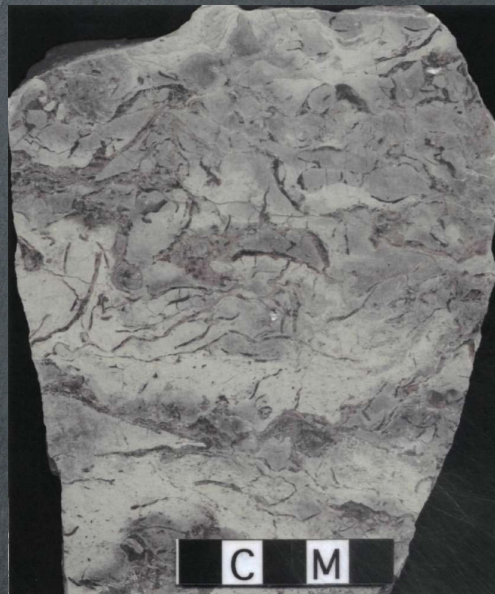

12

12

Corals



13

13

Fusulinids



14

14

Bivalve-Clams



15

15

Trilobites



16

16

Dendrites- Secondary Mineralization



17

17

Limestone with secondary mineralization



18

Limestone with various pore sizes



19

19

Limestone with various pore sizes
cont.



20

20

Microscopic View of Limestone Pores



21

Granite

- Granites are an igneous rock made of the minerals, quartz, feldspars, biotite and many other minerals.
- Very common in the Rocky Mountains
- Extremely variable based on the chemical make-up of the molten material
- Very good aggregate used nation wide.

22

22

Granite-blocks



23

Rhyolite-Trap Rock

- Trap Rock is generic term used to describe Granites, Rhyolite and Basalts that have a distinctive hexagonal pillar structure as they cool.
- The trap rock brought into Kansas is from Iron Mountain Missouri.

24

24

Rhyolite- AKA-Trap Rock



25

25

Nepheline Syenite

- This is a silica starved granite.
- It has less than 10 percent quartz
- Common in the Arkansas-Ouachita Mountain range.
- Makes very good aggregate as it has an extremely low possibility for alkali-silica reactions

26

26

Nepheline Syenite sample



27

27

Dolomite

- Calcium Magnesium Carbonate – $\text{CaMgCo}_3)_2$
- It is thought to form by the post-depositional alteration of lime mud and limestone by magnesium-rich groundwater.
- Dolomite and limestone are very similar rocks.
- They are approximately the same hardness and they are both soluble in dilute hydrochloric acid.
- They are both crushed and cut for use as construction materials and used for their ability to neutralize acids.

28

28

Dolomite-Ledges



29

Other Aggregates used in Kansas

- Quartzites- Metamorphic rock that is derived from sandstone
 - Quartzites in Kansas can come from glacier deposits and shipped in from places like South Dakota
- Lincoln Quartzite- A sedimentary rock that is cemented together by a silica rich cement.
 - It is from very localized deposits in central portion of the state.
- River Gravels-most common source for crushed gravel
 - The river gravels can be made up of rocks from various locations and a host of local rocks.
 - Common rocks are granites, basalts, and limestones

30

30



31



32

CRUSHING

by

Frank Rockers
Mid-States Materials

1

**What's _____
in
a
Ledge?**



2

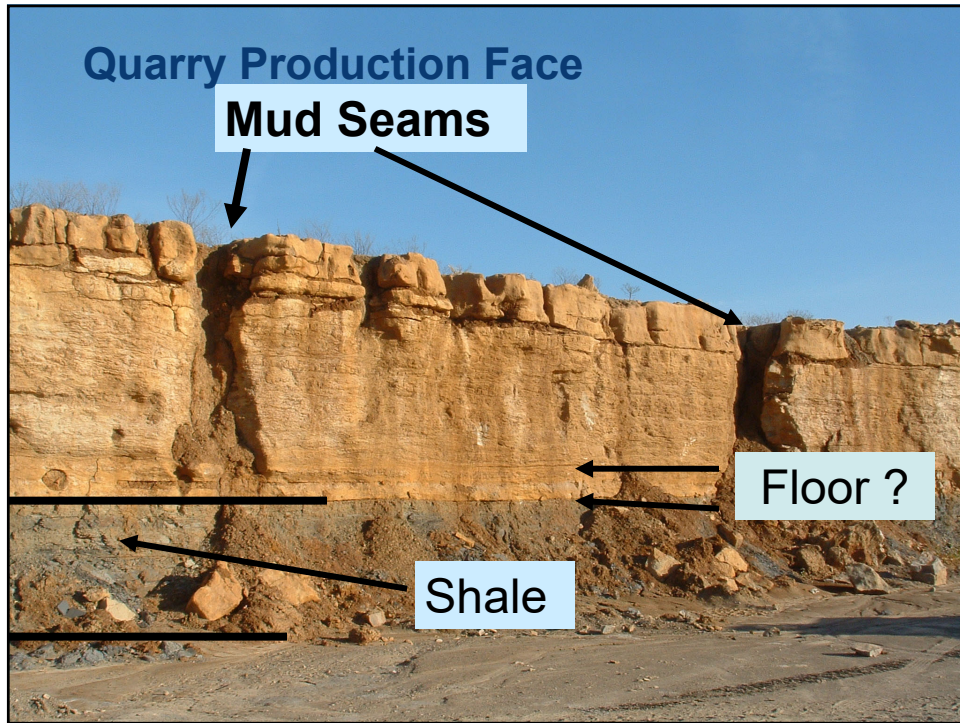

3

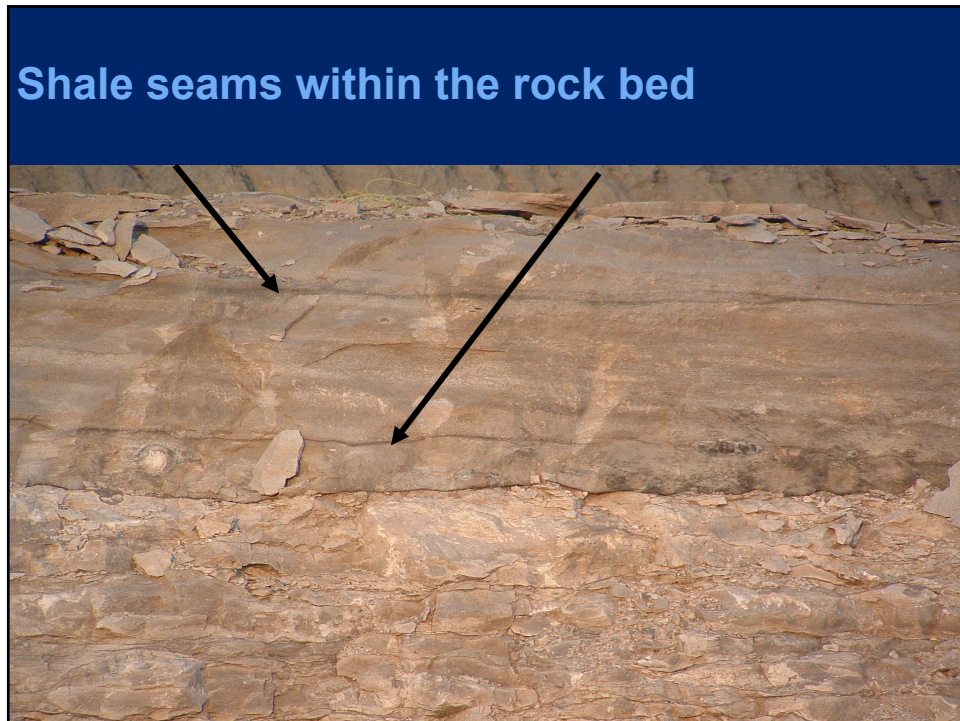

4

Ledge Changes



5

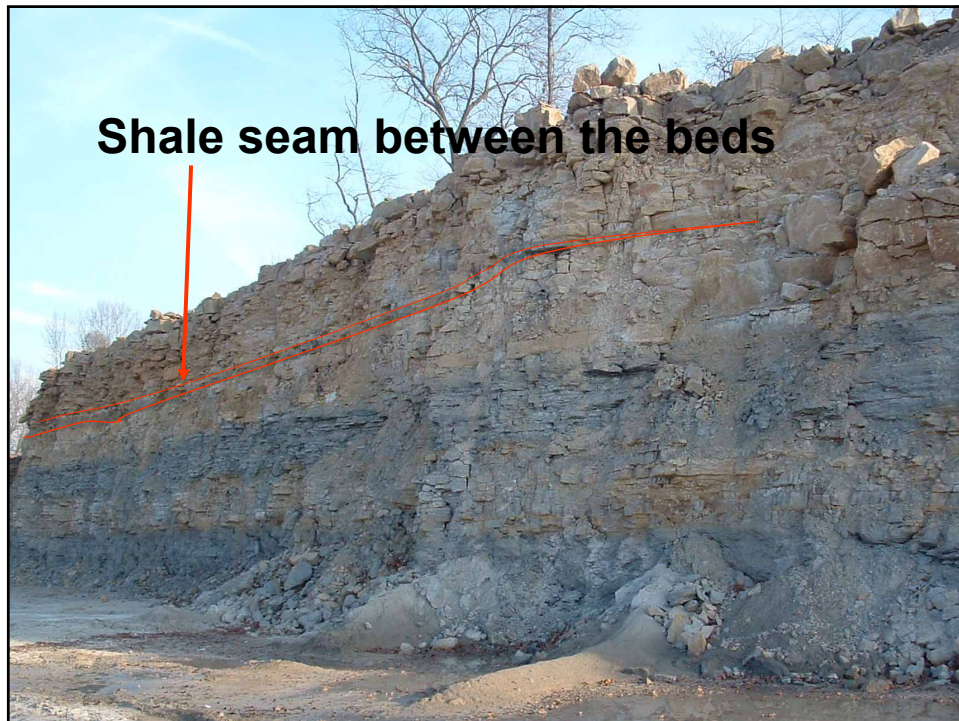

6

Argentine Ledge Beds 1, 2, & 3



7

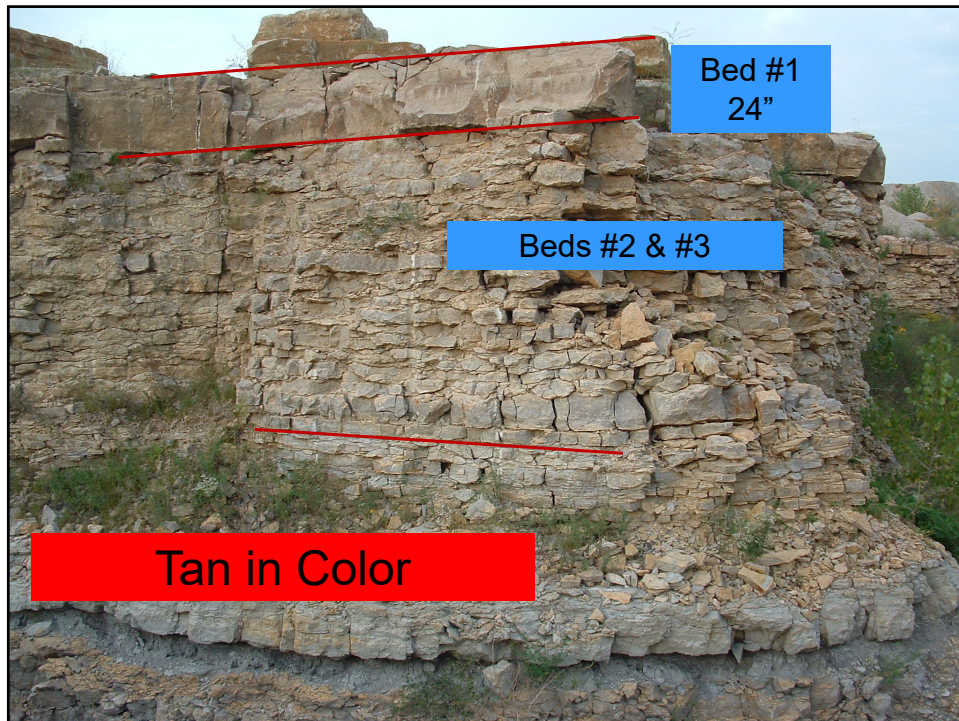

8

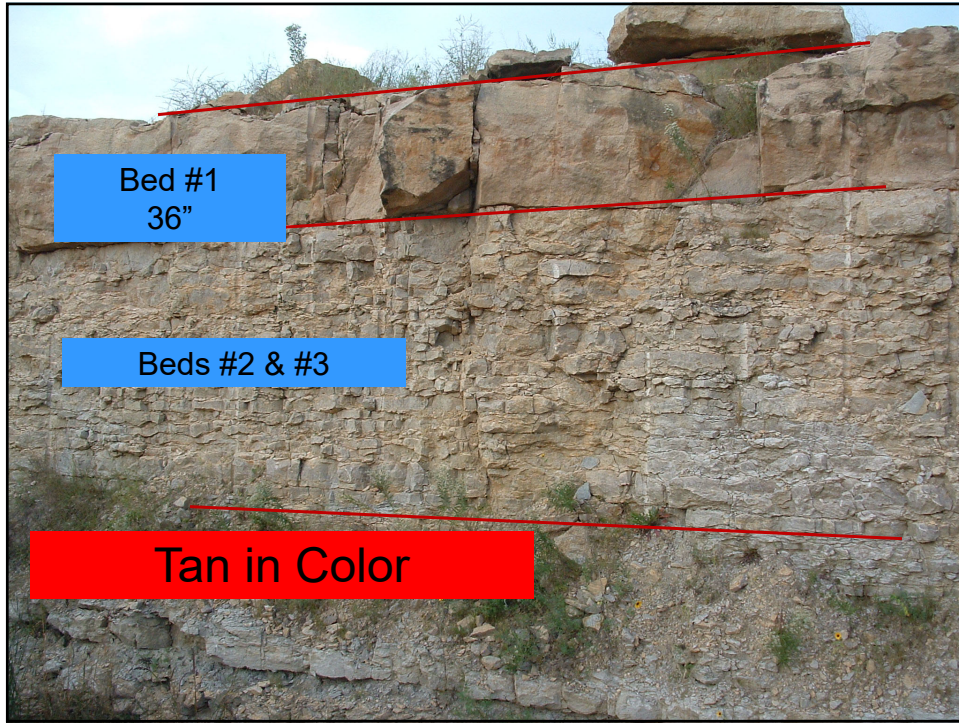

9

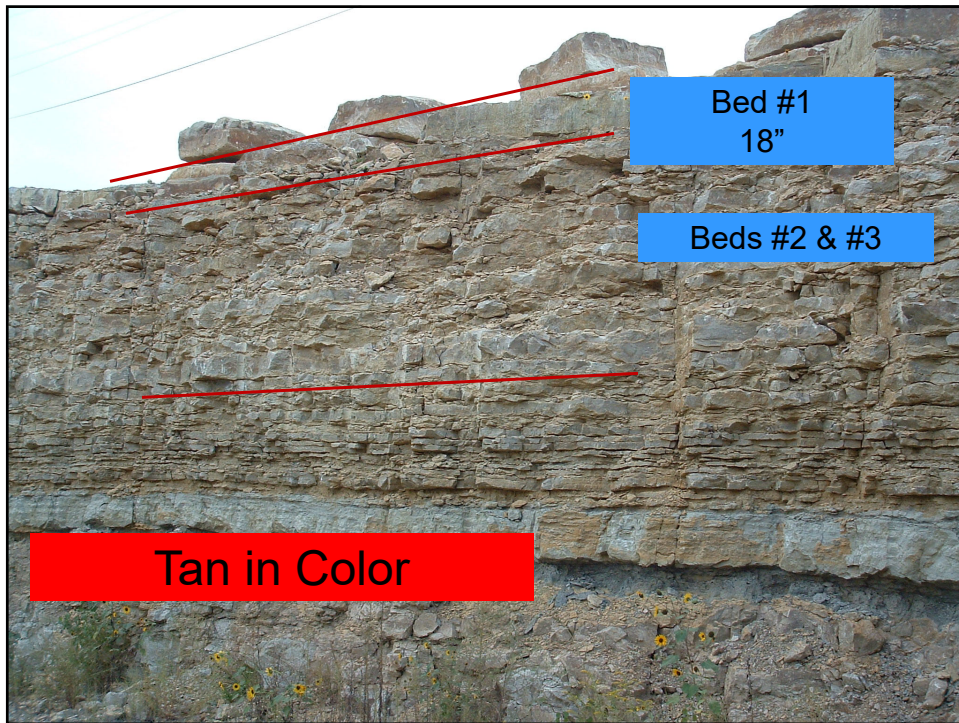

10



11



12

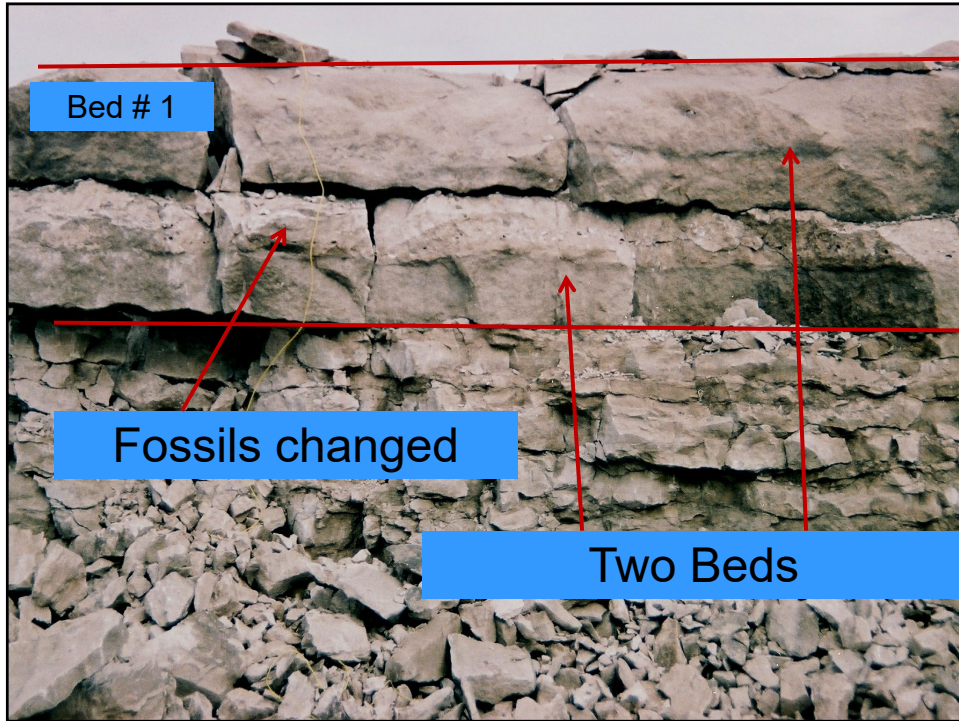

13

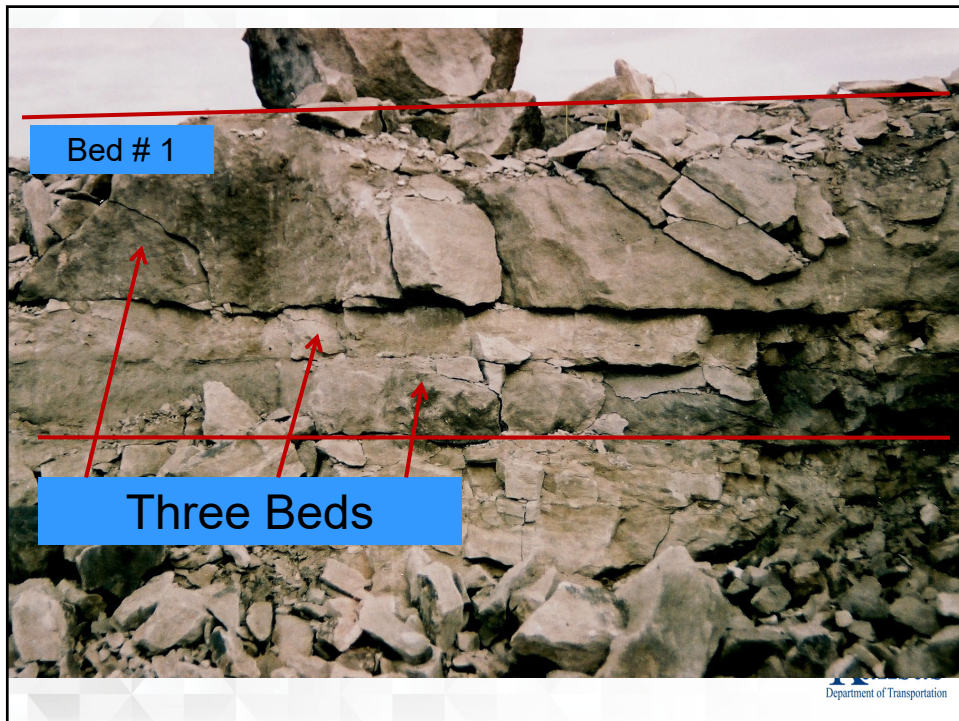

Department of Transportation

14

Upper Farley Ledge



15

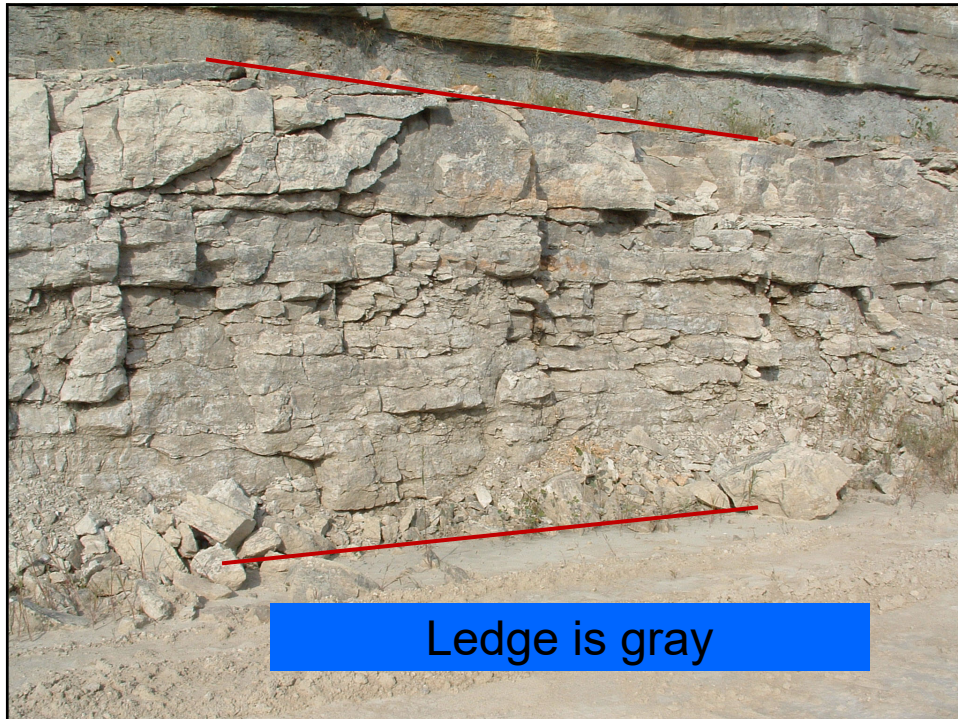

16



17



18

Upper Farley Ledge changes

	Specific Gravities						
	Dry	Sat	App	Abs	F&T	Wear	
1994	2.470		2.550		2.700	3.4 99 30	Total
1995	2.530		2.590		2.690	2.4 98 26	Total
1997	2.500		2.580		2.720	3.1 95 28	Scalped
1998	2.510		2.590		2.720	3.0 93 31	Scalped
1999	2.450		2.547		2.713	4.0 95 32	Scalped
2001	2.520		2.589		2.706	2.7 97 30	Scalped
2002	2.482		2.565		2.705	3.3 95 35	Total
2003	2.433		2.539		2.721	4.4 96 32	Total
2005	2.453		2.552		2.722	4.0 94 32	Total
2006	2.434		2.540		2.723	4.4 95 36	Total
2008	2.421		2.532		2.723	4.6 97 36	Scalped
2009	2.406		2.514		2.697	4.5 96 36	Scalped



19

SAFETY

When inspecting the ledge face always watch above you for loose rock or equipment working on top of ledge.

When inspecting from the top of a ledge be sure you are standing on safe ground.



20



21



22

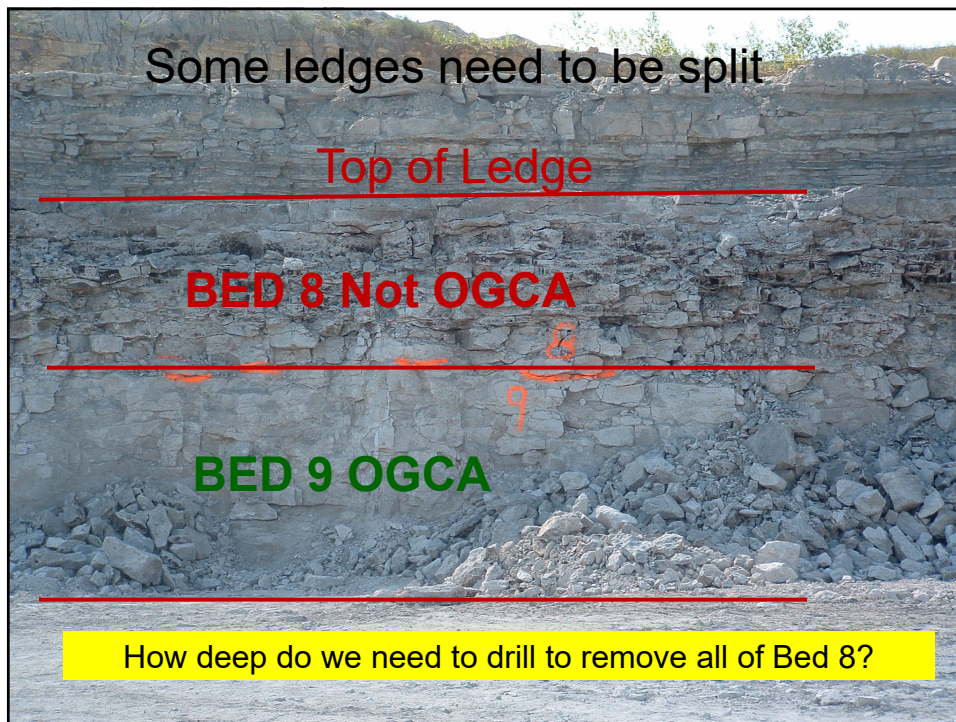

23

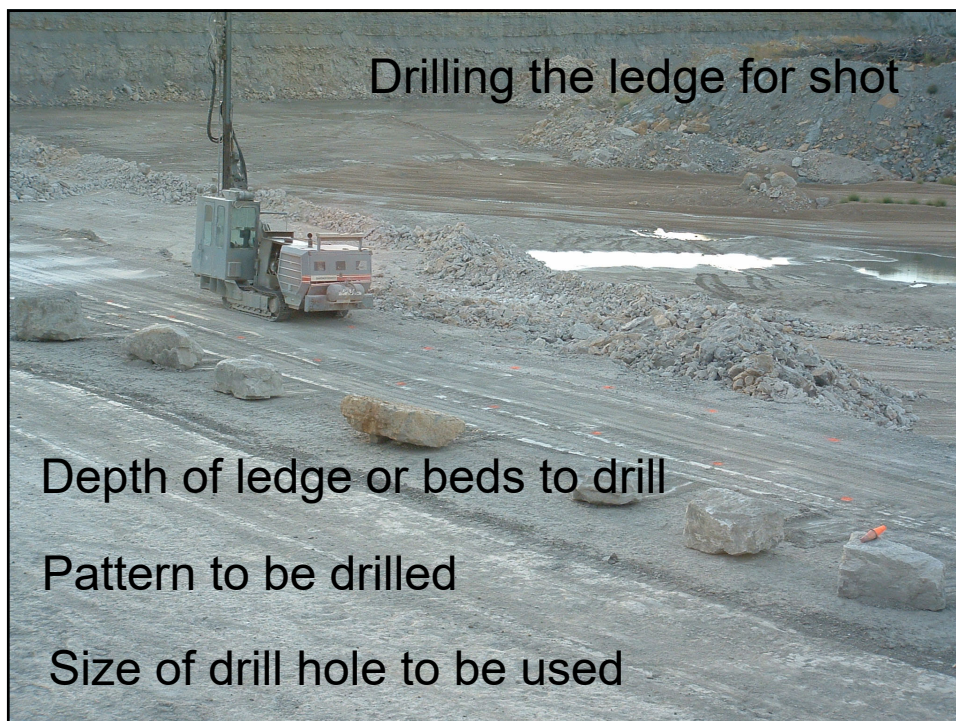

24

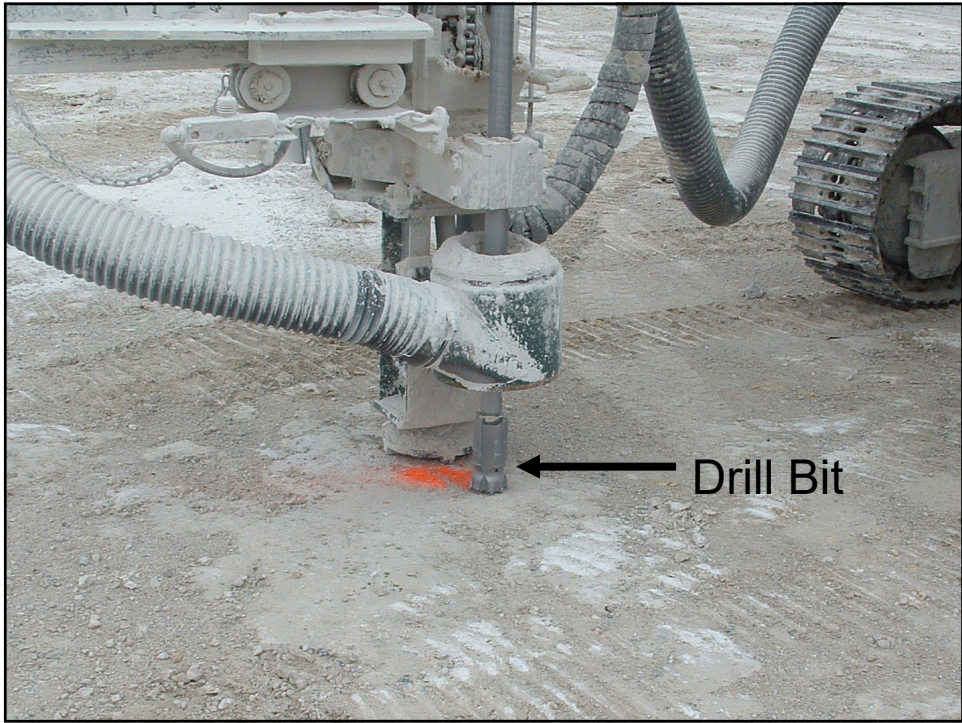

25

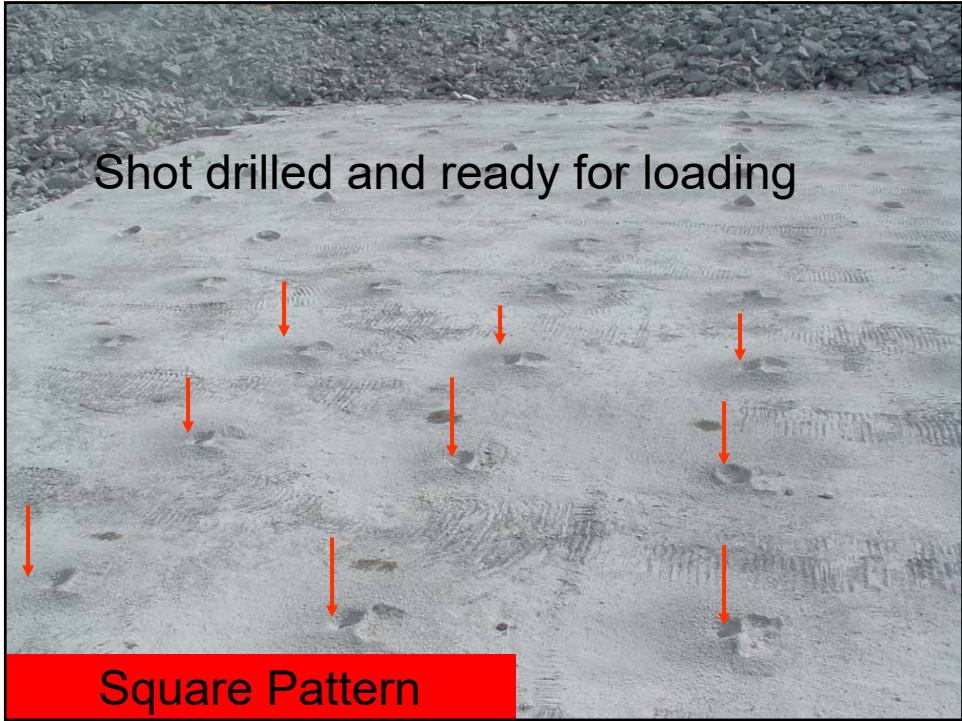

26

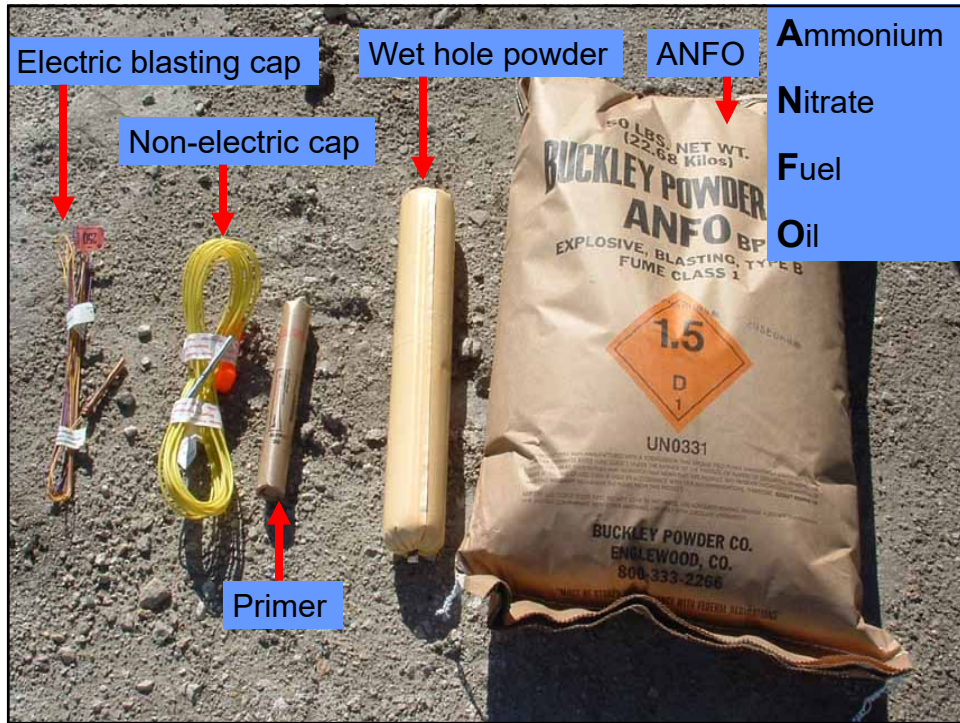

27

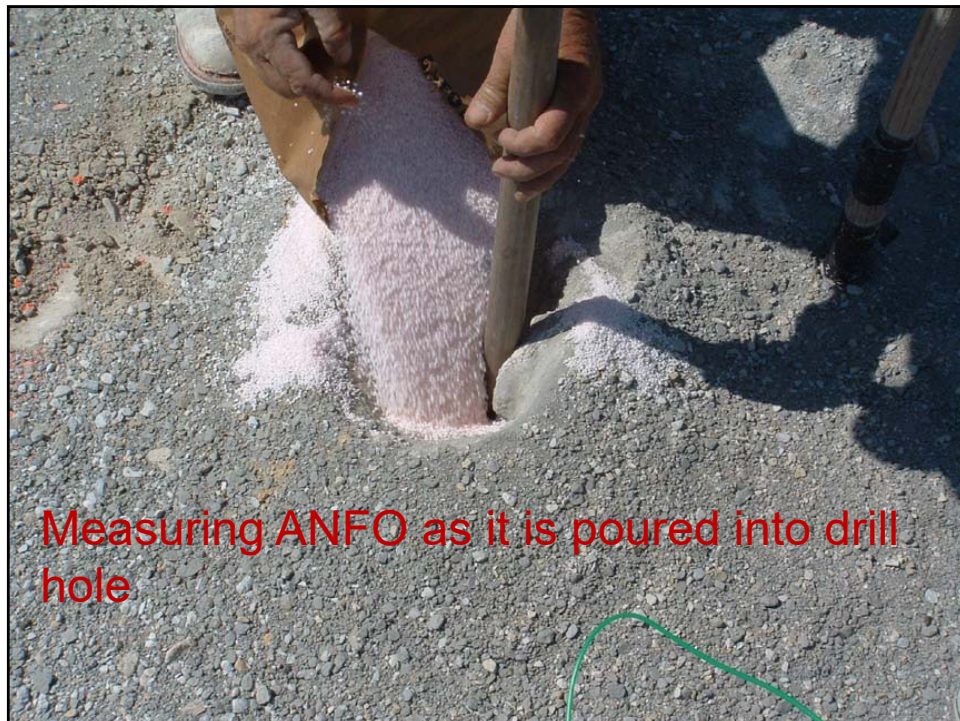

28

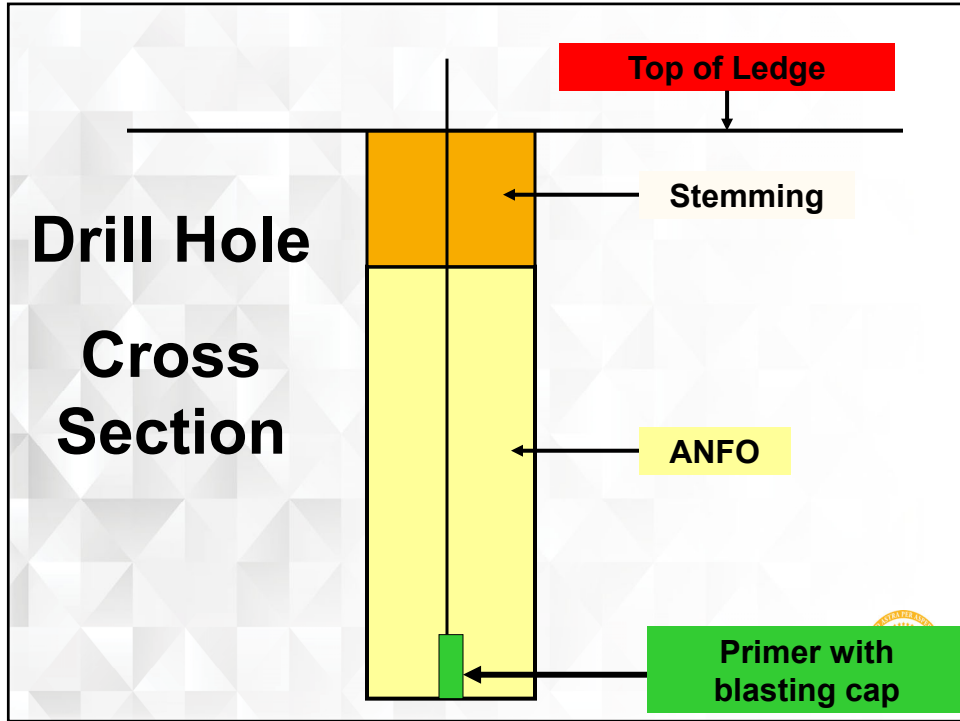

29



30

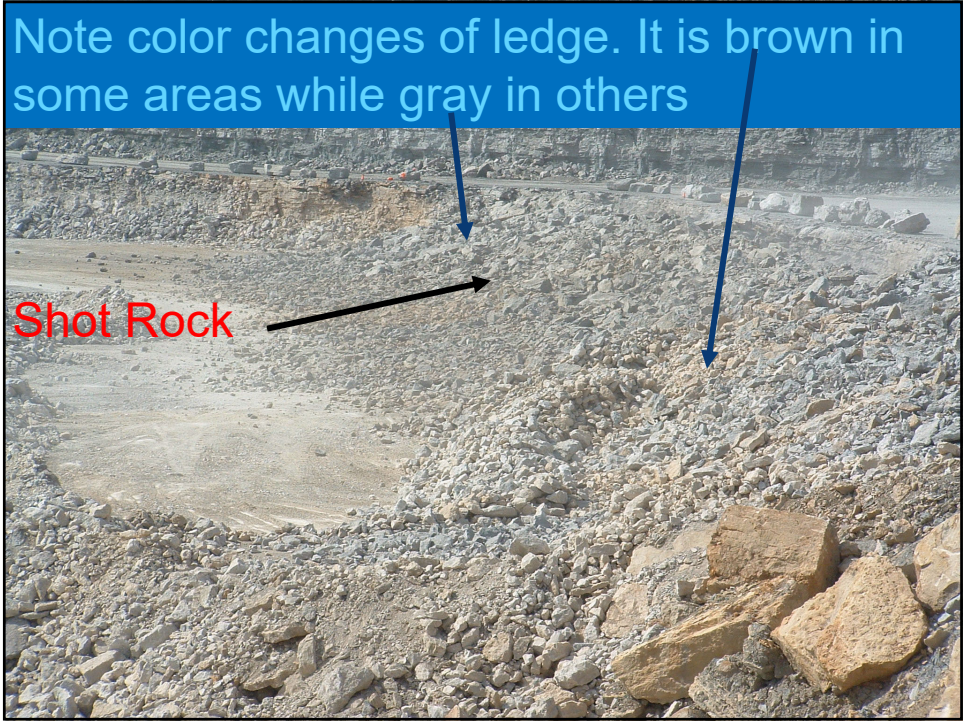

31

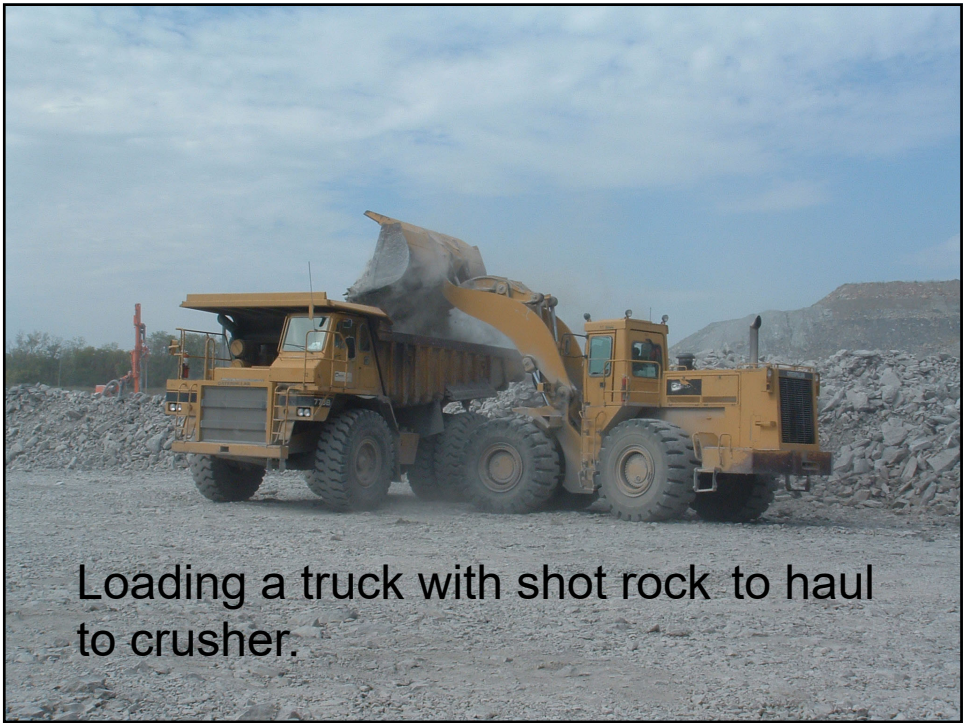

32



Shot rock dumped from truck into the feeder.

33



Shot rock being placed in feeder with loader.

34

Vibratory feeder with grizzly. Grizzly allows fines to bypass the crusher.



35



Vibratory feeder with two-step grizzly.

36

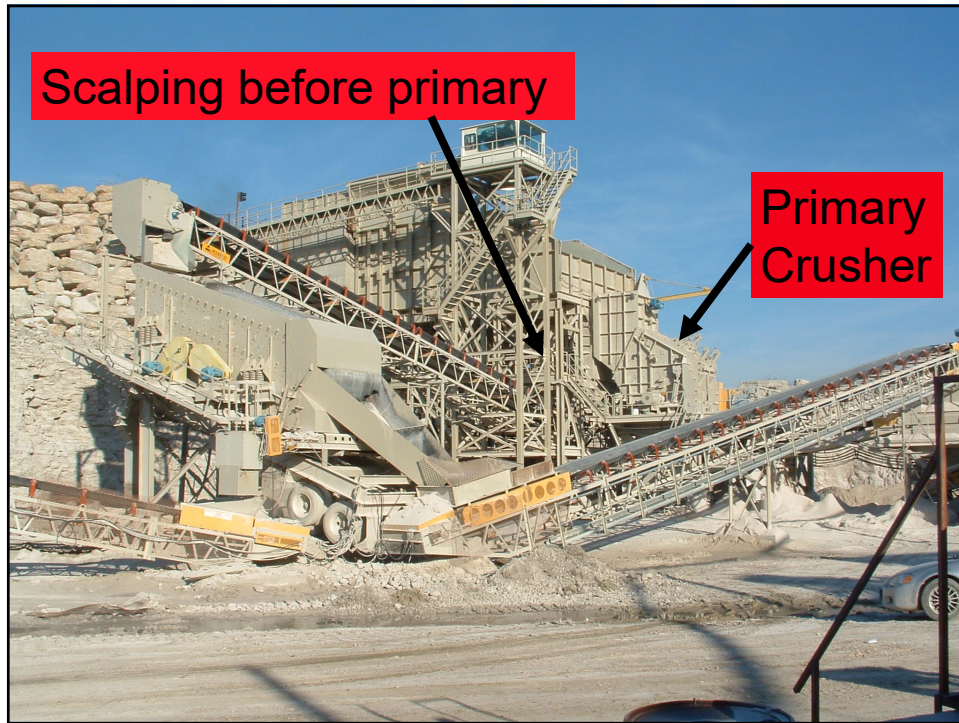

37

Primary Crushing

Two Types of Crushers:
Impact
Compression



38



Impact types:

**New Holland
Andreas**

Compression types:

**Jaw
Gyratory**

39

Impact Crushing some advantages:

- Greater reduction in size of shot rock
- More cubical shape (less elongated)
- Helps eliminate deleterious or poor quality particles

Compression Crushing some advantages:

- Produces less fines
- Less airborne dust
- Used with “hard” rock (less wear of metal parts)

40

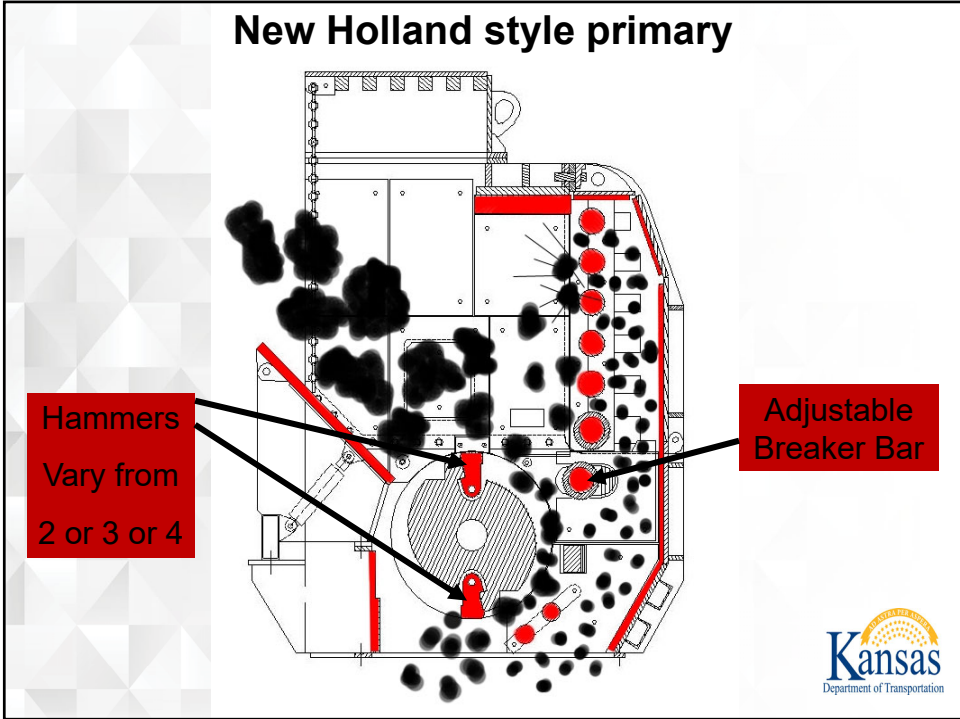

41



42

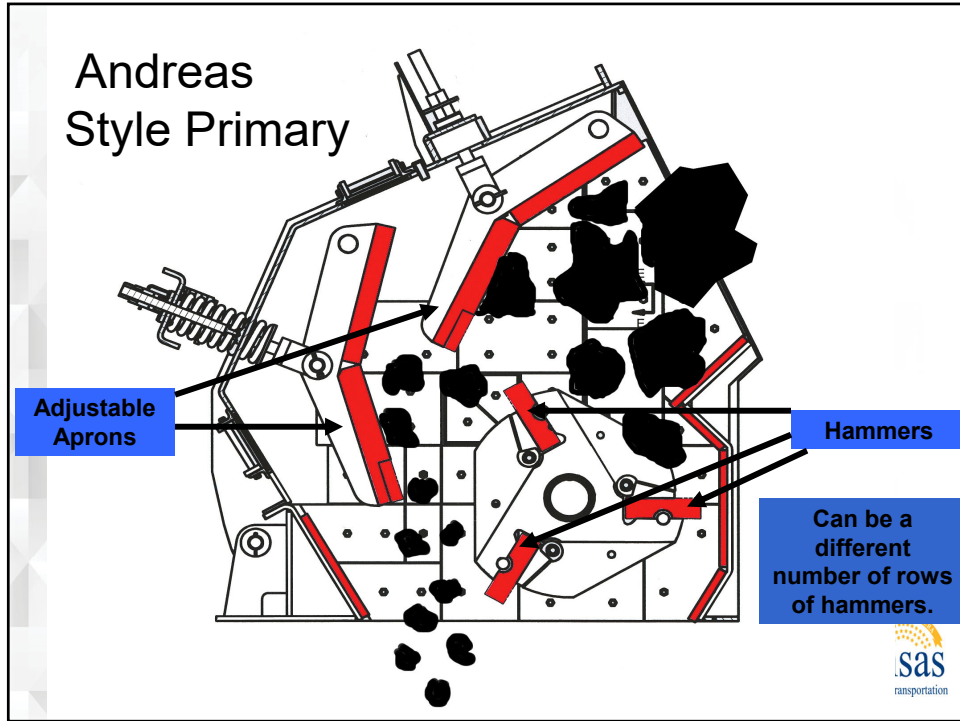

43



44



45

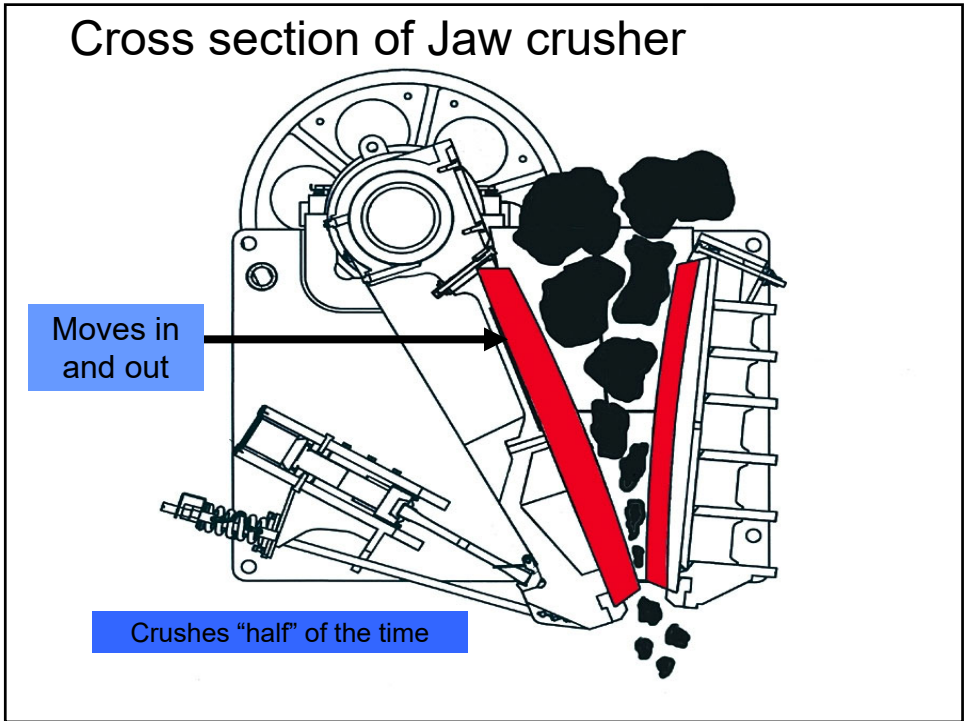

46

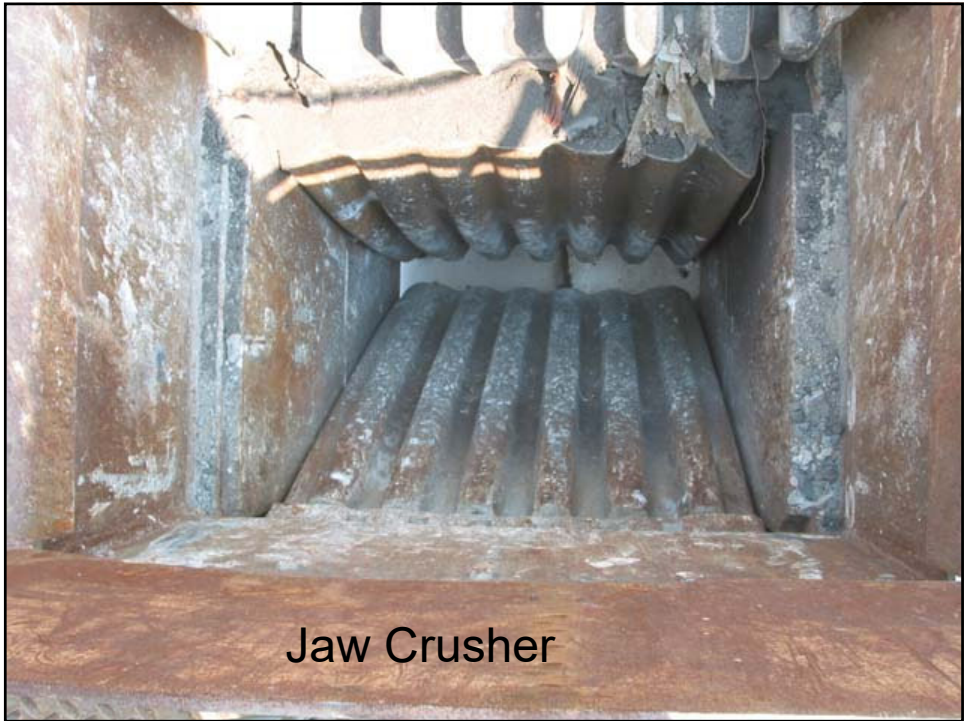

Jaw Crusher

47

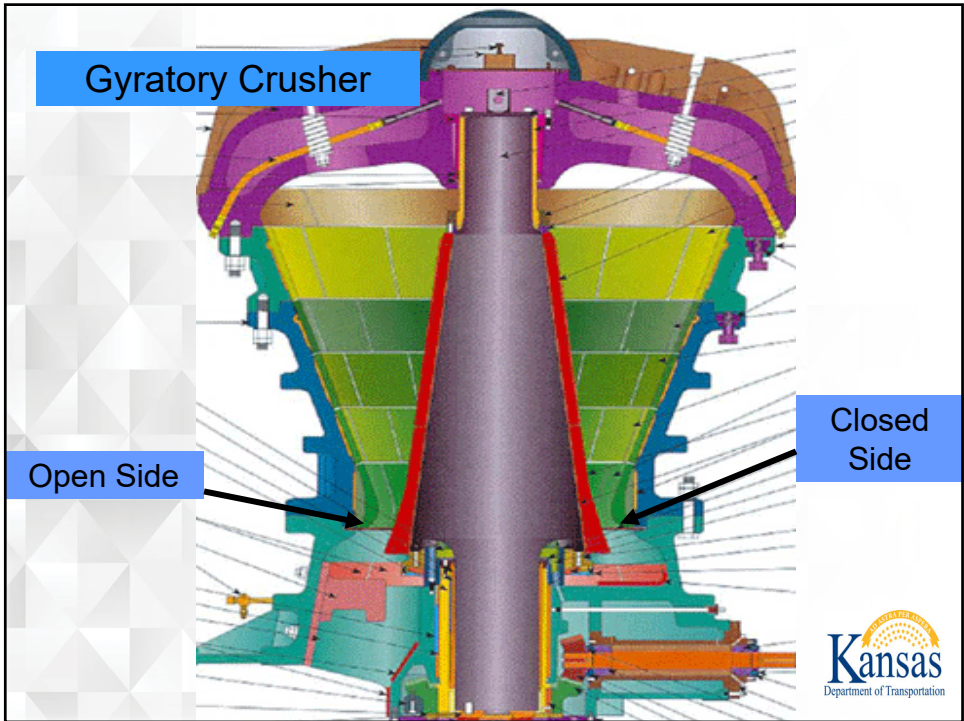

48

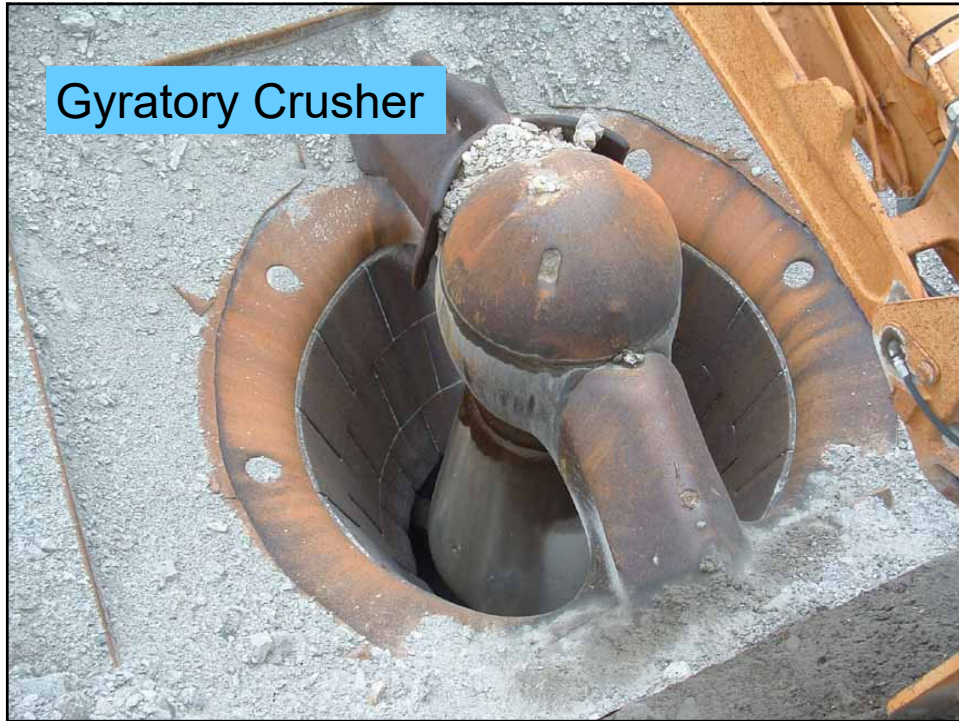

49

Surge Bins and Surge Piles

After the primary crushing some plants utilize a **surge bin** or **surge stockpile** to lessen the **variance** in the primary crushed rock.



50



51

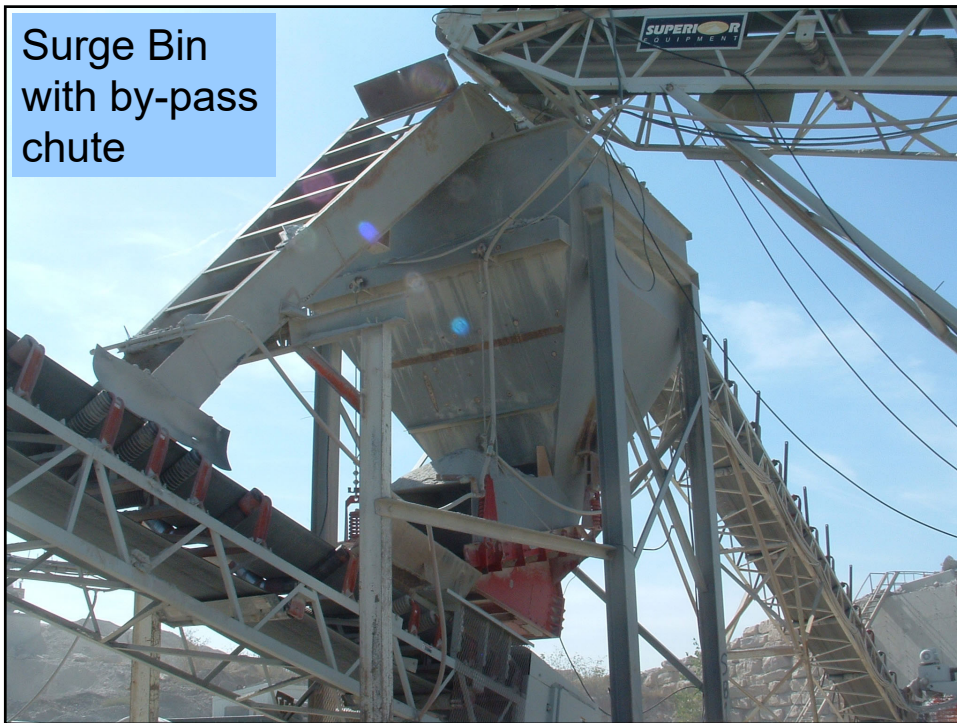

52



53



54

Screening Units

Screening Units separate the aggregates into various sizes



55

Screening Units

- Various sizes:
(4'x8', 5'x16', 8'x20'...)
- Various types:
(horizontal, inclined, high frequency...)
- Various number of decks: (single, double, triple ...)



56

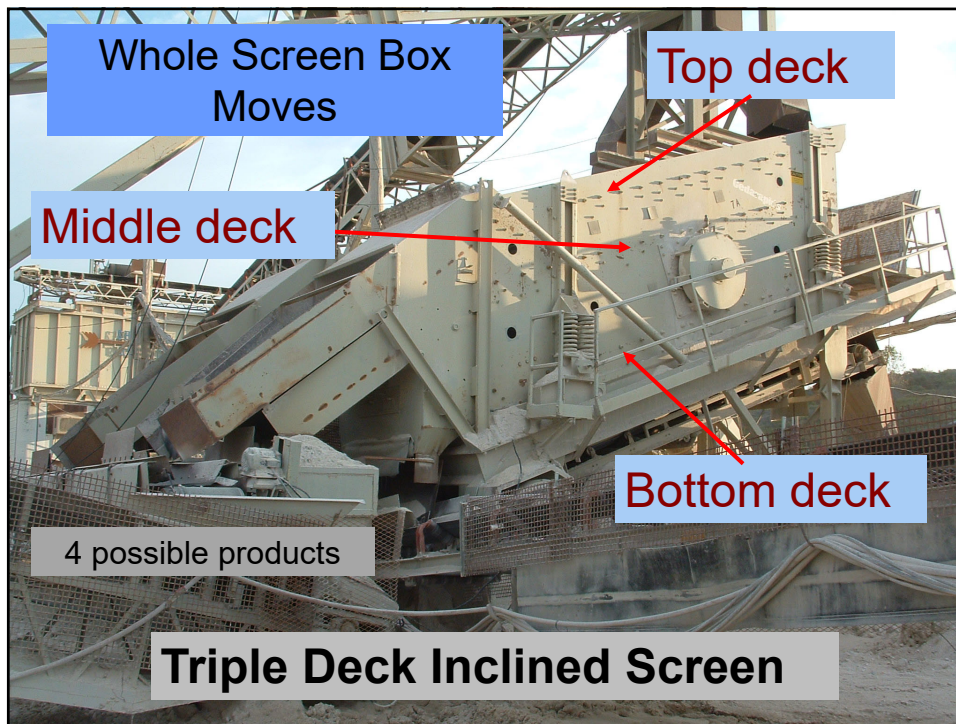

57

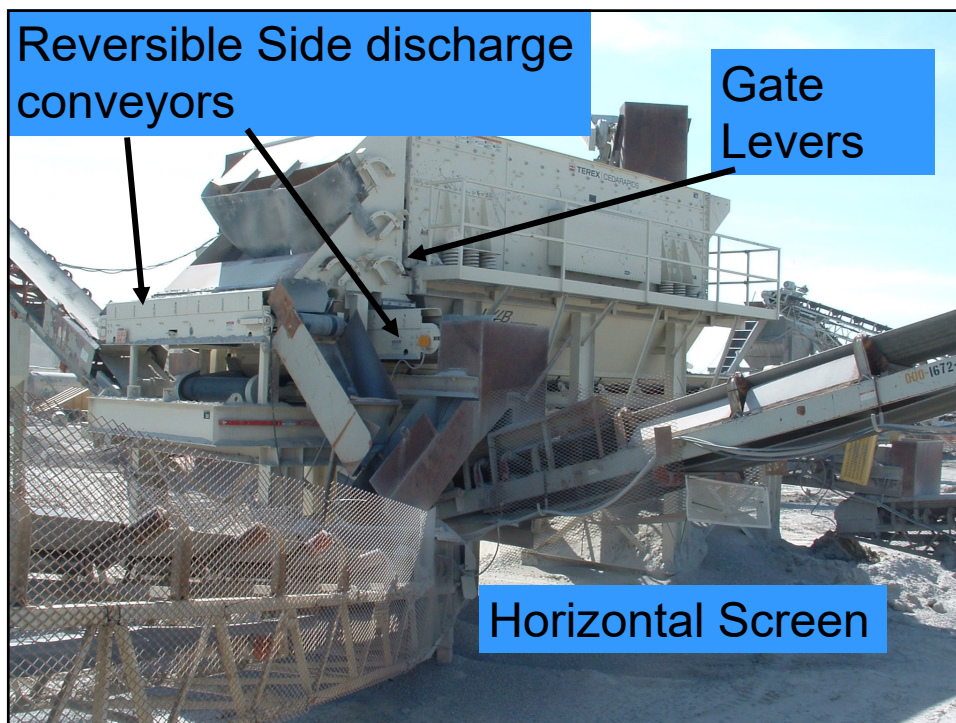

58

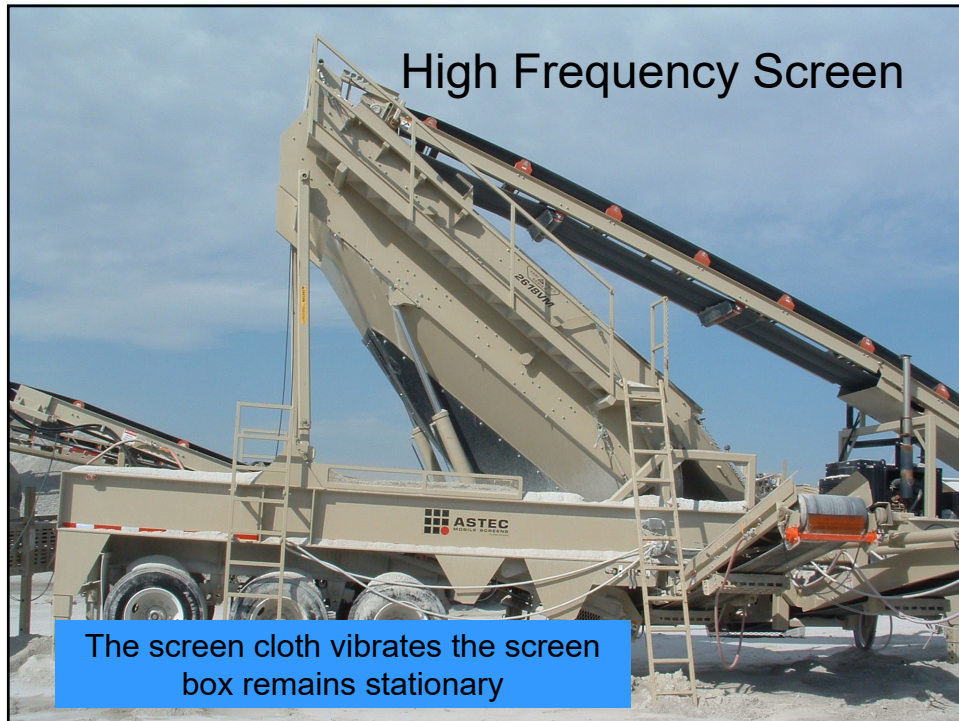

59

Screen Cloth

Using different types of screen cloth on the screen unit can change the product gradation and the shape of the particles



60

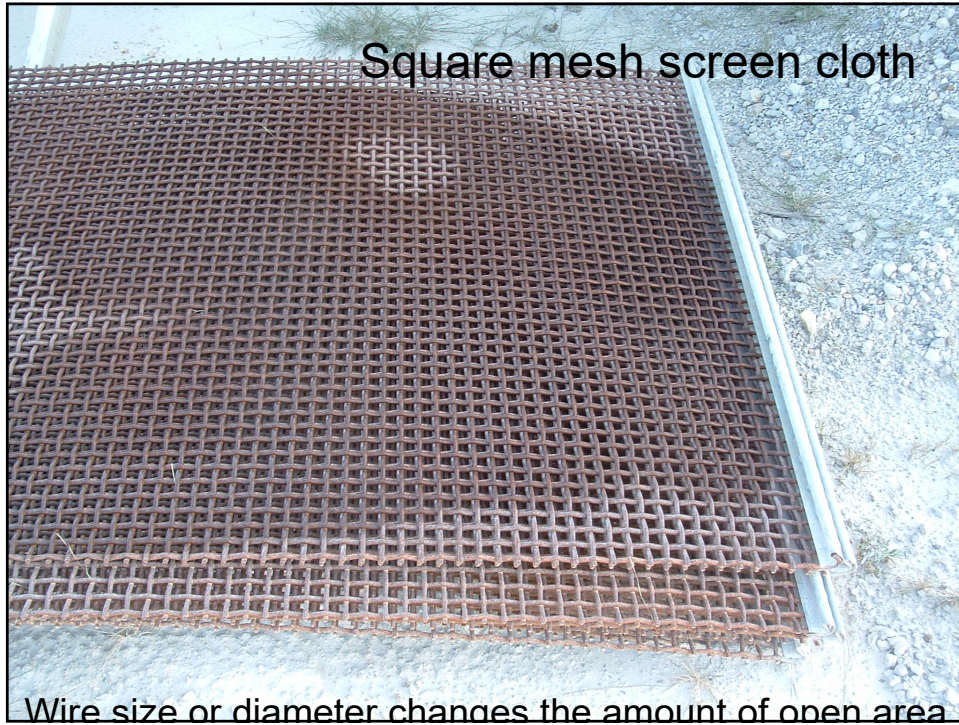

61

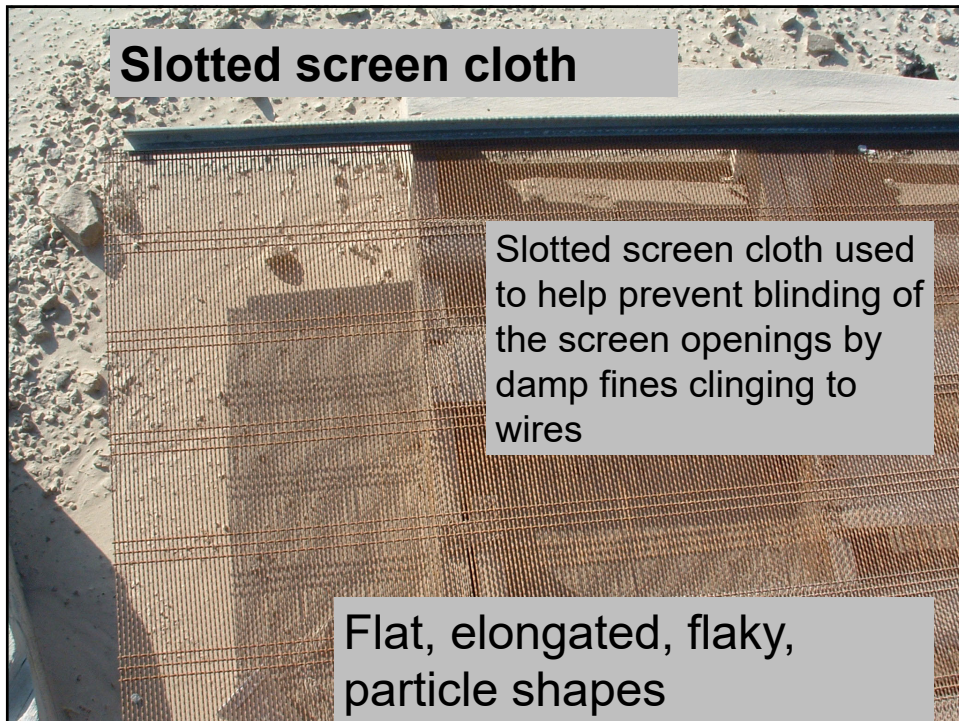

62

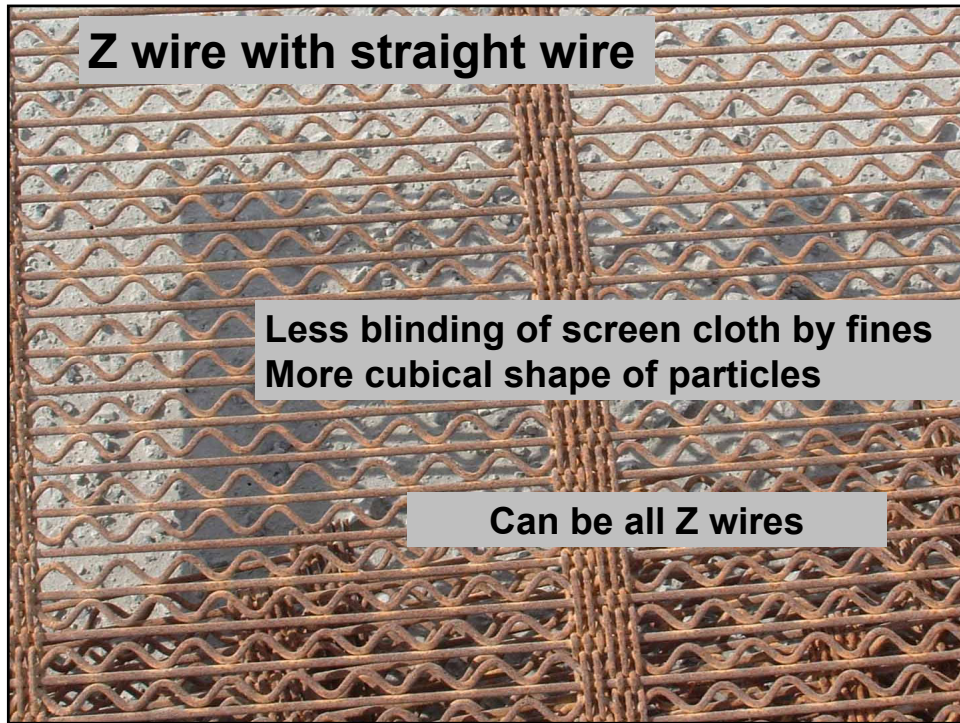

63

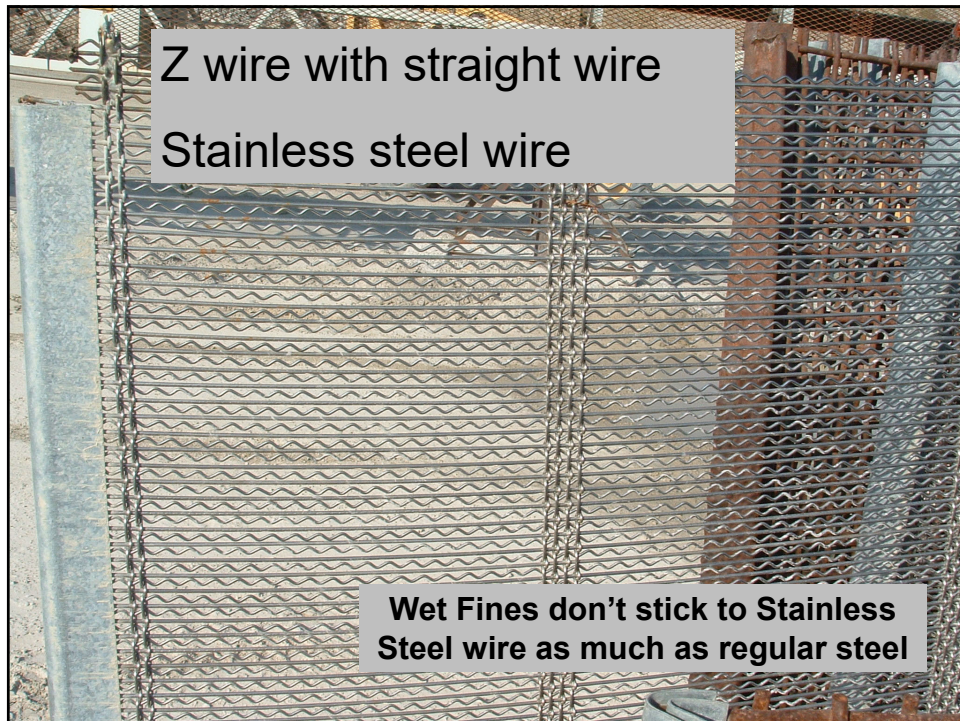

64



65

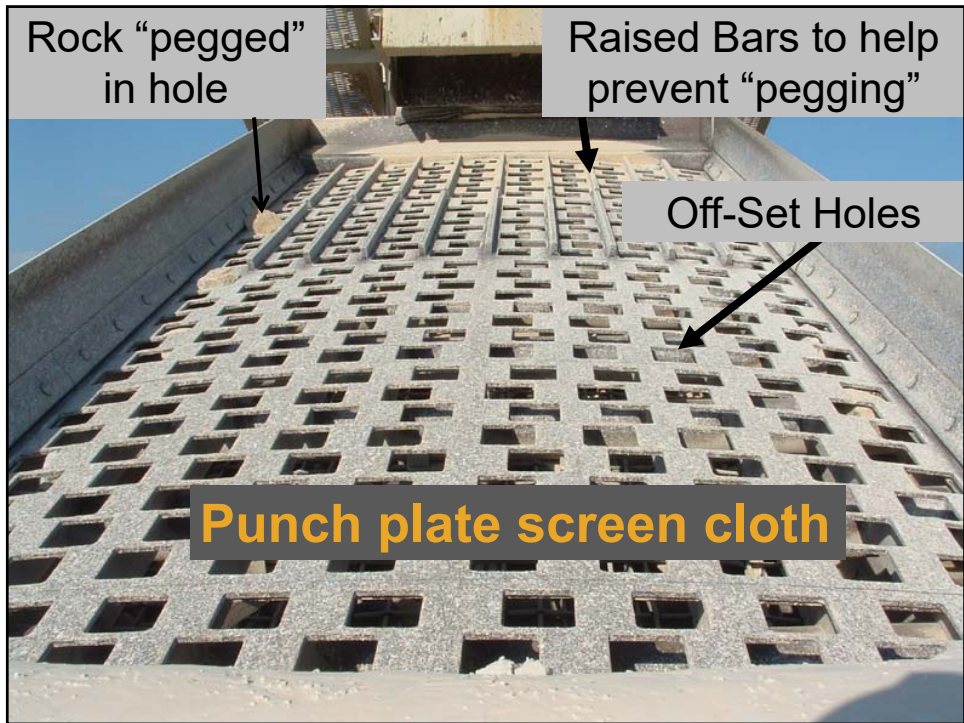

66



67

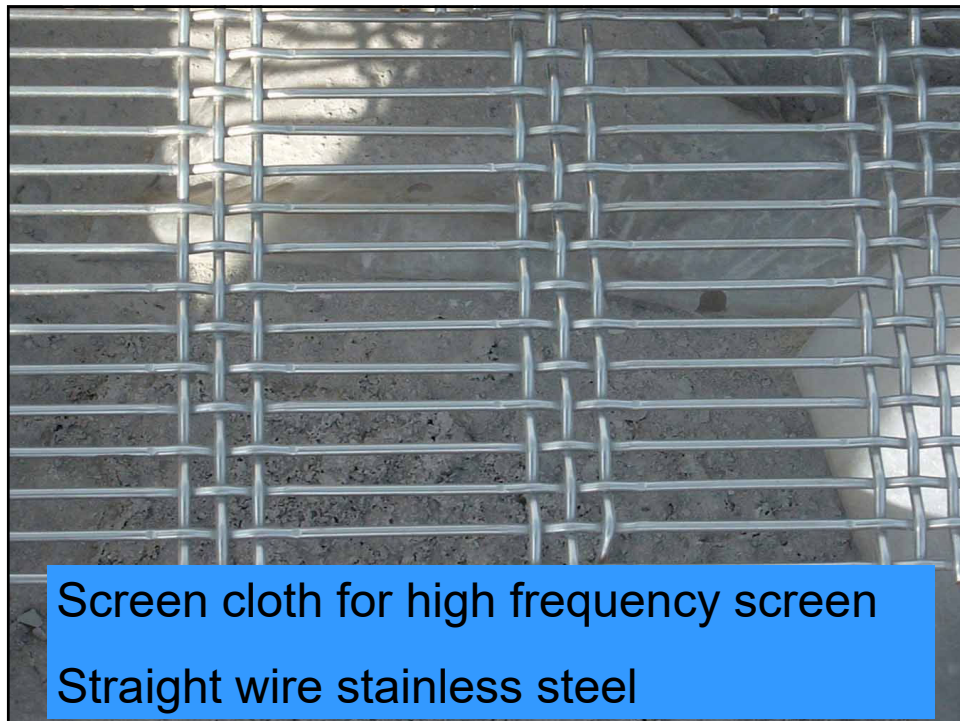

68

Screen cloth can be made of materials other than metal:

Rubber

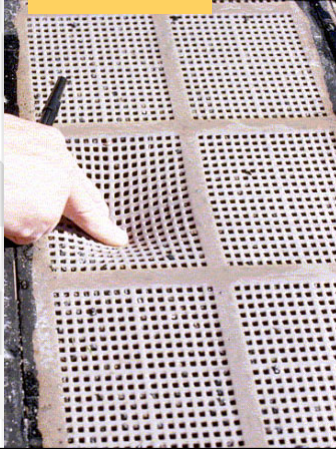

Polyurethane



69

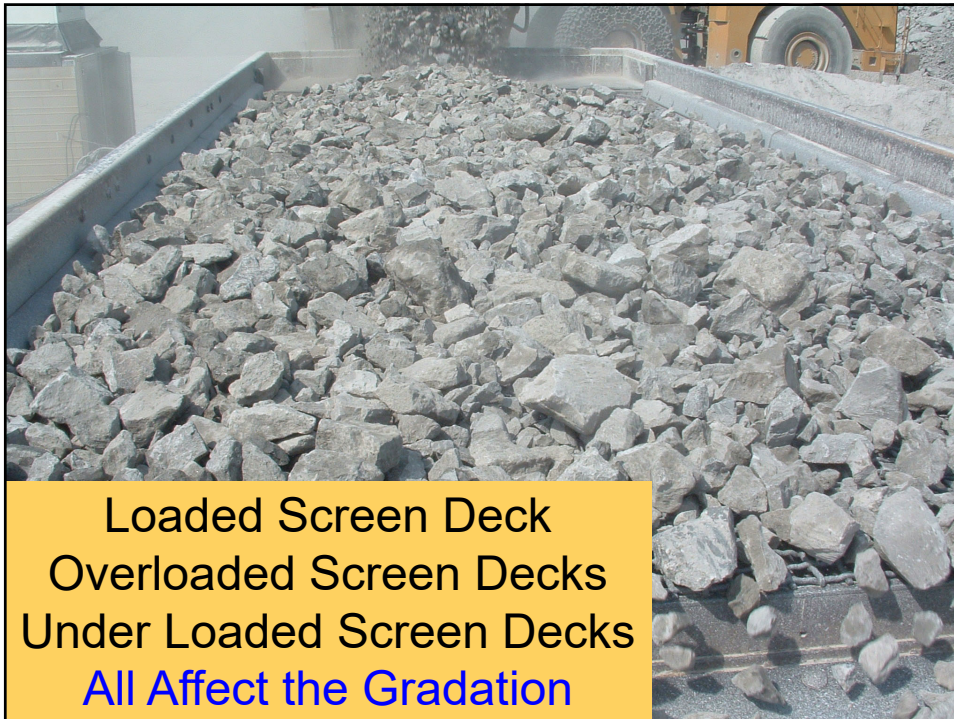

Loaded Screen Deck
Overloaded Screen Decks
Under Loaded Screen Decks
All Affect the Gradation

70

Secondary and Tertiary crushing

Impact crushers

Vertical Shaft

Horizontal Shaft

Compression crushers

Cone

Rolls

71

Secondary impact crushers

- More fines but better cubical particle shape
- Handle larger feed size aggregate
- Reduces deleterious

Secondary compression crushers

- Less fines production
- More flat and elongated pieces
- Control feed size and “choke fed”

72

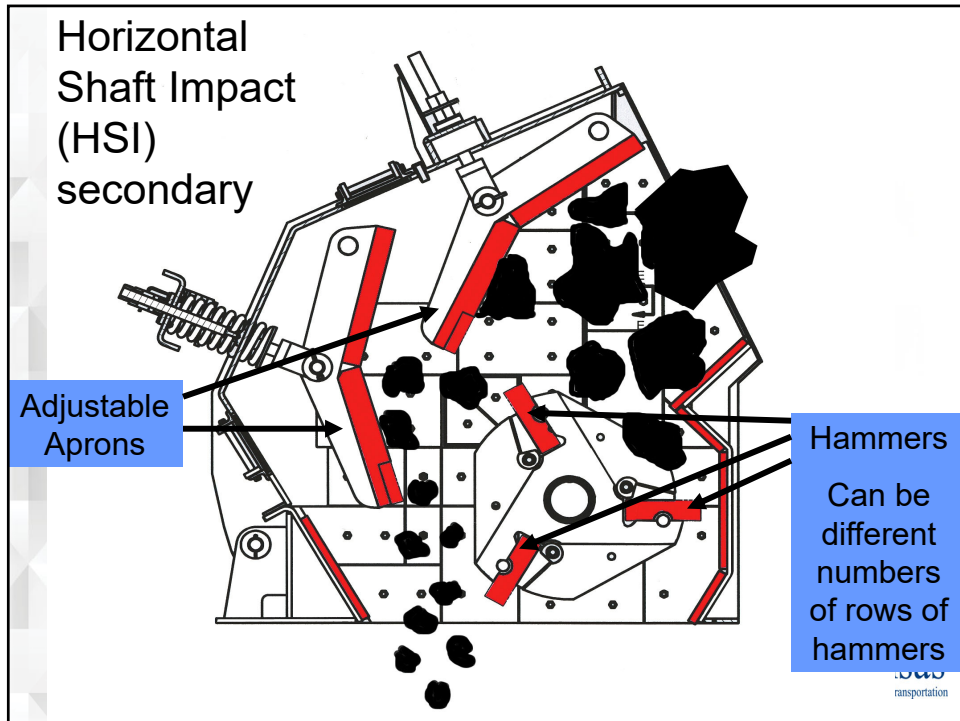

73



74



75

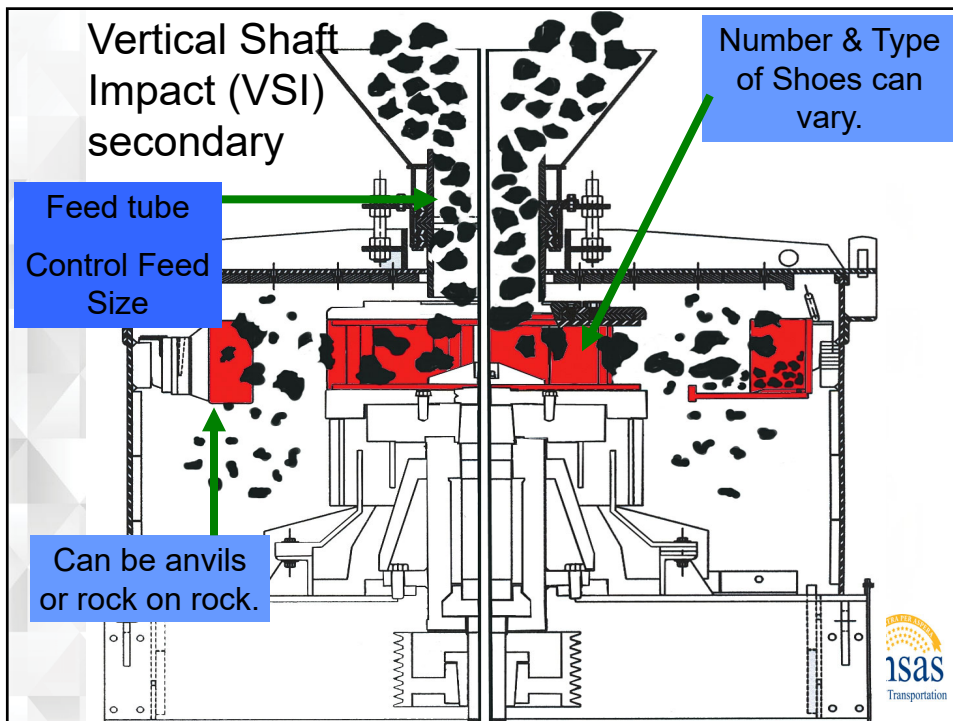

76

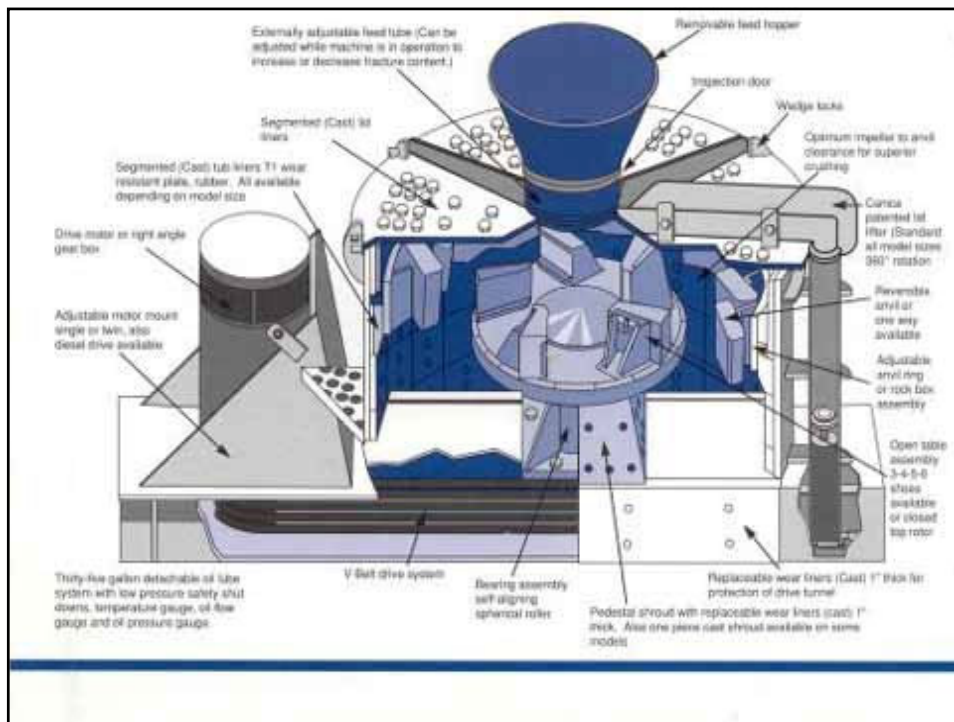

77

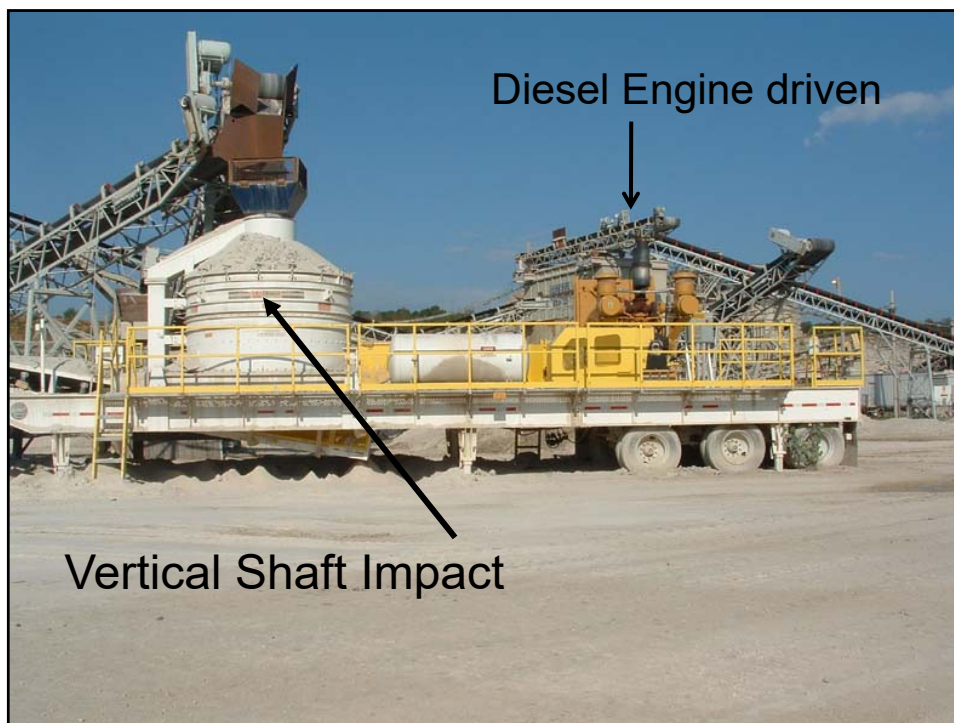

78

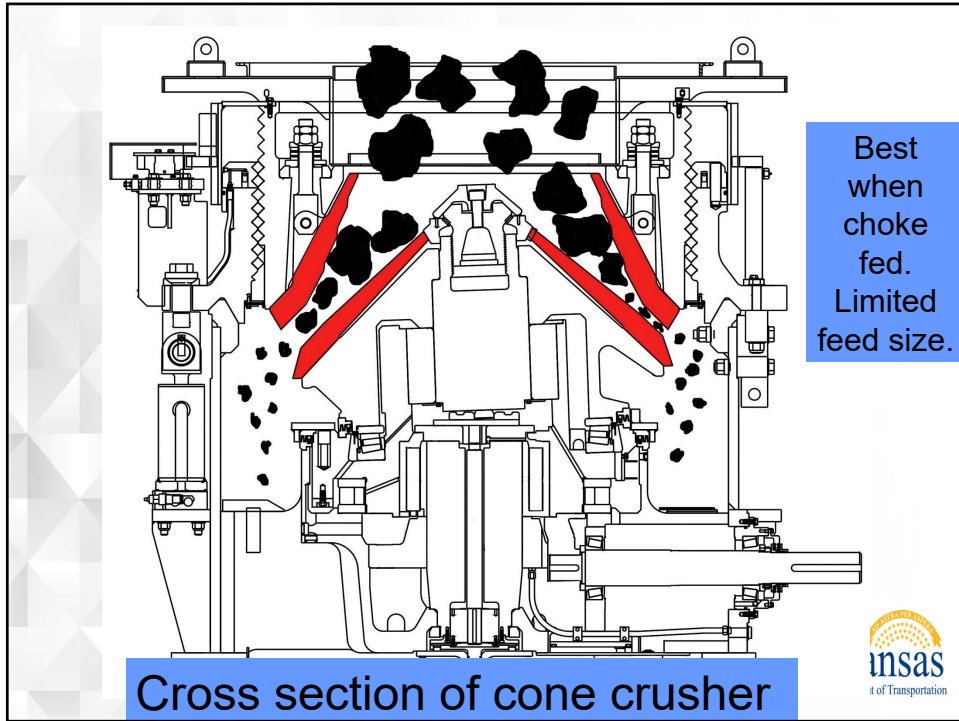

79

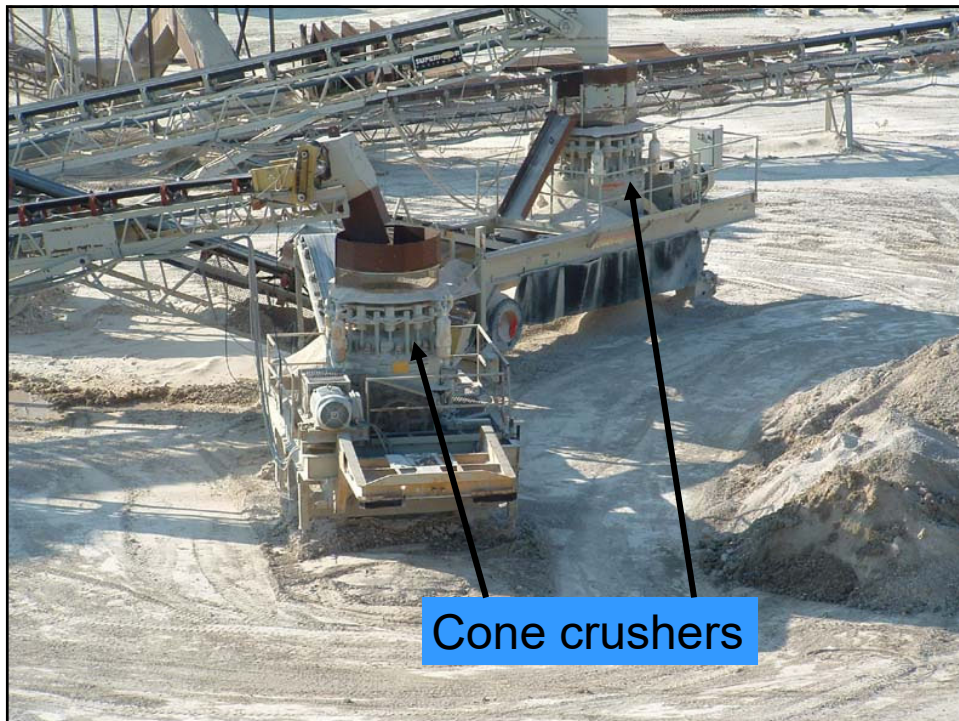

80

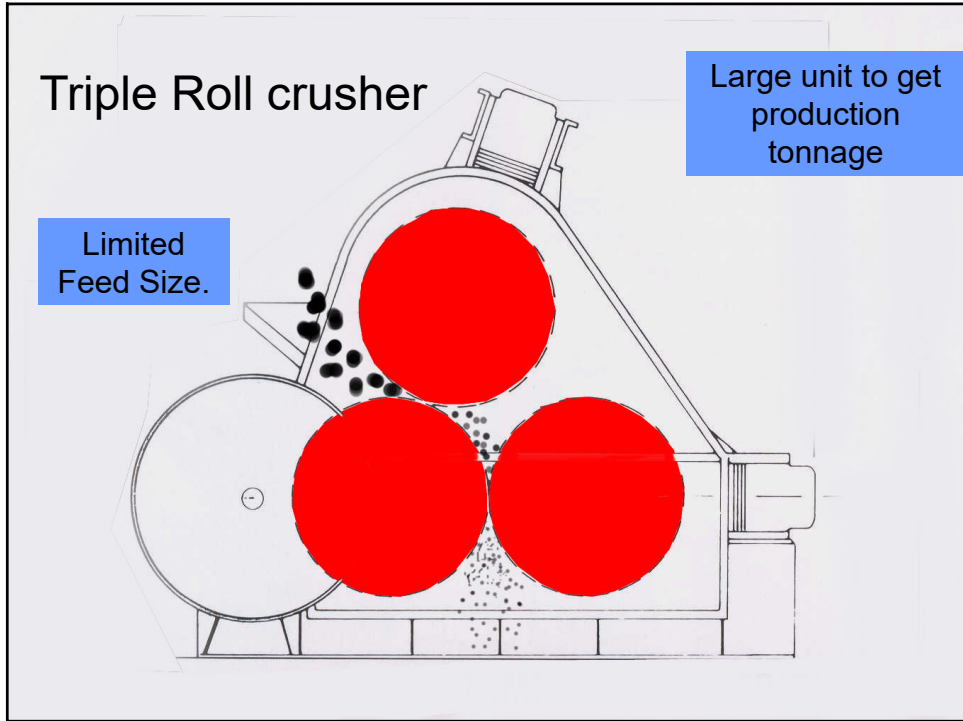

81

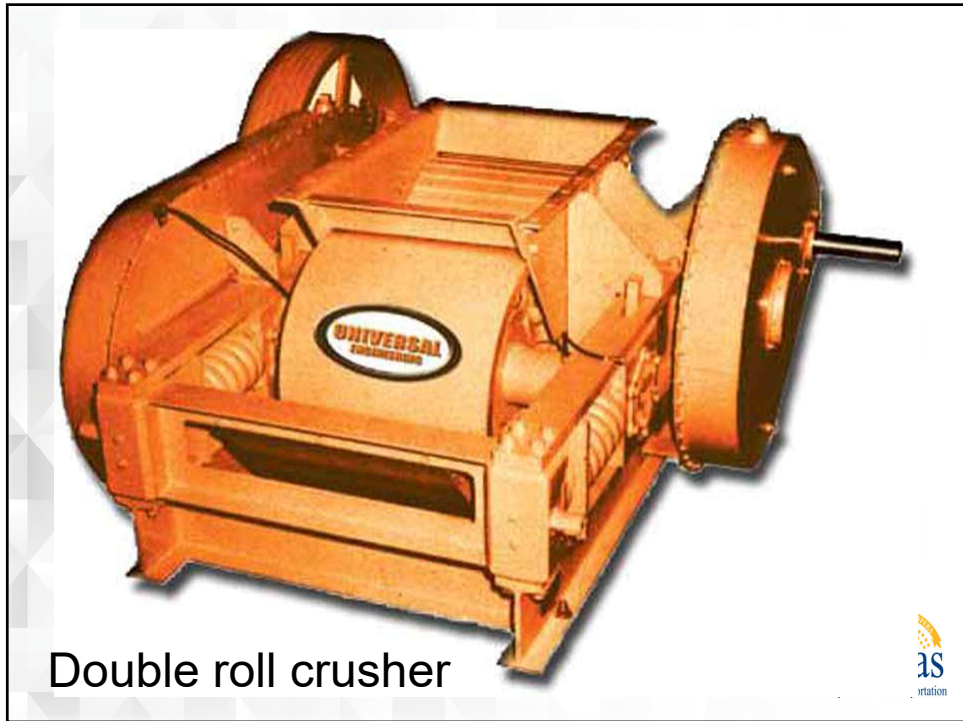

82

Stockpiling

- Product placed in bins and hauled to stockpile
- Product stacked using stacking conveyors



83



84



Stockpile built in lifts

85

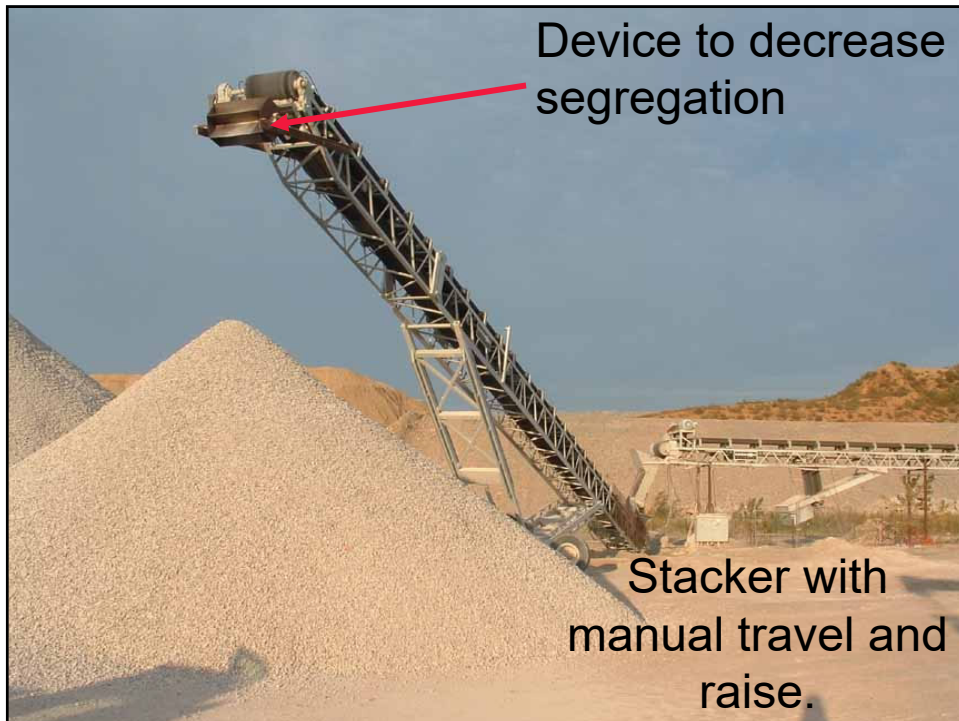

Device to decrease segregation

Stacker with manual travel and raise.

86

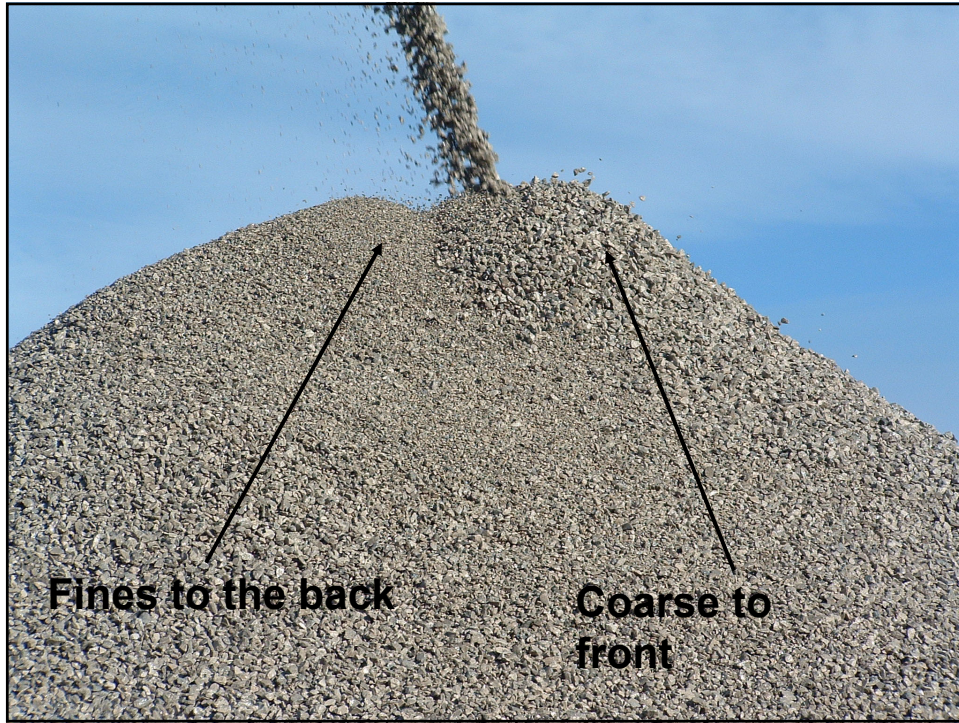

87

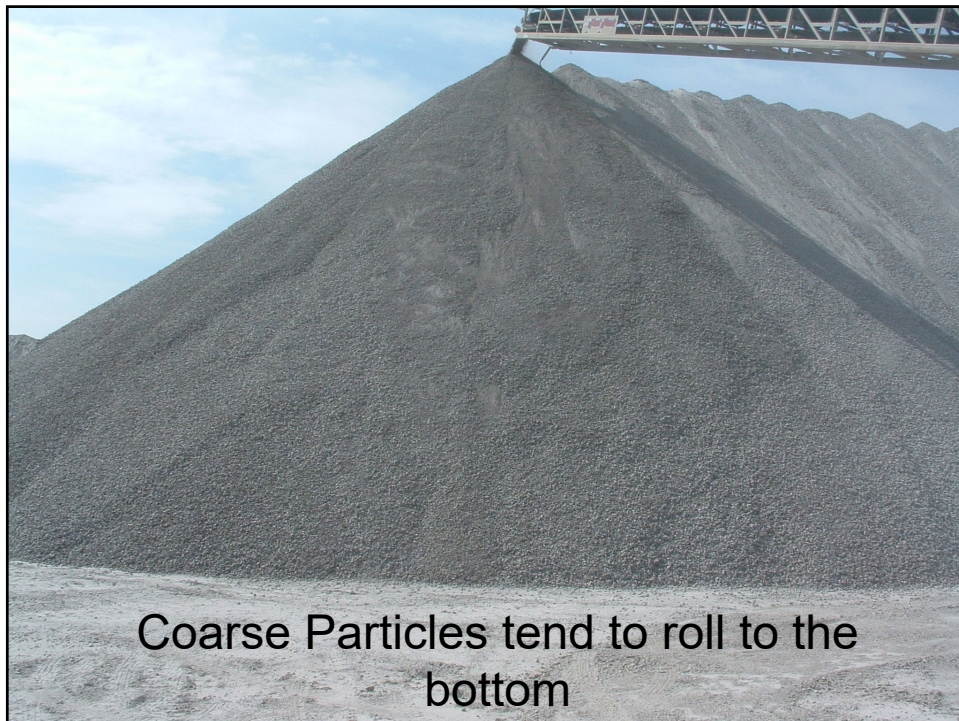

88



89

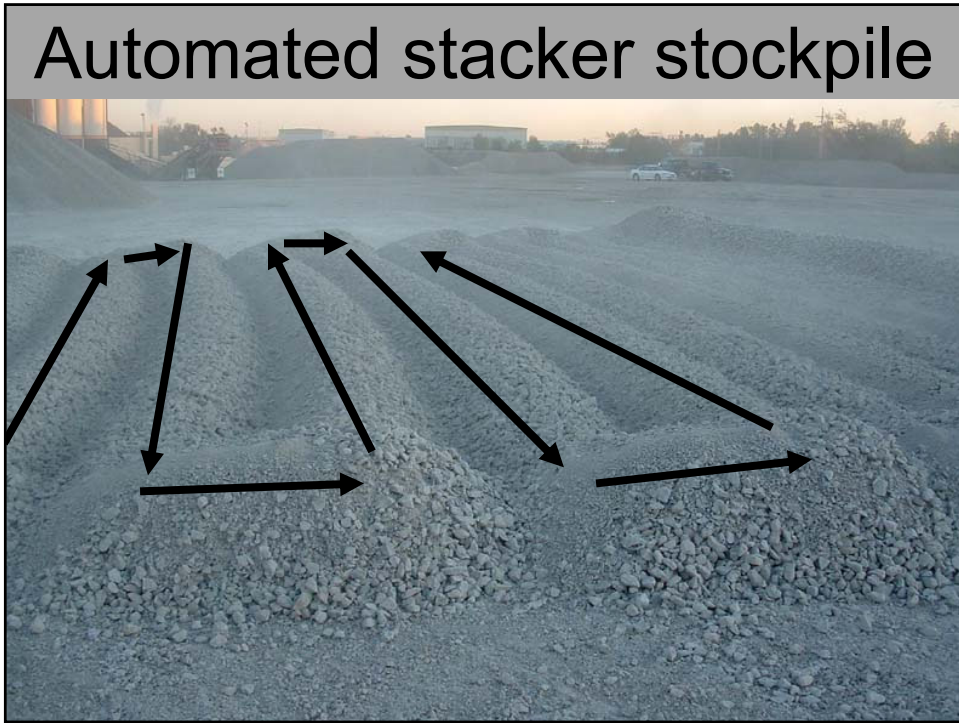

90

Two Crushing Plants What's the difference?

Plant #5



Plant #1



91

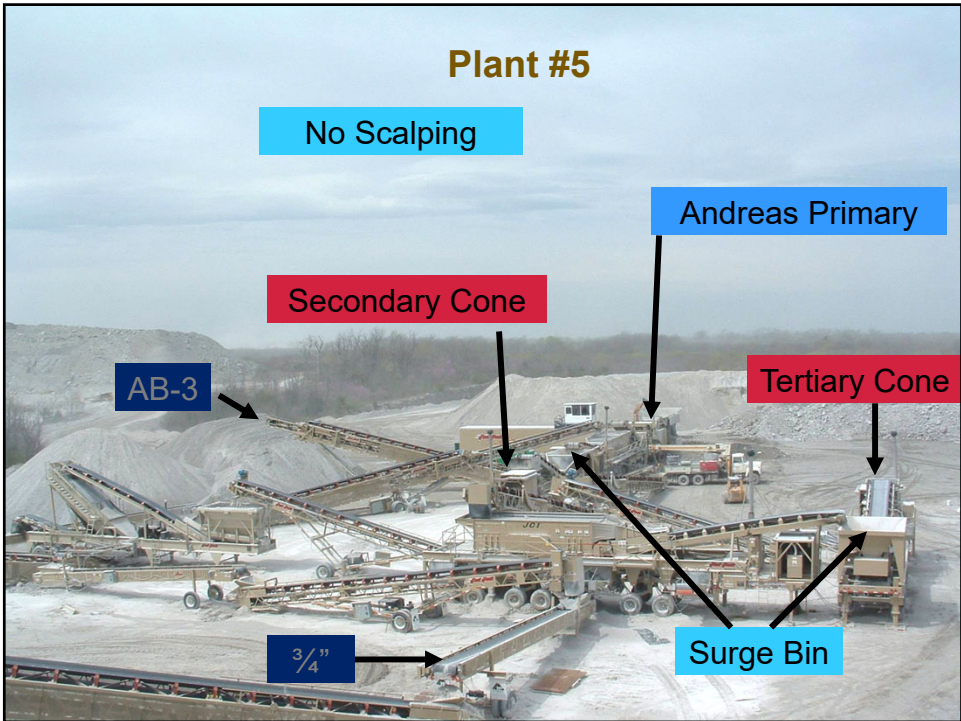

92

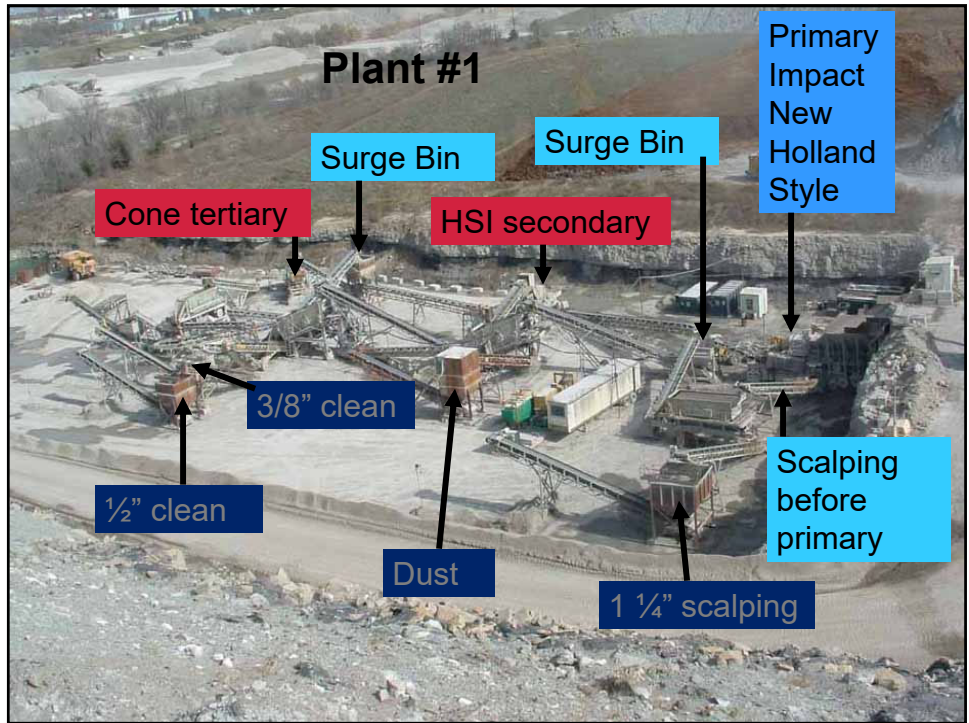

93

Does Scalping help?

KDOT Official Quality Results

Stoner Ledge	Scalping	Rest of Plant
Sp. Gr. Dry	2.513	2.574
Sp. Gr. Sat	2.587	2.624
Sp. Gr. App	2.713	2.711
Absorption	2.9	2.0
L.A. Wear	39	29
F & T Soundness	0.89	0.98



94

KDOT Official Quality Results			
Farley	Scalping	Rest	Total
Ledge	2005	2005	2007
Sp. Gr. Dry	2.609	2.620	2.608
Sp. Gr. Sat	2.650	2.656	2.651
Sp. Gr. App	2.720	2.717	2.724
Absorption	1.6	1.4	1.6
L.A. Wear	29	30	25
F & T	0.95	0.96	0.97



95

Specific Gravity Results			
Farley	Plant #1	Plant #1	Plant #5
Ledge	-3/4"	-1/2"	-1"
Sp. Gr. Dry	2.602	2.610	2.613
Sp. Gr. Sat	2.646	2.651	2.652
Sp. Gr. App	2.720	2.719	2.720
Absorption	1.663	1.534	1.499



96

A Ledge is a Ledge!

or

Just because it has the same name does it mean it's the same quality



97

Argentine Ledge Attributes

Bonner Springs		Olathe	Shawnee
Ledge Depth 36'		Ledge Depth 20'	Ledge Depth 24'
10' to 36' Class 1		Top 5' Class 1	Top 14' Class 1
Upper 18' Lower 18'			
2.400	2.308	2.563	2.546
2.499	2.434	2.622	2.603
2.664	2.642	2.723	2.701
4.1	5.5	2.3	2.3
F&T 0.97	F&T 0.98	F&T 0.92	F&T 0.97
Wear 38	Wear 40	Wear 32	Wear 29



98

Getting ready for a quality??!!

Things for a producer to think about.....

Depth of ledge:

Full depth or splitting ledge?

Scalping or total production?

Do we get a quality on the scalpings?

How many crushing processes?

How many qualities?

Washed product?

Should it have a quality by itself?

What products to make?

What will be the top size of products?



99

KTMR-21 SOUNDNESS & MODIFIED SOUNDNESS OF AGGREGATES BY FREEZING AND THAWING

d.2. Official Quality Aggregate (Soundness)

d.2.b. Final preparation shall consist of bringing the sample to a surface dry condition at room temperature, screened over 25.0, 19.0, 9.5, 4.75, 2.36 mm (1 in, 3/4 in, 3/8 in, No. 4, and No. 8) sieves and a 5,000 gram test sample selected to meet one of the gradings below that is most representative of the "as received" sample.

Grading Designation	Cumulative Mass Retained (grams)				
	Individual Square Mesh Sieves				
	(1 in)	(3/4 in)	(3/8 in)	(No. 4)	(No. 8)
I	0	2250	1750	500	500
II	...	0	3500	1000	500
III	0	4000	1000



100

**AASHTO T-96 RESISTANCE TO DEGRADATION OF SMALL-SIZE AGGREGATE BY
ABRASION AND IMPACT IN THE LOS ANGELES MACHINE
Grading B**

**Passing $\frac{3}{4}$ " Retained on $\frac{1}{2}$ "
Passing $\frac{1}{2}$ " Retained on $\frac{3}{8}$ "**



101



**When sampling for quality be sure to take it over a period of
time to ensure that all portions of the ledge are included in
the quality.**

102

How many tons are in that stockpile? Using a Drone or a UAV



103

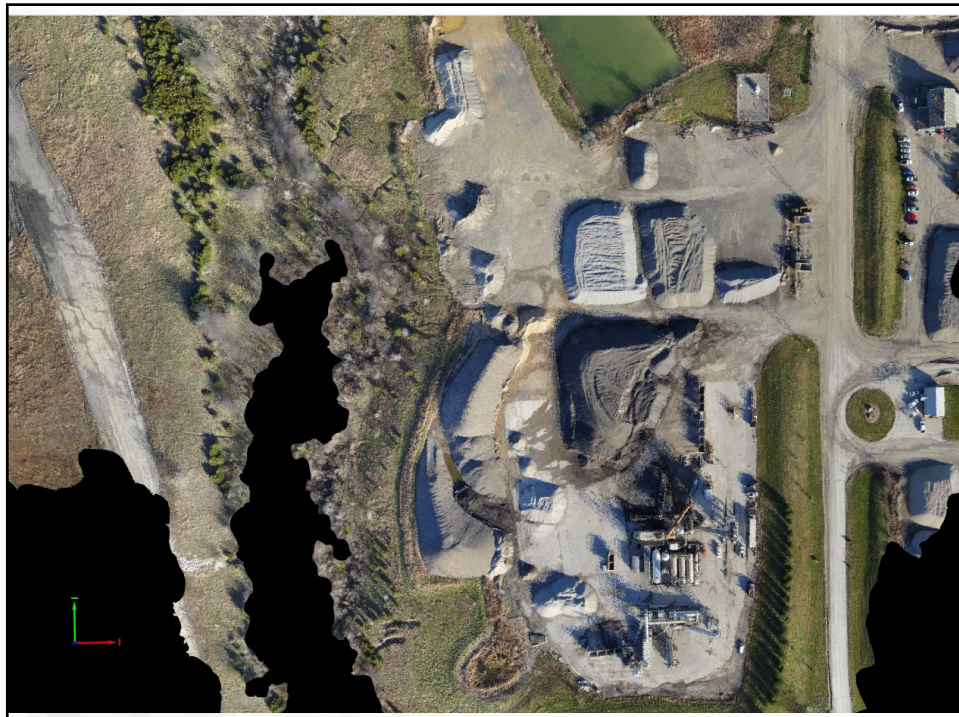

104

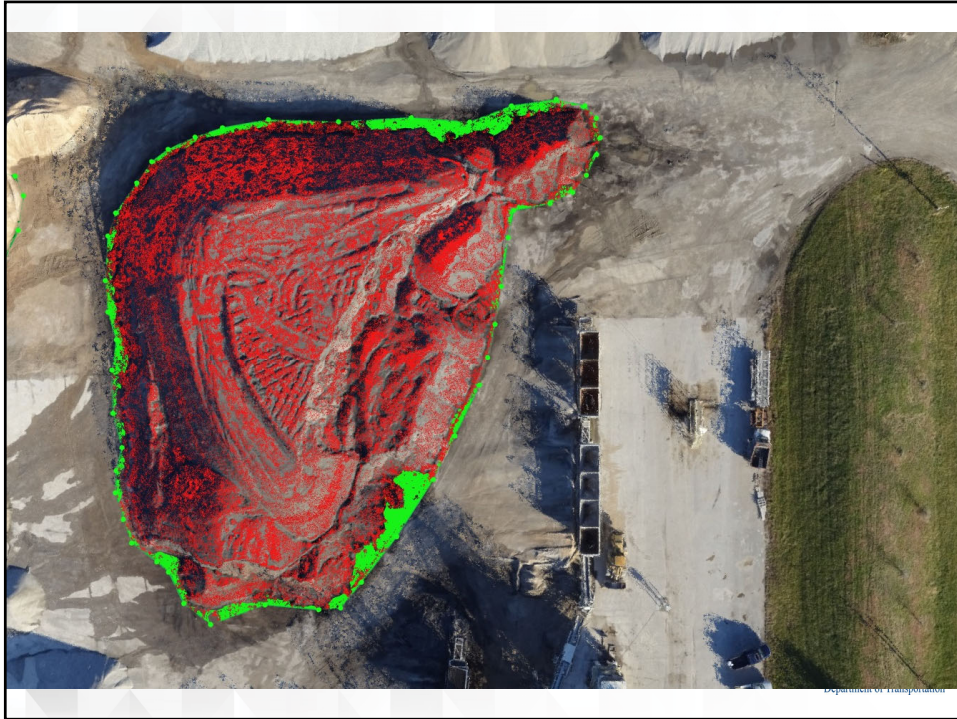



105



106

KANSAS SAND & GRAVEL BASICS (Sand 101)

by Steve Hatfield



DALE CARNEGIE® TRAINING Copyright 1996 © Dale Carnegie & Associates, Inc.

1

Introduction

Over 45 years in Sand business in Wichita area including 37 ½ with Ritchie Sand, a year with Lafarge after they bought Ritchie's & 9+ years now with Cornejo Materials.

- Been involved with all aspects of the Sand Business including Sales, Operations, Permitting & Transportation.
- Active with Kansas Aggregate Producer Association and National Stone Sand and Gravel Association and served on Board of Directors of both.
- Served on Advisory Board of Kansas Small Mine Safety and Kansas Geological Survey. Present & past involvement in a number of task groups and committees locally, on the state level and on the national level.



2

Sand Basics

- Sand & Gravel is not found just anywhere and not all deposits are created equal
- Kansas is fortunate to have an abundance of sand near most major metropolitan areas, although availability in some of these locations is diminishing
- In the central part of the state and west, the sand deposits are almost unlimited in quantity. However, permits for water limit where sand can be mined. In the northeast part of the state, the deposits are being depleted and regulated to the point that they are much less available than in the past. There is very little to no sand in the southeast part of the state.



3

Kansas Map Showing Saturated Deposits (Generally Sand)

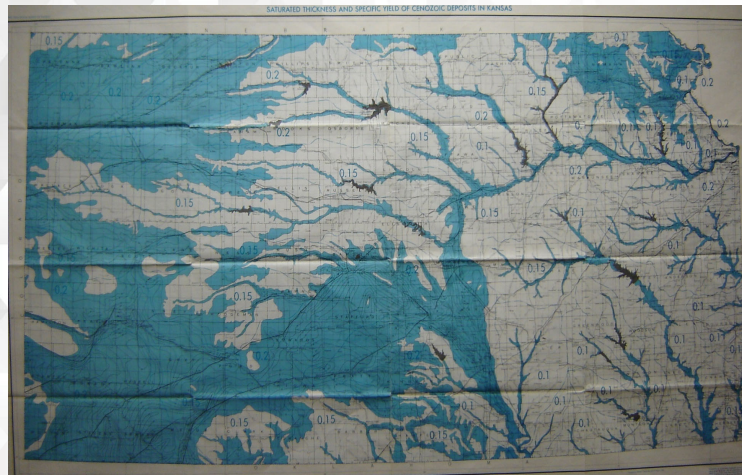

4

Some Sand Depths

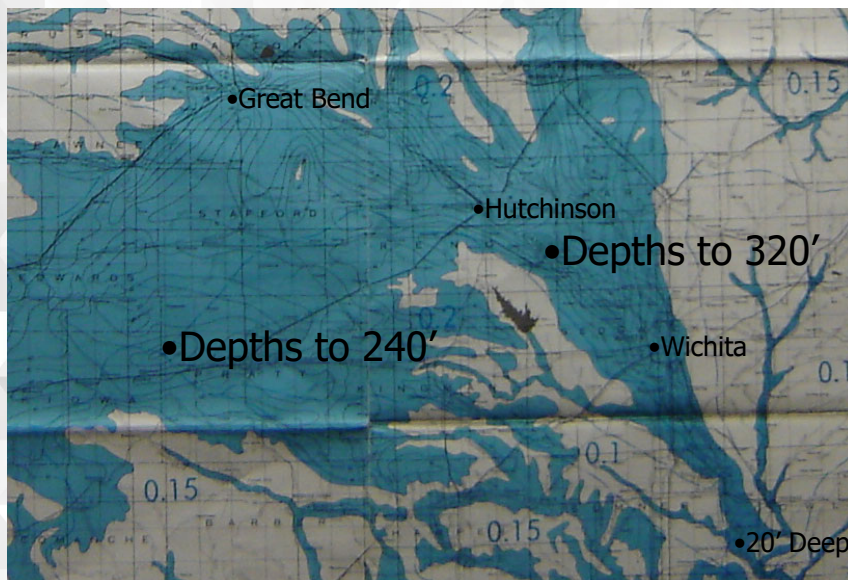

5

Differences in Deposits

- Most of the sand deposits in Kansas are within bodies of water. This can be in the rivers themselves or in the floodplains beside the rivers. These deposits require the use of a dredge or some other type of device, such as a drag line, to remove the material from under the water to process. This also exposes the deposit to evaporation.



6

- The reason I mention evaporation, is that in the Eastern 1/3 of Kansas we receive more precipitation through natural rainfall than would evaporate in a year. In the Western 2/3 of Kansas, more evaporates than can be replenished with natural rainfall. Because of this our sand operations must apply for & get Water Permits to operate. If an area has a lot of irrigation, Water Permits won't be available. We also must pay an annual fee on the estimated loss based on the acres we expose to evaporation.



7

Typical Sand Deposit near River



8

More on Deposits

- In the northwest part of the state, there are dry deposits that lie above the water and can be removed with loaders, backhoes, etc. and then processed. Frequently water is added to the process to clean and help with the sorting of the finer sizes.
- There are also some glacial deposits in the far northeast part of the state that are mined in various ways.
- There have been a few sand and gravel extractions in the southeast part of the state along the Neosho River in particular, but these are poorly graded deposits and due to endangered species, pretty much gone now.



9

Typical Dredge & Plant



10

Suction Dredge Basics

- As I explain to kids groups, a Suction Dredge is a floating vacuum cleaner that moves a lot of water instead of air to pick up a small amount of sand material and transport it through a pipeline to the plant
- At the plant the material is dewatered and processed to make the different sizes of product required for the intended market
- Dredges come in many sizes from a small 6" discharge pipe to a large 18" or 20" discharge that may pump up to 12,500 gallons per minute. The pumps can be mounted underwater for depths to 100' or more or mounted on a floating deck above the water line. They may be diesel, natural gas or electric driven.



11

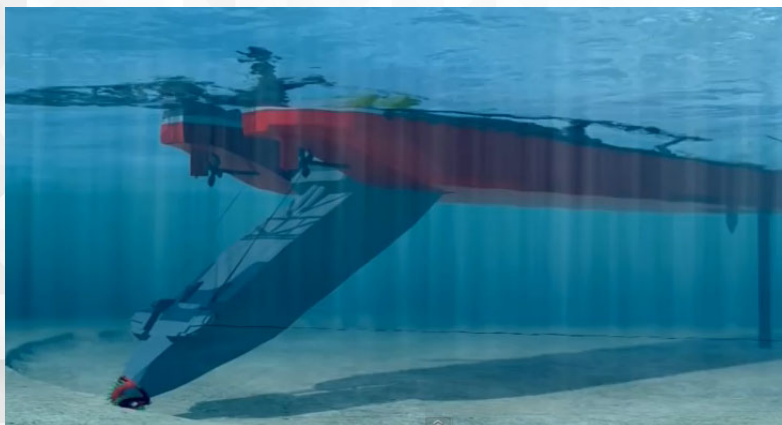

12



13



14

A Larger Dredge



15

A Very Larger Dredge



16

A Floating Dredge/Plant Combination



17

Sand Quality

- Most of the sand found in Kansas is clean. That may sound strange but we have very little silt, little deleterious material like lignite (except along the Missouri River in the northeast) and relatively free flowing deposits throughout the state. This means in general that we can mine the material, size the material and make a high quality aggregate for concrete and asphalt without too much additional work.
- However, the size of the material also varies widely across the state. As a general rule, the farther west you go in the state, the higher percentage of gravel there is to sand.



18

More on Sand Quality

- Gravel is defined as material larger than the 3/8" screen and sand is finer than the 3/8" screen.
- In the far western part of the state there is enough larger gravel to crush and make the needed coarse aggregate for mixes including Concrete Pavement. This frequently requires throwing away a large amount of sand that isn't needed in their markets.
- From about Great Bend to Wichita and south to the Oklahoma line, there is very little gravel in the deposits. The sand remains coarse enough to make high quality aggregates for concrete or asphalt, but due to the lack of gravel in the deposits, coarse aggregate like crushed limestone from farther east is required to make the mixes
- This is also true along the Kansas River basin and its tributaries.



19

Sand Processing

- Most sand processing begins with screening off the gravel. The gravel is processed by cleaning with a gravel washer, sizing on various size and types of screens, and/or crushing and sizing.



20

Plant Screen Section



21

Another Screen Section



22

More Sand Processing

- The material that passed the 3/8" screen is then classified. It would take a huge amount of screen to size the small particles in most sand products. A method of allowing the material to settle in a tank is called classification. The coarser particles settle faster than the smaller which stay suspended longer. By allowing all of the material to flow into a long tank, and placing a series of valves in the bottom of the tank, the various sizes can be sorted and rebled to make the specification required & excess water removed. Gravel can also be added back to make the coarser gradations needed.



23

Classification or Settling Tank



24

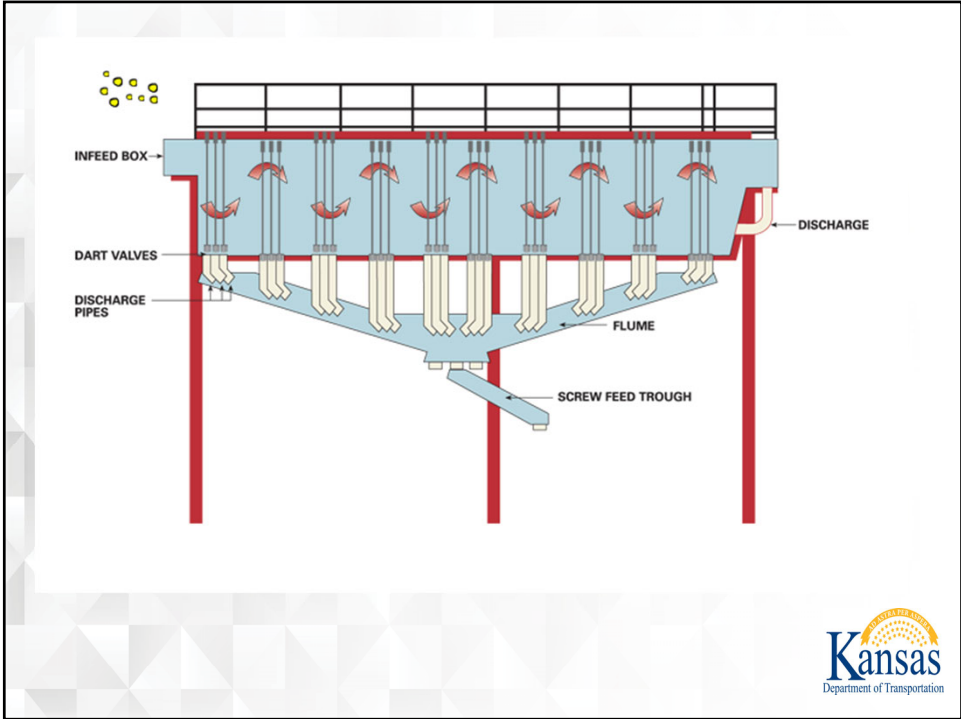

25

The material is then dewatered with dewatering screws or screens.

Views of a Dewatering Screw

Two photographs showing dewatering screws. The left photo shows a large red screw conveyor system in an industrial setting. The right photo is a close-up of two parallel red screws with yellow spiral blades, processing a dark material.

A logo for the Kansas Department of Transportation is in the bottom right corner.

26

View of a Dewatering Screen

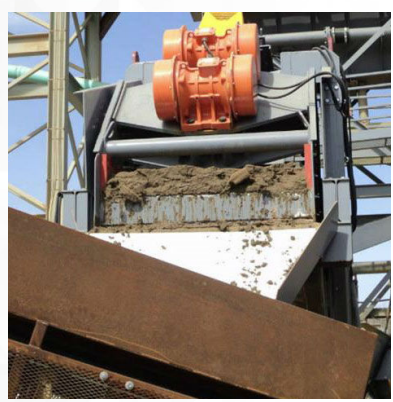

27

After dewatering the material is stockpiled and allowed to drain before being loaded. Most sand products don't have serious segregation problems unless they are coarse products or loaded out wrong.



28

Different Mixes Across the State

- As indicated earlier, sand is much more available in some locations than in others.
- The highest cost of most aggregates going in to a mix is the transportation to get it where you need it.
- So not all mixes used across the state of Kansas will be the same.



29

- It should stand to reason that in areas where sand is plentiful and stone must be hauled in from a distance, the amount of sand used in a mix will be much higher.
- Likewise, where sand must be transported a long distance, the coarser aggregate found locally will be used in a higher percentage.
- This is very true in concrete and less true in asphalt where other items are more important such as voids and angular material.



30

Permits & Regulations

- All mines require permits in the State of Kansas. Sand and Gravel are no exception and may include water permits, zoning permits, reclamation permits, floodplain permits, permits from the Corp of Engineers, etc.
- Be aware when you visit a site of these permits and what is required.



33

Hazards



34

- Hazards can include large equipment with limited visibility, truck traffic, falling material, deep water, high voltage electric cables & lines, and many others.
- Be aware when you visit a site of these and other hazards & what is required to be safe.



35

Mining & Mine Regulations

- All sand and gravel extraction operations are considered mines and regulated by the federal Mine Safety and Health Administration (MSHA).
- It doesn't matter who you are or who you work for, you are required to abide by these regulations.
- So don't blame the mine operator for requiring you to have hazard training, wear your PPE and check in and out when you need to visit these sites. It's required & we want you to be safe.



36

Summary

- Sand plants are located all across Kansas except in the Southeast corner
- Sand is plentiful over most of the state and of high quality
- Unlike crushing operations, the sand producer can't change the basic product, only the size by adding or removing.



37

- Sand is used in essentially all construction, from the foundation, to the sidewalk, the mortar holding the brick or block, the asphalt or concrete street, on the golf course, for filter media and a large number of other things.
- Sand is taken for granted and expected to be available for all of the above uses, but will become less available in the future due to regulations, depletion and urban development covering the reserves.



38



39



40

A Medium Size Sand Plant



41

A Large Complex Plant

2 million ton per year plant



42

Questions?



43

A Question for you:

What do you call a cat walking on a beach in December??



44

SANDY CLAWS - Of Course!!

Thank you for your attention.



CONSTRUCTION MANUAL PART V SECTION 5.6 REV 2018

Will likely need a large cup of coffee for this one.



1



2. Type of Production

- Aggregate production is classified into two groups according to the methods of operation. Commercial production is defined as production from a permanently established location that supplies aggregate to both commercial consumers and contractors performing KDOT work. Some producers may operate in some locations intermittently, depending on the market in that particular area, utilizing mobile plants; however, these locations remain established as a production sites and are still considered commercial producers.
- Non-commercial or roadside production is defined as aggregate production using portable plants that is incidental to other work being performed; for example, a highway cut section where rock is excavated and used by the contractor or sub-contractor for one or more materials that are needed on that particular project.

2



3. Inspection Responsibilities

- **3.1. Contractor Inspection**
- The Contractor performs or causes to be performed all inspections and tests necessary to provide and maintain an adequate process control system. An adequate process control system is one that provides that all aggregates or aggregate combinations submitted for acceptance will conform to contract requirements whether manufactured or processed by the Contractor or procured from sub-contractors or vendors.
- The Contractor is responsible for performing all process control activities for all aggregate and aggregate combinations during production, handling, stockpiling, blending, mixing, and placing operations.

3



3. Inspection Responsibilities (2)

- **3.2. Department Inspection**
- All aggregate acceptance tests will be conducted by the Department at the point of usage, unless designated otherwise by the Engineer. The Department reserves the right to run any test at any time or place to determine contract compliance. When test results on aggregates indicate non-compliance with contract requirements, the Engineer may reject the material and cause it to be removed at the Contractor's expense. If the aggregate is on a prequalified list or otherwise approved for use on the project, the Engineer still has the right to reject the material when test results indicate non-compliance with contract requirements.
- Department inspection does not replace the need for Contractor inspection or otherwise relieve the Contractor of responsibility to furnish acceptable aggregates.

4

- 4.1. General
 - Aggregate shall not be used for KDOT work until the deposit from which it is being produced and the production process has been approved. The aggregate producer shall determine and record the GPS coordinates where excavation is occurring. An aggregate source will be approved only after tests on "Official Quality" (OFQ) samples taken by a KDOT representative, or by the producer while under the direct supervision of a KDOT representative, have been completed and the test results show that aggregate produced from a specific deposit using a specific production process, meets the quality requirements of the contract documents. If the current OFQ fails, then the source will no longer be approved for projects not yet under contract until production is again approved.

5

- Tests on "Official Quality" samples taken to determine aggregate source approval are conducted in the Materials and Research Center at Topeka. The tests are as follows:
 - ALL AGGREGATES
 - ◆ Specific Gravity and Absorption (KT-6)
 - ◆ Acid Insoluble Residue (KTMR-28) (as requested)
 - COARSE AND MIXED AGGREGATE
 - ◆ Soundness (KTMR-21)
 - ◆ Wear (AASHTO T96)
 - ◆ Micro Deval (AASHTO T327)
 - FINE AGGREGATE (as requested)
 - ◆ Mortar Strength (KTMR-26)
 - ◆ Organic Impurities (AASHTO T21)
 - ADDITIONAL TESTING REQUIRED FOR CONCRETE AGGREGATES
 - ◆ Durable Aggregate Test (KTMR-22) (for coarse aggregates for on-grade concrete)
 - ◆ Wetting and Drying Test (KTMR-23) (for siliceous coarse aggregates for all concrete)

6

- It is the responsibility of the DME to see that aggregate deposits and processed aggregates are sampled and tested.
- It is the responsibility of the Field Engineer to confirm that aggregates comply with all applicable specifications prior to use. The delivery of aggregate to KDOT projects before OFQ tests show compliance with specifications is prohibited.

7

- 4.2. Basis of Approval
- 4.2.1. Active production sources
- Deposits approved on the basis of OFQ tests conducted on either processed (crushed, screened, washed, etc.) or "pit-run" production samples **remain approved if there are no significant changes in production or deposit characteristics or no other reasons to doubt the quality of the material.** Significant changes in production include but are not limited to: how ledge is quarried, equipment changes or modifications to include crushers, screens and wash plants, and changes in the production sequence. Significant changes in deposit characteristics include, but are not limited to: color change, bed thickness change, shale seam thickness change, and mineral changes. KDOT quarry and project inspection personnel, the contractor, and the aggregate producer shall be alert for any of these significant changes in production or deposit characteristics and any other events or conditions that may lead them to doubt the quality of the material. When changes or events occur, they should immediately notify the other involved parties and arrange for submission of new OFQ samples that reflect such changes. After the change, until the new OFQ results are determined, separate all material that could be affected by the change.
- The DME reserves the right to deny approval of aggregate sources which have a history of inconsistent test results or test results that fall below the specification limits even if the current OFQ passes.

8

- Once **approval** of aggregate from a specific source has been given to a contractor for use in a **specific project**, that approval will be **maintained for the duration of that project**; in the event that the project sample indicates deterioration of the product and if subsequent testing indicates the product no longer meets specification requirements, if inspection reveals deterioration of the product due to significant change in production or deposit characteristics, due to some unknown reason, or if field condition surveys demonstrate aggregate failure or aggregate deterioration that may lead to aggregate failure, material from that source will be discontinued immediately.
- **Should any sample taken from the project and submitted for quality testing fail, a new OFQ sample will be collected and submitted forthwith.** The results of the new OFQ sample will be used to determine whether further use of the material will be permitted on the project or whether the contractor will be required to obtain acceptable material from another source. The new OFQ sample test results will also be considered in determining approval of the material for use on future projects.
- In the event that **field condition survey** indicates deterioration of the product, the product from that source will be discontinued immediately and the DME will determine the role of that material for use on the project and use on future projects. Field condition surveys include, but not limited to: surveys performed by maintenance personnel, pavement management surveys, surveys conducted by Research, inspections by Headquarters, District, Area, and Subarea personnel, and any other field survey conducted under KDOT's authority.

9

- **4.2.2. Stockpiles**
- Stockpiles produced under contract will remain approved for use on that contract, **regardless of age**, as long as the quality remains acceptable. Aggregate produced and stockpiled at the quarry under an approved OFQ will be good for 2 years in the stockpile. Aggregate that has been stockpiled at the quarry for more than 2 years must pass verification testing before use on KDOT projects. **Do not add new production to existing stockpiles more than 2 years old before verification of the stockpile** and an OFQ of the current production have been completed.
- **4.2.3. Inactive Production Sources:** Samples taken from non-producing deposits will be tested for information only.

10

- **4.3. Appeal of Official Quality Test Results.**
- Aggregate producers must notify the DME if they wish to appeal OFQ test results. Two additional samples will be taken. Both samples must comply with the applicable specification(s) before approval is given. The first resample will be taken immediately after the results of the initial sample are made available and the producer has appealed. The second resample will be taken **after a minimum of 2500 tons have been produced**. If either of the two resamples fail, no further OFQ testing will be conducted on the location until the DME has determined the operations have moved a significant distance or there is a significant change in production or deposit characteristics as defined in section 5.6.4.2.1.
- **4.4. Department Discretion in Approving/Rejecting Aggregates and Adopting Standards.**
- KDOT has discretion to create, implement, and modify its standards, specifications, and testing procedures for aggregates as needed for the safety of the traveling public and proper expenditure of taxpayer funds. In its discretion, KDOT may find the standards, specifications, or testing procedures applicable to aggregates are not accomplishing the desired results. **Nothing in this Section 5.6 shall be construed as limiting KDOT's ability to reject aggregates based upon changes in standards, specifications, testing procedures, field performance or for other reasons determined by the Deputy Secretary and State Transportation Engineer.**

11

- **5.1. General**
- This section of the manual pertains to general policy covering aggregate source inspection and the frequency of and procedures for sampling aggregates for quality, production, and acceptance testing. The detailed methods to be followed when sampling are set forth in Section 5.9 of this manual.
- **5.2. Sampling for Quality Determination**
- **5.2.1. General Sampling Procedures**
- When obtaining OFQ samples, the Department representative must thoroughly examine the exposed portions of the deposit, record the GPS coordinates at the ledge face or location in the pit where production is occurring, and observe and document production and processing operations.
- Samples for OFQ should always be obtained from locations or from production points that will provide a representative sample of the aggregates that will be used for State work.

12

- Continued
- OFQ samples should be collected from current production. Quality samples obtained from stockpiles other than current production will only determine the acceptability of the aggregate in the individual pile.
- Tests for quality conducted on Verification Samples are not to be considered OFQ tests. Verification Samples are obtained only as a check on the quality of material being delivered to the project. KDOT will attempt to notify aggregate producers when aggregate Verification Samples are collected.

13

- Aggregate producers may use the sampling methods outlined in this section to obtain preliminary quality information from prospective aggregate deposits. Samples so obtained under the supervision of a representative of the Department may be submitted to the Materials and Research Center for information only testing. No charges will be made for such tests.
- When exploring for new locations or deposits, each producer will be permitted to submit a maximum of 10 samples for quality tests during each calendar year. No limit will be imposed on the number of samples a producer may submit from deposits explored for use on a specific project which has been advertised for letting. Exploration submittal requirements do not apply to currently producing locations.
- The DME will make "Official Quality" test results available to the producer.

14

- **5.2.1.1. Recording GPS Coordinates**
- Take GPS coordinates and enter into CMS in the decimal degree format ($xxx.xxxxx^{\circ}$) to five decimal places. Many GPS receivers use a default setting of degrees and decimal minutes ($xxx^{\circ} xx.xxx'$) or degrees, minutes and seconds ($xxx^{\circ} xx' xx.xx''$). Note that many receivers will display two digits when reporting degrees latitude and three digits when displaying degrees longitude. Latitude may additionally be indicated with an "N", "north", "lat", or positive sign on the display and longitude may be indicated by a "W", "west", "lon" or a negative sign. Enter ONLY numerals into CMS fields; do not enter any preceding text or positive/negative signs. Refer to the manual for the receiver for more information.

15

- The GPS receiver may revert to a default setting or inadvertently be changed to an incorrect format. Correct operation of the receiver and correct format should be checked each time the receiver is used. This can be accomplished by establishing coordinates for a reference point such as the corner of a sidewalk or a survey monument that can be checked each time the receiver is used. The reference point should be established in an area not likely to be disturbed and clear of overhead obstructions such as trees and nearby buildings. Verify that the receiver is set correctly to the decimal degree format and record the coordinates of the reference point for future use. Wait several minutes to get an accurate reading on the reference point. Two or more readings may be taken at different times to get an average. Due to the inherent nature of GPS receivers, when checking the receiver against the reference coordinates, the reading may vary on the order of 00.00010° (about 29 feet East/West or about 36 feet North/South) or possibly more. This is acceptable and not cause for concern. A variation of more than $.00015^{\circ}$ when checking the reference coordinates may indicate a problem with the setting or operation of the GPS receiver and should be investigated further.

16



5. Inspection, Sampling, and Testing (6)

- **5.2.2. Stone Deposits:**
- **5.2.2.1. Opened Deposits.**
- Commercial quarries and non-commercial quarries that are operational are sampled for OFQ from normal production.
- **Commercial stone from active production locations is sampled yearly. Intermittently producing locations are sampled each calendar year that aggregate is being produced or, for locations with mobile production equipment, each time the equipment is remobilized.** A contractor may still consider sources with a lapsed OFQ for contract bidding purposes provided the OFQ sample was taken within the last 1000 tons of production or the last week of production and the Quarry Inspector has evidence that no production has taken place since the mobile production equipment that produced the material for the OFQ had moved out. However, a current OFQ is required before the material is used on a project.

17



5. Inspection, Sampling, and Testing (7)

- **5.2.2.2. Unopened Deposits.**
- Unopened quarries are sampled by opening the quarry face the full depth of the usable ledge or ledges far enough back from exposure to reach unweathered stone. From this opening, the full depth of the finish face is shot down and a representative portion of the material is crushed at an operating quarry site by regular production crushing methods. The sample is obtained from this crushed product. Tests conducted on samples following this procedure will be for information only. **OFQ samples will be obtained from the processing plant (crusher, gradation unit) only after production at the site has commenced.**
- **Uncrushed ledge samples and drilled cores** are prepared in the Materials and Research Center to produce samples of proper size and gradation for testing. These samples are generally tested for **information only** and are not a basis for approval or disapproval of aggregate that will be used after crushing. **Uncrushed ledge samples are acceptable for OFQ samples when the stone is intended for use in the construction of +2" sized aggregate products or other miscellaneous uses.** The CMS inspection type for these samples is OQA.

18

- **5.2.3. Sand and Gravel Deposits:**
- **5.2.3.1. Definitions (Sand and Gravel)**
- "Pit Run" material shall be defined as sand or sand-gravel which, upon excavation, has been subjected to minimal processing or no processing at all. Such processing shall be limited to the removal of excess soil and/or oversize material. OFQ samples of sand or sand-gravel shall be "Pit Run" material if feasible.
- In the event that the quality characteristics exhibited by the "Pit Run" material do not meet the specification requirements for the intended product, the producer may utilize methods which will improve the aggregate quality by selective removal of some of the lower quality aggregate. OFQ samples may then be taken from the altered material.

19

- **5.2.3.2. Operating or Opened Deposits.**
- Commercial deposits and those under intermittent production are sampled for OFQ from normal production. Samples are to include all size fractions retained by the producer. Commercially operated deposits are to be resampled for OFQ when results from verification samples show significant variation from past results, and at least every five years. Non-commercially operated deposits are to be sampled at the direction of the DME.

20

- **5.2.3.3. Unopened Deposits.**
- Unopened deposits may be sampled prior to production by thoroughly drilling or otherwise sounding out the deposit. Samples taken for quality tests from unopened deposits will be for information only. OFQ samples will be taken from actual production.

21

- **5.2.4. Chat Deposits**
- Chat deposits are sampled by the most appropriate method. Chat piles or the products of screening plants from which material is being produced are sampled yearly for OFQ.

22

- **5.2.5. Lightweight Aggregate**
- Lightweight aggregate produced by expansion of clay, shale, or slate deposits, is sampled from the production site for initial prequalification. The Engineer of Tests will maintain prequalified listings of sources for Lightweight Aggregate for Concrete (PQL 3.2) and Lightweight Aggregate for Cover Material (PQL 3.3). Once prequalified, lightweight aggregate is sampled for verification directly from the project site. Lightweight aggregate sources will retain prequalified status unless a substantial change in the deposit or production process occurs, or unless verification test results indicate the material no longer meets specification requirements.

23

- **5.3. Coarse Aggregate for All Concrete**
- Although other classifications exist, generally, aggregates available for use in Kansas will be assigned one of two classifications: **siliceous** or **calcareous**. An aggregate's classification is typically only important when its use is intended for concrete.
- Siliceous aggregates contain the compound silicon dioxide. Some common examples of siliceous rock are natural sands and gravels, quartzite, and almost all igneous rock. Calcareous rock contains some form of calcium carbonate; the most common being limestone and dolomite.

24

- Siliceous coarse aggregates for use in concrete may require either additional testing to determine their potential for causing deterioration related to alkali-silica reaction (ASR) or mitigation of their ASR potential through use of a supplementary cementitious material (SCM).

- Any siliceous aggregate source wishing to supply coarse, intermediate, or mixed aggregate for concrete should be tested according to KDOT's Wetting and Drying Test of Sand and Sand-Gravel Aggregate for Concrete ([KTMR-23](#)). This testing determines a source's ASR potential and is performed on concrete produced with a total gradation of aggregate from the source being evaluated; therefore, sources must be able to supply a gradation that meets the middle 1/3rd of the MA-1 grading. The Engineer of Tests will maintain a complete record of each source tested and the test results. The Engineer of Tests will prepare and distribute the prequalified List of Non-Reactive Siliceous Aggregate Sources for Concrete (PQL 3.1), also known as the "Wetting and Drying List".

- Siliceous aggregate sources that are not singly able to provide one of the MA gradations or do not pass the wetting and drying test are not necessarily precluded from use in concrete. However, approval of concrete mix designs that utilize such aggregates will be contingent upon the contractor **incorporating a coarse aggregate sweetener or using an SCM to mitigate the ASR**, as described in Section 1102 of the Standard Specifications.

27

- **5.4** Coarse Aggregate for On-Grade Concrete
- **5.4.1.** General
- On-Grade Concrete Aggregates (OGCA) are **subject to additional testing** that is performed on concrete produced with OGCA to determine if acceptable levels of freeze/thaw resistance are provided in order to reduce the risk of the occurrence of premature deterioration. OGCA are intended for use in "on-grade" concrete such as Portland cement concrete pavement, sidewalk, curb, gutter, etc. Prequalification of OGCA material is granted on a geologic unit basis for each unit in a quarry face and to individual pits for sandgravel sources. OFQ sampling and testing is also required. The acceptance of OGCA is contingent upon production being from approved units and in compliance with OFQ requirements.

28

- The Engineer of Tests will maintain a complete record of each source tested and the test results. The Engineer of Tests will prepare and distribute the prequalified List of Freeze/Thaw Resistant Coarse Aggregate Sources for On-Grade Concrete (PQL 3.4). This listing will be included with the prequalified materials list and will be updated monthly. The PQL will list the following information for each approved source: state (if outside of KS), county, quarry number, producer's name, producer's CMS identification number, legal description, geological unit name or type (if applicable), bed number(s) (if applicable), the date of completion for the most recent production sample, and the date of the last geologic inspection (if applicable).

29

- **5.4.2. Initial Prequalification of Sources**
- **5.4.2.1. Initial Request Procedure**
- The DME is responsible to initiate KDOT's prequalification activities for sources in their respective District. Upon receipt of a written request from a producer, the DME will forward a copy of the written request to the Chief Geologist and the Engineer of Tests. The Chief Geologist will determine whether an initial geologic inspection is appropriate.

30

- **5.4.2.2. Initial Geologic Inspection Procedure**
- **Some quarries can be separated into beds, and the KDOT Geologist will do this whenever possible. Other quarries and sand and gravel deposits cannot be separated into beds. These locations will be separated into ledges or geologic units whenever possible. The term “unit” will be used to describe all these scenarios.**

31

Crushed Stone Quarry

- The Chief Geologist will arrange for a geologist to meet with District inspection personnel at the quarry. The geologist is responsible for preparing a KDOT Quarry Report (including GPS coordinates and color photographs) for the quarry. The quarry report will include identification and detailed description of each geologic unit present in the quarry face. Producers have the option of submitting ledge samples or production samples for initial testing for prequalification determination.

32

Crushed Stone Quarry

- Ledge samples are hand-picked samples collected by the geologist directly from the quarry face. Ledge samples will be taken from each geologic unit in the quarry face, unless the producer wishes to specifically preclude any units from initial prequalification determination. If the producer opts to forego ledge sampling, an initial production sample must be obtained from the production of each individual geologic unit. It is the producer's responsibility to maintain adequate separation of the units through all phases of production and sampling.
- A plan view of the quarry indicating the location(s) in the quarry that are intended to be mined for OGCA must be provided by the quarry operator prior to sampling. The plan view must show appropriate landmarks for future reference.

33

Sand-Gravel Pit

- Typically, gravel pits will not require a full geologic inspection prior to initial sampling. However, the DME should become familiar with the production site, process, general depositional characteristics, and other items that could potentially influence the quality of the material being produced prior to production sampling.

34

- **5.4.2.3. Prequalification Testing Procedures**
- All samples will be tested at KDOT's Materials and Research Center (MRC) to determine which sources and/or individual geologic units meet the additional requirements for OGCA. If the crushed stone producer opted to submit ledge samples, two production samples from complying units, singly or in combination, must meet the additional requirements for OGCA before prequalification status is granted. **If the producer opted to forego ledge sampling for initial prequalification determination, the initial production sample will be considered the first of the two required production samples.** Sand-gravel sources must submit production samples for prequalification testing, therefore only one additional sample must meet the requirements for OGCA. Sand-gravel sources must have the last two passing production samples to meet the requirements for OGCA. **For both crushed stone and sand-gravel, the two production samples must be separated by a minimum of 2500 tons of production.**

35

- Due to the timing differences between inspection, production, and testing activities, it is possible for a producer to have its production sample(s) submitted before the initial sample testing is complete. KDOT reserves the right to delay the testing of subsequent samples until the initial samples indicate compliance with the specification or to terminate testing on subsequent samples if at any point it is determined that a geologic unit or source will fail to meet the specification requirements for OGCA.
- Once a source has two passing production tests on file with KDOT, the source will be added to PQL 3.4. Should a source fail to pass prequalification testing, resampling will not be permitted until significant changes occur or until the producer can provide reasonable explanation of why the testing failed and a plan for addressing the issue in the future. Requests for resampling should be made in accordance with the guidelines for initial prequalification. Exceptions to this process will require approval of the Chief of Construction and Materials.

36



5. Inspection, Sampling, and Testing (26)

- **5.4.3. Inspection of OGCA Production**
- **5.4.3.1. Approved Production Plan**
- The DME will obtain a written production plan for OGCA from the producer prior to providing inspection. The production plan shall include but not be limited to the following information (as applicable): the location(s) that will be mined; the approved unit(s) that will be mined; and the procedures that will be used to prevent any non-approved material from mixing with the OGCA throughout the entire mining, hauling, crushing, stockpiling, and shipping processes. Producers shall provide updated production plans to the DME at the beginning of each production season, or as otherwise determined by the DME, and any time significant changes occur in production or deposit characteristics as defined in section 5.6.4.2.1.

37



5. Inspection, Sampling, and Testing (27)

- **5.4.3.2. Aggregate Source Inspection Requirements**
- The DME is assigned the responsibility to provide periodic inspection of aggregate production operations to verify that OGCA produced for Department work is produced from only the approved locations and/or geologic unit(s). In addition, the DME is responsible for **verifying that the production process is essentially the same** as that used to produce the aggregates selected for the OGCA production tests. The proper level of inspection is to be determined by the DME based on the unique circumstances encountered at each source.
- **KDOT quarry inspectors must familiarize themselves with the plan view of the production facility, the OGCA production plan, and the KDOT Quarry Report (if applicable).** These three documents should provide the inspector with sufficient information to verify that only approved material is being produced from approved locations and that the aggregates are processed in the appropriate manner. Inspectors are required to document their inspection activities during each visit to the site. The documentation is to be kept in a diary or other hard copy form approved by the DME.

38

- **5.4.3.3.** Notification of shipment

- **Producers** shall notify the DME responsible for inspection of OGCA production prior to producing and shipping such aggregates to concrete production sites for use on KDOT projects. The DME will then provide proper inspection during OGCA production and notify the appropriate Construction Office of the pending delivery of OGCA.

39

- **5.4.4** Production Sampling

- It is the responsibility of the DME to collect aggregate samples for production testing. Reassignment of such responsibility between DME's may be made when mutually agreeable. Documentation of such reassignments should be disseminated to concerned parties.

- It is the responsibility of the contractor to notify the DME of all potential sources of on-grade concrete for a project under contract. The DME will arrange for production sampling of aggregate at each concrete production facility utilized for on-grade concrete as required by the frequency given in Section 5.6.5.4.4.1.

- When practical, the quarry inspectors **should visit concrete production sites** to assist project personnel with identification of OGCA produced and hauled from sites they inspect and to assist in the collection of production samples. **KDOT will attempt to notify the aggregate producer at least 24 hours in advance of when OGCA production samples are collected from a concrete production plant.**

40

■ 5.4.4.1. Sampling Frequency and Location

Sampling from Aggregate Production Site

- A minimum of one production sample must be collected annually from the aggregate production site when OGCA is being provided to KDOT projects. Samples of non-calcareous aggregate produced from sources outside Kansas may be collected annually from the point in which they are shipped into Kansas.

Sampling from Contractor Concrete Production Plant

- A minimum of one production sample representing each 20,000 tons of OGCA must be obtained for each producer from the plant where on-grade concrete is being produced.

■ 5.4.4.1. Sampling Frequency and Location

Sampling from Ready-Mix Concrete Production Plant

- A minimum of one production sample representing each 5000 tons of OGCA must be collected from any concrete ready-mix plant that is producing on-grade concrete for KDOT.
- The DME has discretion for adjusting sampling frequencies at any site to provide adequate assurance of material quality. The DME will inform the producer when the frequency will be adjusted and provide the reason for doing so.

- **5.4.4.2. Testing**

- Collected samples are to be delivered to the Engineer of Tests. The Engineer of Tests is responsible for testing the samples and for comparing the test results with the historical test data for that source. The Engineer of Tests will issue test result reports and notify the DME and the producer of test results in a timely manner.

- **5.4.5. Continuation of Prequalified Status**

- When any person feels that any change in the prequalified status of an aggregate/source of aggregate is warranted, that person should notify the DME responsible for quarry inspection who in turn will advise the Chief of Construction and Materials. The Chief of Construction and Materials will review all available information and render a decision on any such changes. Official notification of any change in OGCA prequalification status for a quarry will be provided by the Engineer of Tests to the quarry owner/operator and the appropriate contractors.

- In addition to a significant change in production, as defined in section 5.6.4.2.1 or other reasons that cause the Department to doubt the quality of the aggregate, any of the following occurrences may warrant a resample and/or immediate change in the prequalification status of a source:

- **5.4.5.1. Geologic Changes**

- When geologic changes are identified, the DME, the Chief Geologist, and the Chief of Construction and Materials should be immediately notified. The Chief Geologist will determine whether a new geologic inspection and re-testing of units is required. The Chief of Construction and Materials will determine whether the source is allowed to remain on PQL 3.4 or allowed to be used for OGCA to projects under contract with or without restrictions or conditions

45

- The following are considered geologic changes:

Changes in the Deposit

- All personnel responsible for QC at the production site or concrete plant (Contractor, Producer, KDOT quarry monitors and inspectors, etc.) have the right and responsibility to monitor for significant changes in the deposit characteristics. Typical examples of such changes would be a significant color change in any of the units being produced, a significant change in thickness of any unit(s) in the quarry face, the addition or complete disappearance of any unit(s) in the quarry face, a significant change in the type or amount of fossils observed in any unit(s), or an increase of the deleterious materials in the aggregate.

46

- The following are considered geologic changes:

Significant Change in Production Location

- Generally, mining operations are considered to have made a significant change in production location when they have moved 1/4 mile or more from the most recent inspection site.

Geologic Inspection Expiration

- Geologic site inspections are good for two years from the date the inspection was completed. It is the producer's responsibility to contact the DME and request a new geologic inspection prior to the current inspection's expiration.

- **5.4.5.2. Failed Material**
- When failing material is identified, the DME and the Chief of Construction and Materials should be notified and the source will be immediately removed from PQL 3.4. **The Chief of Construction and Materials will determine whether the source is allowed to be used for OGCA to projects under contract with or without restrictions or conditions.**
- Failing material can be identified either through OFQ testing, production sample testing, or through field condition surveys as defined in section 5.6.4.2.1 of existing pavements. A source will be evaluated for failing field performance if its stone is used for OGCA on a state highway project and the completed on-grade concrete shows evidence of aggregate caused deterioration prior to 20 years of life.

- 5.4.5.3. Lapse of Prequalification Requirements
- If a source's OFQ or geologic inspection expires, or if 18 months have elapsed since the source's last production sample was completed, the source may remain on the PQL at the discretion of the Chief of Construction and Materials. A contractor may still consider sources with lapsed status for contract bidding purposes; however, the source must renew its geologic inspection, **submit a production sample with a passing test result**, and/or have a current OFQ, whichever are applicable, **before any material** from the lapsed source will be accepted on a KDOT project.
- It is the contractor's responsibility to communicate with potential OGCA producers to determine if any of these conditions exist prior to bidding work and to verify all specification requirements have been met prior to delivering the aggregate to the project.

49

- 5.4.5.4. Procedure for On-Grade Concrete Aggregate Removal
- Prior to KDOT removing an aggregate source from its "List of Prequalified Aggregates Sources for On-Grade Concrete" (the "PQL") due to a failing test, the Engineer of Tests will average the three most recent KTMR-22 Relative Dynamic Modulus of Elasticity (RDME) test results for the aggregate. If the RDME 3-point rolling average is 96 or greater, then the aggregate will remain on the "List of Prequalified Aggregates Sources for On-Grade Concrete" (the "PQL") provided the expansion is below 0.025%.
- In the event KDOT removes an aggregate source from its "List of Prequalified Aggregates Sources for On-Grade Concrete" (the "PQL") for failure to meet KDOT requirements the following applies
- 5.4.5.4.1. Removal Procedure (See Construction Manual)

50



5. Inspection, Sampling, and Testing (40)

- 5.4.5.4.3. Time
- Nothing in 5.6.5.4.5.4. prevents KDOT and a quarry owner from entering into a written agreement to modify the time limits specified herein upon mutual consent.
- 5.4.5.4.4. Department Discretion
- For purposes of OGCA, whether a change in production or deposit characteristics is significant and whether an event or condition is significant is determined by the Bureau Chief of Construction and Materials.
- Nothing in 5.6.5.4.5.4. is intended to restrict or preclude KDOT from modifying its procedures for removal of aggregates for on-grade concrete pavement if KDOT determines the specified procedure(s) is/are not in the best interest of KDOT, the State of Kansas, or the traveling public.
- 5.4.6. Process of Returning to PQL Following Removal.
- In the event an on-grade concrete aggregate source on PQL 3.4 is removed by KDOT, the process for the quarry owner to seek re-inclusion of the aggregate on the PQL is that set forth in in section 5.6.5.4.2. Before KDOT will begin re-inspection, the owner or producer shall provide evidence of changes in geology or production process that warrant re-inspection. The request should be submitted to the Chief of Construction and Materials who will review the owner's/producer's justification for re-inspection, testing history, field performance history, and any other pertinent data to determine whether to allow or deny reinspection. The procedure for re-inspection will follow the initial prequalification procedure described in Section 5.6.5.4.2.

51



5. Inspection, Sampling, and Testing (41)

- **5.4.7. Stockpiles**
- Stockpiles produced under contract will remain approved for use on that contract, regardless of age, as long as the quality remains acceptable during production.
- A producer wishing to stockpile OGCA must provide a production plan detailing such activities as described in Section **5.6.5.4.3.2**. Production sampling for stockpiles will be at the same interval given in Section **5.6.5.4.4.1**. Stockpiles constructed under approved OFQ and approved production testing will remain approved for two years from the date of the last production sample that represents the stockpile.

52



QUARRY INSPECTION CLASS



1



Concrete (401)

SECTION 401

GENERAL CONCRETE

401.1 DESCRIPTION
 Provide the grades of concrete specified in the Contract Documents.
 See **SECTION 402** for specific requirements for Structural Concrete.
 See **SECTION 403** for specific requirements for On Grade Concrete.
 See **SECTION 404** for specific requirements for Prestressed Concrete.

401.2 MATERIALS
 Provide materials that comply with the applicable requirements.

Aggregate	DIVISION 1100
Admixtures and Plasticizers	DIVISION 1400
Grade 2 Calcium Chloride	DIVISION 1700 (1702)
Cement, Fly Ash, Silica Fume, Slag Cement and Blended Supplemental Cementitious..	DIVISION 2000
Water	DIVISION 2400

2

401.3 CONCRETE MIX DESIGN

- a. General.** Design the concrete mixes specified in the Contract Documents.
- Do not place any concrete on the project until the Engineer approves the concrete mix designs. Once the Engineer approves the concrete mix design, do not make changes without the Engineer's approval.
 - Take full responsibility for the actual proportions of the concrete mix, even if the Engineer assists in the design of the concrete mix.
 - Provide aggregate gradations that comply with DIVISION 1100 and Contract Documents.
 - Admixture dosage rate requirements for mix design approval and field production are provided in subsection 401.3k.
 - If desired, contact the DME for available information to help determine approximate proportions to produce concrete having the required characteristics on the project.
 - Submit all concrete mix designs to the Engineer for review and approval. Submit completed volumetric mix designs on KDOT Form No. 694 and all required attachments at least 60 days prior to placement of concrete on the project. The Engineer will provide an initial review of the design within 5 business days following submittal.

3

b. Concrete Mix Design Based On Previous Data.

Provide concrete mix designs based on previous 28-day compressive strength test data from similar concrete mixtures. Similar mixtures are within 1000 psi of the specified 28-day compressive strength, and are produced with the same type and sources of cementitious materials, admixtures and aggregates.

Consider sand sources the same, provided they are not more than 25 miles apart on the same river and no tributaries enter the river between the 2 points. Consider crushed locations similar if they are mined in one continuous operation, and there is no significant change in geology. Mixes that have changes of more than 10% in proportions of cementitious materials, aggregates or water content are not considered similar.

4

b. Testing of Aggregates.

(1) Production of On Grade Concrete Aggregate (OGCA). If OGCA is required, notify the Engineer in writing at least 2 weeks in advance of producing the aggregate. Include the source of the aggregate and the date production will begin. Failure to notify the Engineer, as required, may result in rejection of the aggregate for use as OGCA. Maintain separate stockpiles for OGCA at the quarry and at the batch site and identify them accordingly.

(2) Testing Aggregates at the Batch Site. Provide the Engineer with reasonable facilities at the batch site for obtaining samples of the aggregates. Provide adequate and safe laboratory facilities at the batch site allowing the Engineer to test the aggregates for compliance with the specified requirements.

5

- KDOT will sample and test aggregates from each source to determine their compliance with specifications. Do not batch the concrete mixture until the Engineer has determined that the aggregates comply with the specifications. KDOT will conduct sampling at the batching site, and test samples according to the Sampling and Testing Frequency Chart in Part V. For QC/QA contracts, establish testing intervals within the specified minimum frequency.
- After initial testing is complete, and the Engineer has determined that the aggregate process control is satisfactory, use the aggregates concurrently with sampling and testing as long as tests verify compliance with specifications. When batching, sample the aggregates as near the point of batching as feasible. Sample from the stream as the storage bins or weigh hoppers are loaded. If samples cannot be taken from the stream, take them from approved stockpiles, or use a template and sample from the conveyor belt. If test results indicate an aggregate does not comply with specifications, cease concrete production using that aggregate. Unless a tested and approved stockpile for that aggregate is available at the batch plant, do not use any additional aggregate from that source and specified grading until subsequent testing of that aggregate indicate compliance with specifications. When tests are completed and the Engineer is satisfied that process control is satisfactory, production of concrete using aggregates tested concurrently with production may resume.

6

c. Handling of Materials.

(1) Approved stockpiles are permitted only at the batch plant and only for small concrete placements or for maintaining concrete production. Mark the approved stockpile with an "Approved Materials" sign. Provide a suitable stockpile area at the batch plant so that aggregates are stored without detrimental segregation or contamination. At the plant, limit stockpiles of tested and approved coarse, fine and intermediate aggregate to 250 tons each, unless approved for more by the Engineer. If mixed aggregate is used, limit the approved stockpile to 500 tons, the size of each being proportional to the amount of each aggregate to be used in the mix.

7

(5) Separation of Materials in Tested and Approved Stockpiles. Only use KDOT Approved Materials. Provide separate means for storing materials approved by KDOT. If the producer elects to use KDOT Approved Materials for non-KDOT work, during the progress of a project requiring KDOT Approved Materials, inform the Engineer and agree to pay all costs for additional material testing.

8

SECTION 1116

AGGREGATES FOR ON GRADE CONCRETE (OGCA)

1116.1 DESCRIPTION

This specification is for coarse aggregates, intermediate aggregates, fine aggregates, mixed aggregates (coarse, intermediate and fine material) and miscellaneous aggregates for use in construction of concrete placed on grade.

For Intermediate Aggregates and Mixed Aggregates, consider any aggregate with 30% or more retained on the No. 8 sieve to be Coarse Aggregate.

9

1116.2 REQUIREMENTS

Quality of Individual Aggregates.

(1) Provide aggregate for concrete that complies with the following requirements. Crushed aggregates with less than 20% material retained on the 3/8" sieve from a source complying with these requirements prior to crushing. Fine Aggregates for Concrete have additional Quality Requirements stated in subsection 1116.2e.(2).

Soundness by Freeze/Thaw (min.) (KTMR-21)*	0.90
Wear Grading B (max.)(AASHTO T 96)**	50%
Additional Requirements:***	
Soundness by Freeze/Thaw (min.) (KTMR-21)	0.90
Relative Dynamic Modulus of Elasticity, minimum (KTMR-22 @ 660 F/T cycles)	95
Expansion, maximum (KTMR-22 @ 660 F/T cycles)	0.025%

* Soundness (KTMR-21) requirements do not apply to aggregates having less than 10% material retained on the No. 4 sieve.

** Wear (AASHTO T 96) requirements do not apply to aggregates having less than 10% retained on the No. 8 sieve.

***The additional requirements do not apply for uncrushed sand-gravel aggregates having less than 5% material retained on the 1/2" sieve.

10

(2) All predominately siliceous aggregate must comply with the Wetting & Drying Test requirements, or be used with a Coarse Aggregate Sweetener, or will require Supplemental Cementitious Materials (SCM) to prevent Alkali Silica Reactions (ASR). When an SCM is utilized, provide the results of mortar expansion tests of ASTM C 1567 using the project's mix design concrete materials at their designated percentages. Provide a mix with a maximum expansion of 0.10% at 16 days after casting. Provide the results to the Engineer at least 15 days before placement of concrete on the project.

Wetting & Drying Test of Siliceous Aggregate for Concrete (KTMR-23)

Concrete Modulus of Rupture:

At 60 days, minimum	550 psi
At 365 days, minimum	550 psi

11

Expansion:

At 180 days, maximum	0.050%
At 365 days, maximum	0.070%

Aggregates produced from the following general areas are exempt from the Wetting and Drying Test:

Blue River Drainage Area.

The Arkansas River from Sterling, west to the Colorado state line.

The Neosho River from Emporia to the Oklahoma state line.

(3) Coarse Aggregate Sweetener. Types and proportions of aggregate sweeteners to be used with Mixed Aggregates are listed in **TABLE 1116-1**.

12

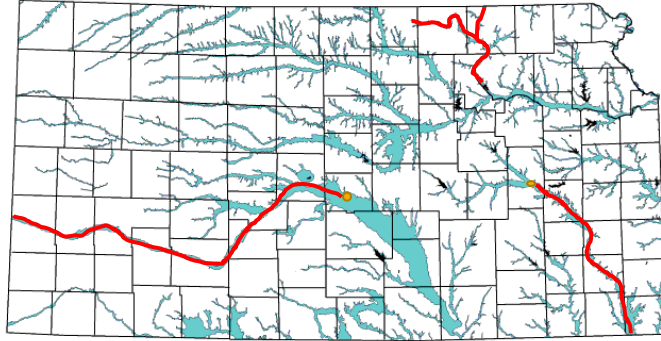

- Blanket Approval --
- Ark River from Colorado Border to Sterling KS
- Blue River Drainage
- Neosho River from Emporia to Oklahoma Border

TABLE 1116-1: COARSE AGGREGATE SWEETENER

Type of Coarse Aggregate Sweetener	Proportion Required by Percent Weight
Crushed Sandstone*	40 (minimum)
Crushed Limestone or Dolomite*	40 (minimum)
Siliceous Aggregates meeting subsection 1116.2a.(2)	40 (minimum)
Siliceous Aggregates not meeting subsection 1116.2a.(2) **	30 (maximum)

*Waive the minimum portion of Coarse Aggregate Sweetener for all intermediate and fine aggregates that comply with the wetting and drying requirements for Siliceous Aggregates. In this case, combine the intermediate, fine and coarse aggregate sweetener in proportions required to comply with subsection 1116.2a.(2)
 **To be used only with intermediate and fine aggregates that comply with the wetting and drying requirements of Siliceous Aggregates unless a Supplemental Cementitious Material is utilized.

(3) Handling of All Aggregates.

(a) Segregation. Before acceptance testing, remix all aggregate segregated by transit or stockpiling.

(b) Stockpiling.

- Maintain separation between aggregates from different sources, with different gradings or with a significantly different specific gravity.
- Transport aggregate in a manner that promotes uniform grading.
- Do not use aggregates that have become mixed with earth or foreign material.
- Stockpile or bin all washed aggregate produced or handled by hydraulic methods for 12 hours (minimum) before batching. Rail shipment exceeding 12 hours is acceptable for binning provided the car bodies permit free drainage.
- Provide additional stockpiling or binning in cases of high or non-uniform moisture.
- Stockpile accepted aggregates in layers 3 to 5 feet thick. Berm each layer so that aggregate do not “cone” down into lower layers.

Certification of Aggregates. Provide the Engineer a certification for each classification of aggregate utilized in a project.

(1) Aggregates Delivered to the Site: Certify each classification of aggregate delivered to a project or product preparation site. Prepare these certifications under the signature of the aggregate producer or their designated representative.

(a) Certify aggregates that are tested at their destination to determine final disposition as to the locations of the deposits from which they were produced.

(b) Certify aggregates that are tested at their production site to determine final disposition. These certifications state that the aggregates were removed from a KDOT tested and approved stockpile at the production site, or that they were removed from a plant while it was producing aggregate that was in compliance with the applicable specifications.

(2) Aggregates Incorporated into the Project: At locations where aggregates and products that incorporate aggregates are produced for KDOT and non-KDOT use, provide certifications stating that only KDOT tested and approved aggregate were provided for KDOT projects.

(3) Frequency of Certification:

(a) Before the initial delivery of aggregates to a project or product preparation site, provide the Engineer a certification. This certification is to be under the signature of the aggregate producer or their designated representative and states that all aggregates to be provided for the project are in compliance with all the applicable KDOT specifications.

(b) Upon completion of the project, provide certifications as specified in **1101.2c.(1),(2)** to the Engineer. These certifications apply to all aggregates that were delivered to the project or product preparation site and ultimately used in the project.

17

These certifications are to **indicate the approximate quantities in tons or cubic yards of each aggregate delivered to the project** and the approximate quantities in tons or cubic yards of each aggregate delivered to the product preparation site and incorporated into a product that was utilized in the project.

(4) Certification **Requirement for Chat**: Sellers of chat must complete and submit the Chat User's Certificate within 30 days of the date of acquisition. The certification will contain the following information: location of origin of the chat, amount of chat acquired, and a certification that the chat will be used in accordance with the criteria of Chat Rule, 40 Code of Federal Regulations (CFR) Part 278. The certification should be submitted to both the Kansas Department of Health and Environment (KDHE) and to the Bureau of Construction and Materials. If the chat is sold or otherwise transferred to another party, the seller shall provide a copy of the certification to the new owner of the chat. The initial or any subsequent acquirer of chat will maintain copies of the following for a minimum of 3 years: a) a copy of the certification following transmittal to KDHE, and, as appropriate, b) any Synthetic Precipitation Leaching Procedure testing results, or c) any site specific risk assessments.

18



Aggregate Certification

- Form 649
- Referenced in 2015 Std. Specs. 1101
- All Information is Required
- Used to Check Mix Designs
- Used to Check Verification Information

19



Aggregate Certification (2)

KANSAS DEPARTMENT OF TRANSPORTATION

CERTIFICATION OF AGGREGATES USED BY _____
(Producer or Contractor name)

KDOT CONTRACT NUMBER _____

KDOT PROJECT NUMBER _____

Aggregate Description	Quantities Tons or Cu Yards	Location of Deposit			County	Ledge, Beds, or Thicknesses	KDOT Quality CMS. No.
		Sec.	Twp.	Range			
1.							
2.							
3.							
4.							
5.							

This is to certify (check applicable box)

All the aggregates described above:

(A) That will be provided to the project are in compliance with all applicable specifications.

(B) That were provided to the project were in compliance with all applicable specifications.

CMS Producer Code _____

Name of Producer _____

Date _____

Signature _____ Title _____

KDOT FORM 649

20

1101.4 PREQUALIFICATION

- With the exception of Lightweight (expanded shale) Aggregate, aggregates from each source require "Official Quality" testing on samples obtained by an authorized representative of KDOT before use on KDOT projects. These samples are taken from actual production, which may be "pit-run", "crusher-run" or may involve some processing. Approved sources remain approved only if there are no major changes in the production methods or deposit characteristics.

- Lightweight (expanded shale) Aggregate must be prequalified. In-state producers wishing to get their product prequalified must submit a written request to the District Materials Engineer for the District in which the production facility is located. Out-of-state producers must submit their written request to the Engineer of Tests. In the request, the producer must specify whether they want the material to be used for Modified Lightweight Aggregate [**subsection 1102.2.e.(2)**] or for Cover Material (**subsection 1109**). Samples will be collected by KDOT and tested for compliance with applicable specifications. Lightweight aggregates that comply with all applicable requirements will be added to a list of prequalified lightweight aggregates maintained by the Bureau of Construction & Materials. Any change in material source, equipment, or process voids the prequalification and a new prequalification will be required.

21

1101.5 BASIS OF ACCEPTANCE

Aggregates from sources approved for the intended use are accepted based on the following:

- a. Current official quality test results complying with the requirements of the applicable subsection are on file with KDOT or the aggregate source is named on an applicable Prequalified List (PQL).

- b. Results of tests conducted on samples taken at a point or points designated by the Engineer. KDOT reserves the right to re-sample, test and reject any previously accepted aggregate if the Engineer has reason to believe it no longer complies with the Contract Documents.

- c. Certifications as specified in **subsection 1101.2 c.**

22

Quarry Monitor CIT Class

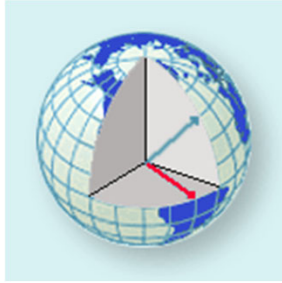

Mapping & GPS
Basics



1

LOCAL MAPPING Public Land Survey System (TRSQ)



2

Public Land Survey System

Standardized surveying system established in 1785

KS & NE Territories Authorized in 1854

Base Line is the KS – NE Border (40°)

Established & Measured from the 6th Principal Meridian (approx 97.36°)

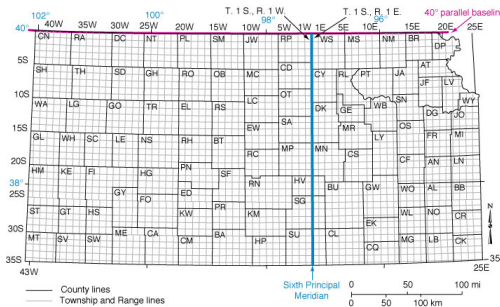

Image Courtesy of KGS: http://www.kgs.ku.edu/Publications/pic20/pic20_1.html



3

Public Land Survey System ⁽²⁾

Townships are 6 mile areas N to S Ranges are 6 mile areas E to W

So each square area defined by a Township and Range is 36 square miles. Each of these Square miles is called a Section.

Sections are numbered from the NE corner going west, then south one, and back to the east in a zigzag pattern.

Each section can be divided and sub-divided into corners or quarters.

Standard designation is down to quarter section.

Often referred to as TRSQ (Township-Range-Section-Quarter)

One section = 640 acres

One $\frac{1}{4}$ section = 160 acres

So the typical 40 acre lot is $\frac{1}{4}$ of $\frac{1}{4}$ of 1 section.



4

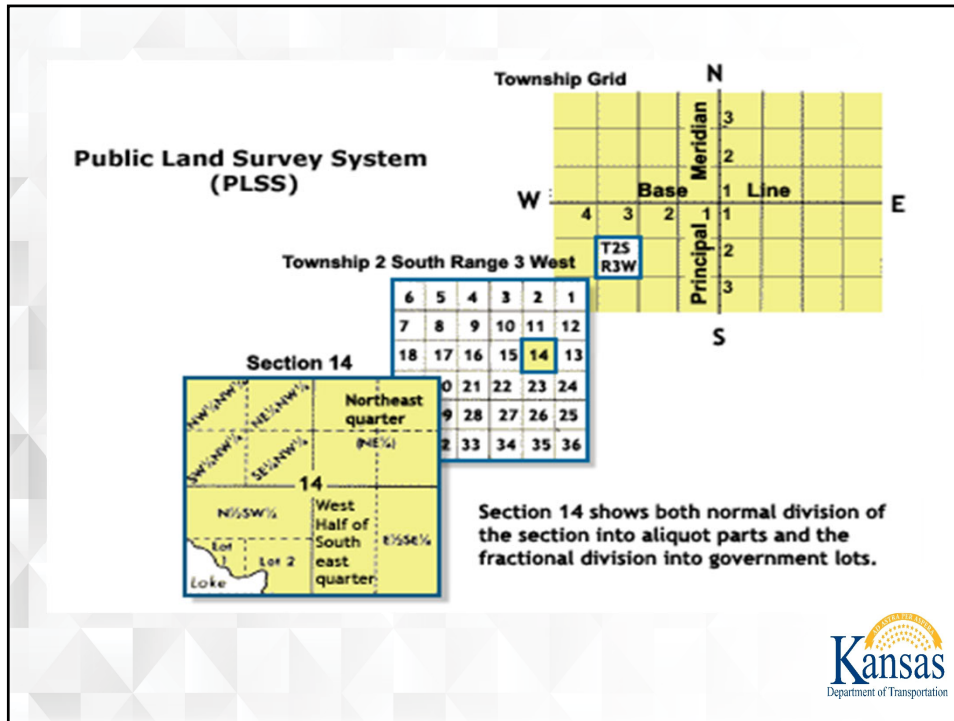

5

GLOBAL MAPPING

Latitude and Longitude

6

Latitude

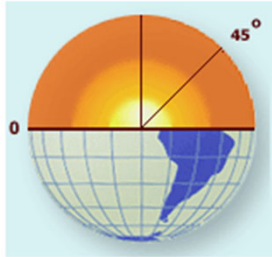

Earth is a sphere spinning about an axis that runs through the poles

Latitudinal lines (parallels) measure angular distance from the midpoint between the poles otherwise known as the Equator

Latitudinal lines are parallel and equal distance to each other

The Equator is given 0° lat and the poles are at $\pm 90^\circ$



7

Did You Know?

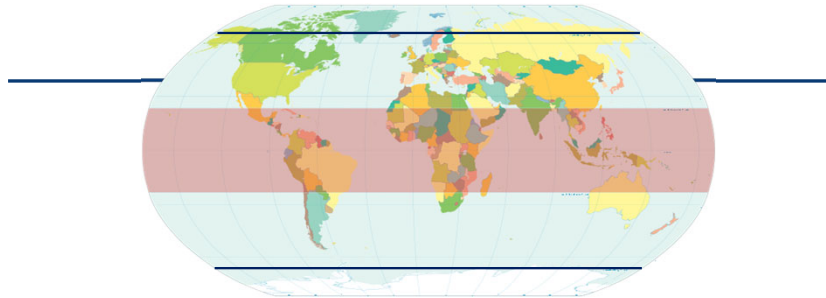

Tropic of Cancer at 23.43944° Tropic of Capricorn at -23.43944°

Arctic Circle at 66.56756° Antarctic Circle at -66.56756°

What's their significance?



8

Just for Fun

During the Solstices:

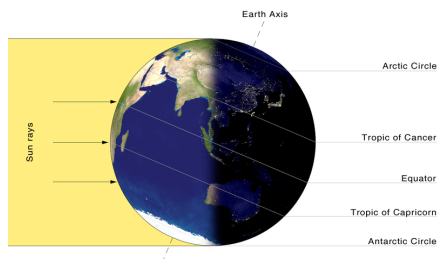

The tropics are the furthest boundary where the sun is directly overhead.

The Arctic/Antarctic circles mark the boundaries of 24 hour day and night



9

Longitude

Longitudinal lines (meridians) run perpendicular to latitudinal lines and intersect at the poles

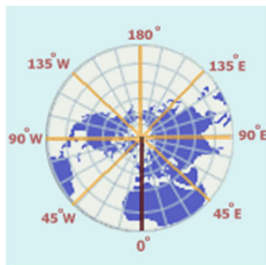

No definitive starting point so in 1884, the 21st President convened the International Meridian Conference where 41 delegates from 25 nations met in D.C. to decide which meridian was to be given the value of 0° longitude



10

Fun Quiz

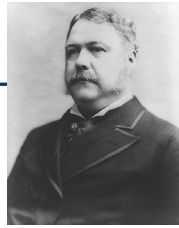

Who was the 21st President?

Chester A. Arthur

What is the 0° meridian called?

The Prime Meridian

What city does it run through?

Greenwich, England



11

Longitude cont.

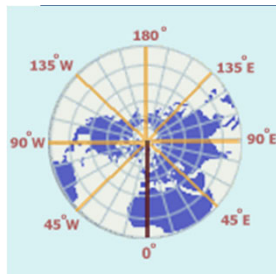

Earth has 360° of longitude, expressed as 0° to 180° (180° line is known as International Date Line)

Distance between longitudinal lines varies with distance from equator

What's the significance of the International Date Line?

Crossing it going east subtracts a day, going west adds a day.



12

Sign / Directional Conventions

Latitude/Longitude = Lat/Long = Northing & Easting

Negative latitude is south or can be designated with "S" (-45° vs. S 45°)

Similarly with longitude, negative is same as west (-90° vs. W 90°)

For KDOT purposes, we know our producers aren't located in the middle of the Pacific Ocean or the middle of Asia, so we omit the sign or letter designation from official documentation.

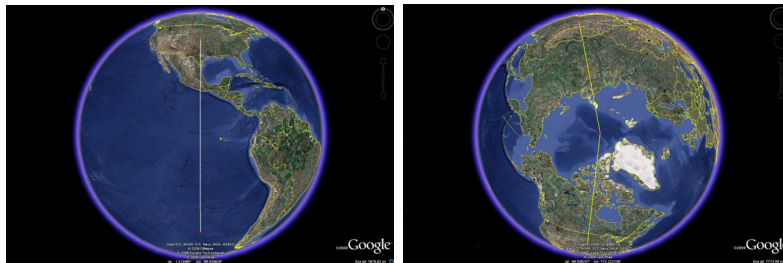

13

Fun Quiz (2)

If you travel straight south from the southern tip of Florida until you reach the equator, where will you be?

The Pacific Ocean



14

Defining Exact Points

A degree of lat or long represents a relatively large distance on the face of the earth

A degree of latitude is approximately 69 miles

At the equator, a degree of longitude is also approximately 69 miles; at a latitude of 38° (Kansas), a degree of longitude is approximately 54 miles

Degrees can be broken down using a decimal (38.78987°) or into Degrees, Minutes, and Seconds (38°47'23.54")

Typical GPS Unit's default format is D,M,S.....

KDOT standard is decimal degrees to 5 decimal places!



15

FUN QUIZ ⁽³⁾

There are: 360° in a circle, 24 hours in a day, 54 miles in a degree.....

So how fast do you have to fly westward across the earth's surface in the center of KS to keep up with the sun?

$$360^\circ / 24 \text{ hrs} = 15^\circ / \text{hr} \quad 15^\circ \times 54 \text{ miles} = 810 \text{ miles} \\ 810 \text{ mph!}$$



16

Converting D,M,S to Decimal Degrees and Vice-Versa

Decimal degrees are just like any other numeral expressed in decimal format.

Minutes and Seconds are just divisions of degrees

there are 60' (minutes) in a degree and

there are 60" (seconds) in a minute

To convert D,M,S to Decimal Degrees:

$\text{Deg} + \text{Min}/60 + \text{Sec}/3600 = \text{Decimal Degrees}$

$38^{\circ}47'23.54'' = 38 + 47/60 + 23.54/3600 =$
 $0.78333 + 0.00654 = 38.78987^{\circ}$

38 +

To convert Decimal Degrees to D,M,S:

Multiply numbers right of the decimal by 60, the whole number result is minutes, repeat that step again to get seconds

$38.78987^{\circ} = (38^{\circ}) 0.78987 \times 60 = 47.3922 (47') 0.3922 \times 60 = 23.53$
(23.53")



17

Lat/Long Ranges for KS & Midwest

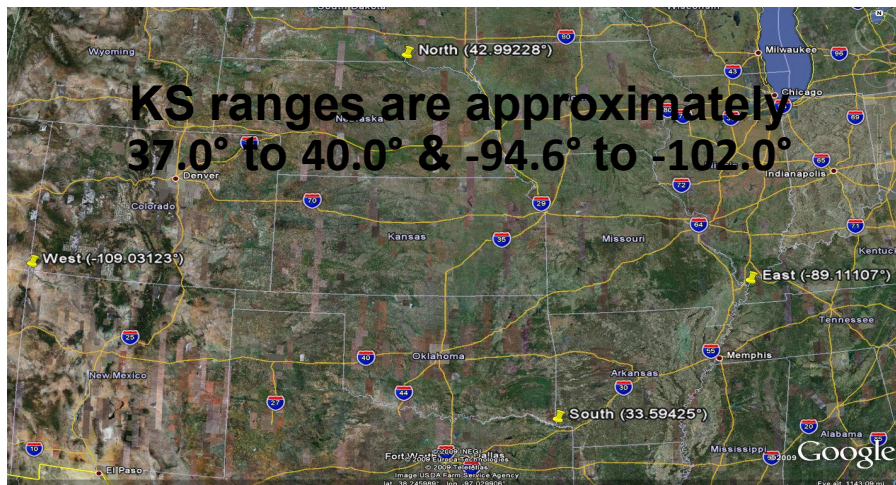

18

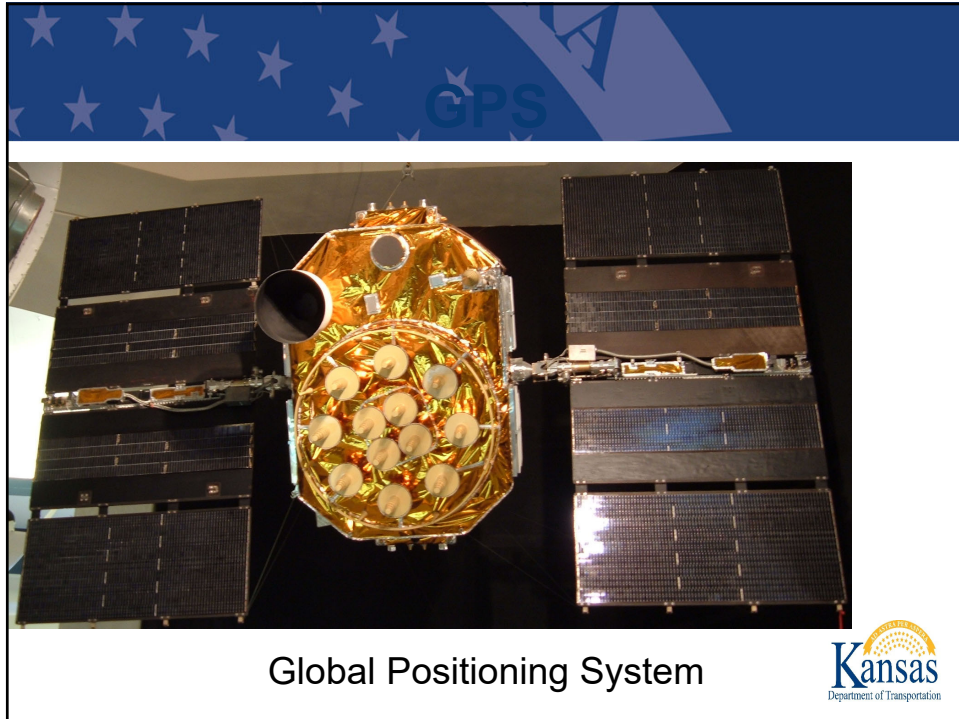

19

How does GPS Work?

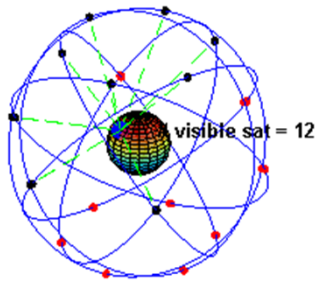

24 Satellites orbiting at around 12,000 miles are constantly monitored by the Department of Defense

Position of each satellite is known to extreme accuracy

Each satellite is equipped with an atomic clock

Satellites emit a string of pseudo random code by radio signal



20

“In a Nutshell”

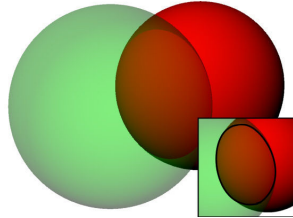

Receiver calculates it's distance from one satellite using timing difference in the code

Distance from one satellite represented as a sphere (receiver is somewhere on its surface)

Two spheres intersect creating a circle.

A circle and third sphere intersect creating two points of intersection

- One of the points is either too far away from earth's surface or moving too fast to be the correct point

- However, if the receiver used that assumption to define the location it would still be WAY OFF!

Why?

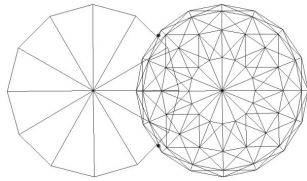

21

GPS Error



Satellites use atomic clocks for extreme accuracy....handhelds would cost about \$50K to \$100K each

Instead, the receiver uses a fourth satellite

- The sphere from this satellite will not intersect either of the two points the other 3 satellites found

- Receiver calculates a correction factor that can be applied to all four satellites to make them intersect

- VOILA, an atomic clock in the palm of your hand and an exact position on earth!

There are many errors the receiver must account for: varying signal speed through atmospheric changes, signal reflection, etc.

So the more satellites in view of your receiver and the longer you wait for it to stabilize it's position, the better the accuracy will be!

*"Correcting errors" images courtesy of Trimble
<http://www.trimble.com/gps/howgps-error.shtml>*

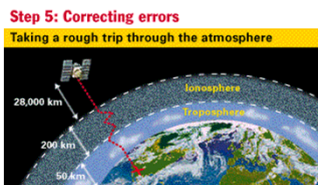

22

Tips and Tricks

GPS Unit should be checked to make sure it's set up (displaying decimal degrees) and operating properly prior to EACH use.

This can be accomplished by checking a "reference point".

- Identify a location free from overhead obstructions, that will not likely be moved or destroyed and permanently mark it.
- Allow the GPS unit to establish a "hard point" by waiting several minutes (this should be done EVERY time a location is recorded).
- Record the location coordinates (multiple readings taken at various times can also be used to average the location's coordinates).
- Return to the reference point to verify correct operation of the GPS unit.



23

Accuracy....

Typical accuracy of hand-held GPS unit is 10 ft or 0.00003°
(under ideal conditions)

☆ Acceptable variance when checking reference point is
0.00010°

36 ft N-S and 29 ft E-W

☆ Deviations of more than 0.00015° should be investigated

54 ft N-S and 44 ft E-W

☆ Taken from Part V



24

So What's the Point?



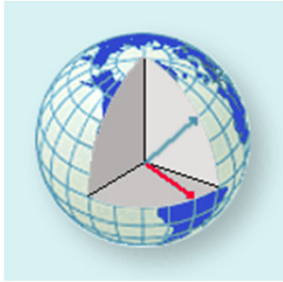

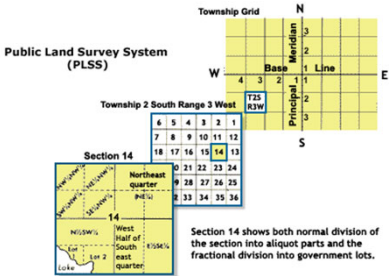

Public Land Survey System (PLSS)

Township Grid

Township 2 South Range 3 West

Section 14

Section 14 shows both normal division of the section into aliquot parts and the fractional division into government lots.



25

When/Why do we need it?

Legal Description (TRSQ), Lat/Lon, and GPS Coordinates should be entered in CMS sample information fields.

Construction Manual Part V:

- Producer must use GPS to track production location.
- You must record GPS coordinates for the location where OFQ samples are collected. These coordinates should be entered into CMS.
- GPS coordinates must go into the Quarry Report for Class I/II ledge and production sampling.
- GPS coordinates are needed for 3-way split sample locations. They should be entered into CMS and included on the HMA Specific Gravity List. This location is the aggregate source, NOT the crusher or stockpile. (Pending exclusion for imported aggregates sampled from stockpiles at shipping facilities in KS.)



26

Useful Tools

 Google Earth

<http://dl.google.com/earth/client/current/GoogleEarthWin.exe>

Excellent tool for verifying locations and cross-checking GPS coordinates.

An all around useful tool for ANYONE who does field work.

Earth Point - Tools for Google Earth

<http://www.earthpoint.us/townships.aspx>

Web Site to convert GPS to TRSQ & vice-versa

Also has an overlay app that will display TRSQ info in Google Earth, and give lat/long coordinates for a section's center and corners



27

Fun Quiz ⁽⁴⁾

What is Google Earth's default location?

An apartment complex, just north of 15th St. & Crestline Dr. in Lawrence, KS

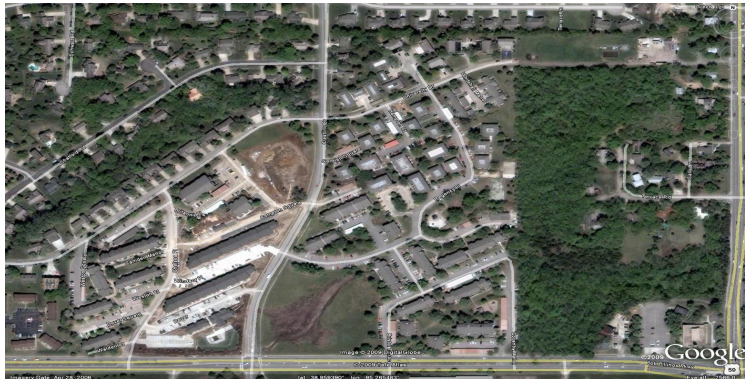

28

Questions?





1

1114 - STONE FOR RIPRAP, DITCH LINING AND OTHER MISCELLANEOUS USES

SECTION 1114

STONE FOR RIPRAP, DITCH LINING AND OTHER MISCELLANEOUS USES

1114.1 DESCRIPTION
 This specification covers stone for the following uses:

- Riprap
- Aggregate Ditch Lining (D₅₀)
- Filter Course
- Flumes, Flume Drains and Slope Drains
- Tree Wells or Cribs
- Shot Rock
- Granular Drainage Blanket
- Sediment Basin Risers

Where referred to, quarried stone is defined as limestone, dolomite, calcite cemented sandstone, rhyolite, quartzite, basalt and granite, removed from naturally occurring formation by standard extraction and sizing methods. Recycled PCCP may be used for Riprap, Ditch Lining, and Shot Rock, provided the respective Soundness and Wear requirements are met.

1114.2 REQUIREMENTS
a. Stone for Riprap.

(1) Composition. Provide quarried stone for riprap that meets the installation class specified in the Contract Documents.

(2) Quality.

- Soundness, minimum (KTMR-21) 0.85
- Wear, maximum (AASHTO T 96) 45%
- Inspection of the quarry ledge, stock piles, and available sites where comparable stone from the same bed(s) is in service to verify the Product Control requirements have been met.

(3) Product Control.

- Provide stone for riprap that is free of soil, shale or shale-like material and cracks, seams or other defects that will decrease the durability of the material after placement.
- Provide riprap from sources that have been inspected and approved by the **KDOT Geologist**.
- A riprap source may be rejected if more than 15% of the product from the source deteriorates within 5 years of exposure, either in service or in a natural weathering test plot (such as a boulder pile at the quarry). Deterioration is defined as any one piece losing more than 25% of its original volume either due to damage during handling and placement or due to cracking or splitting as a result of weak seams in the rock. Determination is made by visual inspection.
- Size. The class requirements are given in **TABLE 1114-1**.

2

15-11001-R01
Sheet 1 of 1

**KANSAS DEPARTMENT OF TRANSPORTATION
SPECIAL PROVISION TO THE
STANDARD SPECIFICATIONS, 2015 EDITION**

**SECTION 1114
STONE FOR RIPRAP, DITCH LINING AND OTHER MISCELLANEOUS USES**

Page 1100-35, subsection 1114.2a(3). Add the following to the end of subsection 1114.2a(3):

- Field Inspection Method to determine acceptable material size.
- Measure a minimum of 3 sides of the boulder.
- Use a density of 150 lbs. per cubic foot to calculate the weight of the boulder. (Weight = Volume * Density)
- On visible faces, measure the length of the boulder at a minimum of 3 locations; average the measurements to establish the dimensions and calculate the volume.
- Example calculation to determine the approximate weight:
Volume: 1.5 feet x 1.5 feet x 1.5 feet = 3.375 cubic feet;
Weight: 3.375 cubic feet x 150 lbs. per cubic foot = 506.25 lbs.
- Any dispute of calculated measurements of weights can be determined from actual weight of the boulder in question.

Page 1100-36, subsection 1114.2a(3). Delete TABLE 1114-1 and replace with the following:

TABLE 1114-1: STONE FOR RIPRAP*

Class	Percent Heavier Than											
	4 tons	3 tons	2 tons	1 1/2 tons	1 tons	3/4 tons	1/2 tons	250 lbs.	200 lbs.	100 lbs.	75 lbs.	5 lbs.
HEAVY												
2 Ton	0		50+			75+		90+				
1 1/2 Ton		0		50+		75+		90+				
1 Ton			0		50+		75+	90+				
3/4 Ton				0		50+			90+			
1/2 Ton					0		50+			90+		
3/4 Ton						0		50+			90+	
LIGHT												
200 Lb.							0	0-5		50+		95+
100 Lb.								0	0-5		50+	95+
Facing									0		50+	95+

*Percent of total sample weight composed of pieces heavier than the indicated weight

06-18-15 BSGS (RWD) Typographical Correction to TABLE 1114-1
Aug-15 Letting

3

Geology Investigations

- What we are looking for

4



- Geology Investigations-cont.
- What we are looking for
 - Stockpiles / Boulders that have been exposed for a long period of time

5



1114 - STONE FOR RIPRAP, DITCH LINING AND OTHER MISCELLANEOUS USES

SECTION 1114

STONE FOR RIPRAP, DITCH LINING AND OTHER MISCELLANEOUS USES

1114.1 DESCRIPTION

This specification covers stone for the following uses:

- Riprap
- Aggregate Ditch Lining (D₂₅)
- Filter Course
- Flumes, Flume Drains and Slope Drains
- Tree Wells or Cribs
- Shot Rock
- Granular Drainage Blanket
- Sediment Basin Risers

Where referred to, quarried stone is defined as limestone, dolomite, calcite cemented sandstone, rhyolite, quartzite, basalt and granite, removed from naturally occurring formation by standard extraction and sizing methods. Recycled PCCP may be used for Riprap, Ditch Lining, and Shot Rock, provided the respective Soundness and Wear requirements are met.

1114.2 REQUIREMENTS

a. Stone for Riprap.

(1) Composition. Provide quarried stone for riprap that meets the installation class specified in the Contract Documents.

(2) Quality.

- Soundness, minimum (KTMR-21) 0.85
- Wear, maximum (AASHTO T 96) 45%
- Inspection of the quarry ledge, stock piles, and available sites where comparable stone from the same bed(s) is in service to verify the Product Control requirements have been met.

(3) Product Control.

- Provide stone for riprap that is free of soil, shale or shale-like material and cracks, seams or other defects that will decrease the durability of the material after placement.
- Provide riprap from sources that have been inspected and approved by the KDOT Geologist.
- **A riprap source may be rejected if more than 15% of the product from the source deteriorates within 3 years of exposure, either in service or in a natural weathering test plot (such as a boulder pile at the quarry). Deterioration is defined as any one piece losing more than 25% of its original volume either due to damage during handling and placement or due to cracking or splitting as a result of weak seams in the rock. Determination is made by visual inspection.**
- Size. The class requirements are given in TABLE 1114-1.



6



7



8



9



10

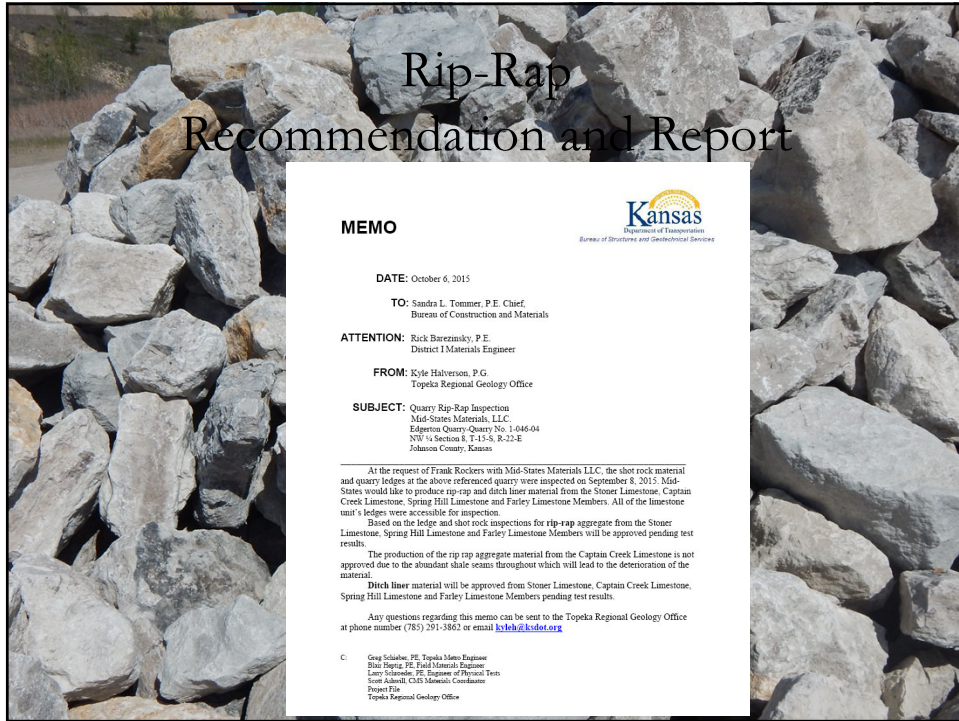

11

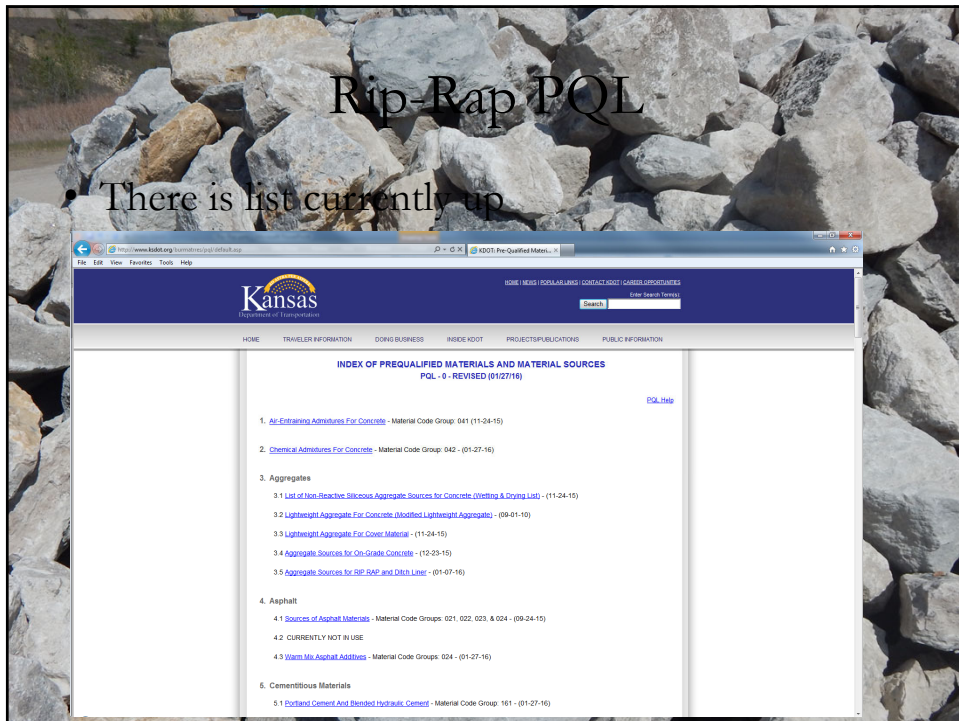

12

Aggregate Sampling



1

Sample Size

**Construction Manual Part V
Section 5.5 – 2.1**



2

Sample Size

2.1.1. Aggregates for Quality Testing

2.1.1.1. Official Quality (OFQ) requirements for **soundness** do not apply for aggregates having less than 10% material retained on the No. 4 (4.75 mm) sieve.

2.1.1.2. OFQ requirements for **wear** do not apply to aggregate having less than 10% materials retained on the No. 8 (2.36 mm) sieve.

2.1.1.3. Crushed aggregates with less than 10% material retained on the No. 4 (4.75 mm) sieve (excluding mineral filler supplements) must be produced from a source complying with the official quality requirements prior to final processing.



Sample Size

Material	Sample Size
Crushed Stone	Two 50 lb (23 kg) bags of -1" (-25.0 mm), + #8 (+2.36 mm) material. Select a grading from Table 1 based on the predominant particle size of the sample material and make certain the minimum size fraction amounts outlined in Table 1 are included in the 100 lb (45 kg) sample. Additional bags of individual sized material may be submitted to assure these minimums. A sample graded in accordance with the requirements of Table 2 shall also be submitted.
Fine Aggregate for Concrete	50 lbs (23 kg) of pile run material.
Chat or Sand-Gravel	50 lbs (23 kg) of + #8 (+2.36 mm) material plus 50 lbs (23 kg) of pile run material. A sample graded in accordance with the requirements of Table 2 shall also be submitted.
Aggregate for Wetting & Drying Test	300 lbs (135 kg) of Sand-Gravel graded to meet the middle 1/3 of the MA-1 grading.



Sample Size

Table 1 - Minimum Mass Requirements for Crushed Aggregate Soundness Tests

Sieve Size		Grading and Mass, lbs (kg)		
Passing	Retained On	I	II	III
1" (25.0 mm)	3/4" (19.0 mm)	20 (9)		
3/4" (19.0 mm)	3/8" (9.5 mm)	15 (7)	30 (14)	
3/8" (9.5 mm)	No. 4 (4.75 mm)	6 (3)	10 (5)	35 (16)
No. 4 (4.75 mm)	No. 8 (2.36 mm)	6 (3)	6 (3)	10 (5)

Table 2 - Grading of Wear Test Samples

Sieve Size		Grading and Mass, lbs (kg)			
Passing	Retained On	A	B	C	D
1-1/2" (37.5 mm)	1" (25.0 mm)	10 (5)			
1" (25.0 mm)	3/4" (19.0 mm)	10 (5)			
3/4" (19.0 mm)	1/2" (12.5 mm)	10 (5)	20 (9)		
1/2" (12.5 mm)	3/8" (9.5 mm)	10 (5)	20 (9)		
3/8" (9.5 mm)	1/4" (6.3 mm)			20 (9)	
1/4" (6.3 mm)	No. 4 (4.75 mm)			20 (9)	
No. 4 (4.75 mm)	No. 8 (2.36 mm)				40 (18)



5

Sample Size

2.1.2 Lightweight Aggregates for Prequalification

Material	Sample Size
Lightweight Aggregate for Concrete	<p>400 lbs (180 kg) of pile run material. Select a grading from Table 1 based on the predominant particle size of the sample material, and make certain the minimum size fraction amounts outlined in Table 1 are included in the 400 lb (180 kg) sample. Additional bags of individual sized material may be submitted to assure these minimums.</p> <p>A sample graded in accordance with the requirements of Table 2 shall also be submitted.</p>
Lightweight Aggregate for Cover Material	<p>100 lbs (45 kg) of pile run material. Make certain the minimum amounts for III Grading from Table 1 are included in the 100 lb (45 kg) sample. Additional bags of individual sized material may be submitted to assure these minimums.</p> <p>A sample graded in accordance with the C Grading of Table 2 shall also be submitted.</p>



6

Sample Size

2.1.3. Aggregates for Verification Samples

Material	Sample Size
Crushed Stone	<p>100 lbs (45 kg) of pile run material. If the #4 (4.75 mm) and #8 (2.36 mm) retained material is not available in the amounts outlined in Table 1, it may be obtained from finer material delivered to the project if the finer material is from the same source as the coarser material. If finer material from the same source is not delivered to the project, then a Soundness test will be conducted.</p> <p>A sample graded in accordance with the requirements of Table 2 shall also be submitted.</p>
Fine Aggregate for Concrete	50 lbs (23 kg) of pile run material.
Chat or Sand-Gravel	<p>100 lbs (45 kg) of pile run material.</p> <p>A sample graded in accordance with the requirements of Table 2 shall also be submitted.</p>
Lightweight Aggregates	<p>100 lbs (45 kg) of pile run material. Sample size may be increased to ensure the minimum amounts from Table 1 are included in the sample.</p> <p>A sample graded in accordance with the requirements of Table 2 shall also be submitted. For Cover Material, provide a C Graded sample.</p>



Sample Size

2.1.4. On Grade Concrete Aggregates

Material	Sample Size
Ledge Sample	300 lbs (135 kg) per bed, hand-picked from the ledge.
Production Samples	<p>80 lbs (35 kg) of material passing the 3/4" (19.0 mm) sieve and retained on the 1/2" (12.5 mm) sieve.</p> <p>80 lbs (35 kg) of material passing the 1/2" (12.5 mm) sieve and retained on the 3/8" (9.5 mm) sieve.</p>



Sampling Aggregates

- Follow procedures in KT-01 in Part V of the Construction Manual.



9

Form 652

- When inspecting and sampling from a quarry or pit, the Form 652 book can be utilized for multiple uses.
- Within the book is the Quarry Monitor Checklist, Sample Table, and pages to document information about the sampling, production, quarry faces, etc.



10

Form 652 ⁽²⁾

Quarry Monitor Checklist

Quarry Name:	-	-	-	-	-	-
Producer:						
Producer ID:			Quarry #:			
County:			1/4 Section:			
Legal Description						
When you arrive at the quarry, sign-in at the Scale House.						
Bring Your:						
						Mine Safety and Hazard Training Certification
						Mine Safety Yearly Individual Safety Checklist



11

Form 652 ⁽³⁾

PPE	Equipment	Sampling Aids	Paperwork	Tools
Vest	Cell Phone	Buckets	Quarry Report	Shovel
Hardhat	Camera	Paint Cans	Field Book, Pencil	Hammer
Safety Shoes	GPS unit	Sample Bags	Lab Sample Sheets	Pick
Safety Glasses	Survey Rod	Tags, Marker	Lab Forms	Pry Bar
Hearing Protection	Screens	Wire to tie sacks	Specifications	Sampling Tube
Mask-silica Dust	Splitter	100 ft. tape	Part V, Const. Man	Sledge hammer
Water	Tire chocks	6 ft. tape		



12

Site Visit	Remarks
Quarry Monitor:	
Date:	
Weather:	
Latitude:	
Longitude:	
Ledge/Beds:	
Ledge Thickness:	
Direction Worked:	
Last OFQ SID:	
Current SID:	
Last MRC Lab #:	
Product Being Sampled:	
Largest Screen Size for Product:	
Number of Bags Collected:	
Tests to be run:	
Processing Details:	
Crusher Types:	
Primary:	
Secondary:	
Tertiary:	
Other:	
Scalping Process:	
Stockpiles:	
Number:	
Approximate size of stockpiles (tons):	
Average Output during sampling (tons/hour):	

13

Tracking Production

- Tracking production through sampling and monitoring changes in production are critical to document.
- Changes in production should be documented in the Form 652 or other approved methods from DME.
- Production plans should be updated if significant changes have been made.
- New samples should be taken when a significant change in production is made.
- In addition, when ledges show significant changes in materials, documentation should be made and new samples should be taken to determine if changes in quality occurred.



14

Tracking Production (2)

- Production can be documented as a simple drawing of a flow chart of the process.

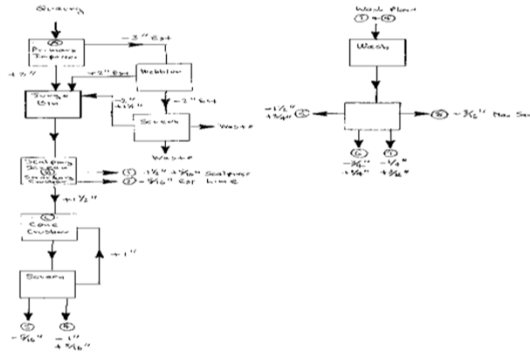

15

Aggregate Sampling (2)

- Questions?



16

OGCA Aggregate Sampling

OGCA = On Grade Concrete Aggregate



1

OGCA Aggregate Sampling ⁽²⁾

Why is this aggregate treated differently?

- History of aggregate related distress in concrete pavement at KDOT.
- OGCA aggregate is tested differently than all other aggregates.
- Must meet much more stringent requirements and is placed onto a prequalified list.



2

Sample Size

Construction Manual Part V Section 5.5 – 2.1



3

Sample Size

2.1.4. On Grade Concrete Aggregates

Material	Sample Size
Ledge Sample	300 lbs (135 kg) per bed, hand-picked from the ledge.
Production Samples	80 lbs (35 kg) of material passing the 3/4" (19.0 mm) sieve and retained on the 1/2" (12.5 mm) sieve.
	80 lbs (35 kg) of material passing the 1/2" (12.5 mm) sieve and retained on the 3/8" (9.5 mm) sieve.



4



LIST OF FREEZE/THAW RESISTANT COARSE AGGREGATE SOURCES FOR ON-GRADE CONCRETE (OGCA LIST)
[2015 – SS 1116] (07-11004-R*)

PQL – 3.4

REVISED – 03/24/21

NOTE: At the time of use on the project, a current Official Quality for the specific beds listed must be on record, the date of "LAST TEST" must be within the preceding 18 months, and the date of "LAST INSPECTION" (where applicable) must be within the preceding 24 months. Contractors and producers are responsible to have test and inspection dates that meet these requirements.

SOURCES INSIDE THE STATE OF KANSAS										
COUNTY	QUARRY NUMBER	PRODUCER	LOCATION (LEGAL DESCRIPTION)			GEOCLASS	BEDS	LAST COMPLETED QPS	LAST INSPECTION	
Allen	4-001-01-LS	Nelson Quarries, Inc. CMS #00800101	SW ¼	S33	T24S	R19E	RYTN	1, 2, 3, 4	03/2021	7/2020
Anderson	4-002-01-LS	Whitaker Aggregate CMS #00847203	SE ¼	S36	T19S	R19E	STNR	1	09/2019	03/2017
Chautauqua	4-010-02-LS	Harshman Construction CMS #00801515	NE ¼	S20	T34S	R11E	PLSM	1, 2, 3, 4	03/2021	02/2020
Clark	6-013-01-DO	Ashland Aggregate, Inc. Ford Sand & Gravel CMS #00849301	SE ¼ of NE ¼	S28	T32S	R23W	SCRL	1	05/2019	04/2018
Elk	4-025-05-LS	Harshman Construction CMS #00801517	NW ¼	S04	T30S	R11E	EVCK	2, 3, 4	02/2021	05/2020
Elk	4-025-06-LS	Mid-States Materials CMS # 00843511	NW ¼	S10	T31S	R08E	BNNT	1	07/2020	11/2019
Franklin	4-030-05-LS	Penny's Aggregate Co. CMS# 00800309	SE ¼	S23	T16S	R20E	STNR	1, 2, 3, 4	02/2021	10/2015
Finney	6-028-02-SG	Klotz Sand and Gravel CMS #00812605	SW ¼	S31	T24S	R31W	N/A	Pit	01/2020	N/A
Finney	6-028-03-SG	Huber Sand Co CMS #00812701	S ½	S21	T24S	R32W	N/A	Pit	02/2020	N/A
Ford	6-029-01-SG	Croell, Inc. CMS # 00813102	NW ¼ & E ½	S32	T26S	R25W	N/A	Pit	05/2020	N/A
Ford	6-029-02-SG	Croell, Inc. CMS #00813401	NE ¼	S20	T26S	R26W	N/A	Pit	05/2020	N/A
Ford	6-029-05-SG	Hard Rock S & G CMS #00844503		S30	T26S	R25W	N/A	Pit	02/2019	N/A

5

[Kansas Geological Abbreviations for Classification of Ledges](#)

NOTE: 1, 2 = Remapped Beds

QUARRY NUMBER SUFFIX DESCRIPTIONS:

NON-CALCAREOUS STONE
 CC – CALCITE-CEMENTED SANDSTONE
 CG – CRUSHED GRAVEL
 GR – GRANITE
 NS – NEPHELINE SYENITE
 SG – SAND/GRAVEL
 SQ – SIOUX QUARTZITE
 RY – RHYOLITE

CALCAREOUS STONE
 DO – DOLOMITE
 LS – LIMESTONE

GEOCLASS DESCRIPTIONS:

BNNT – BENNET REEF LIMESTONE
 BLM – BURLINGAME LIMESTONE
 COCA – COOPER-CALLAWAY LIMESTONE
 DKOT – DAKOTA SANDSTONE
 EVCK – ERVINE CREEK LIMESTONE
 PLSM – PLATTSMOUTH LIMESTONE

ROYER – ROYER DOLOMITE
 RYTN – RAYTOWN LIMESTONE
 STNR – STONER LIMESTONE
 SCRL – STONE CORRAL FORMATION
 TRKO – TARKIO LIMESTONE
 WKRS – WAKARUSA LIMESTONE
 WRLD – WORLAND LIMESTONE

6

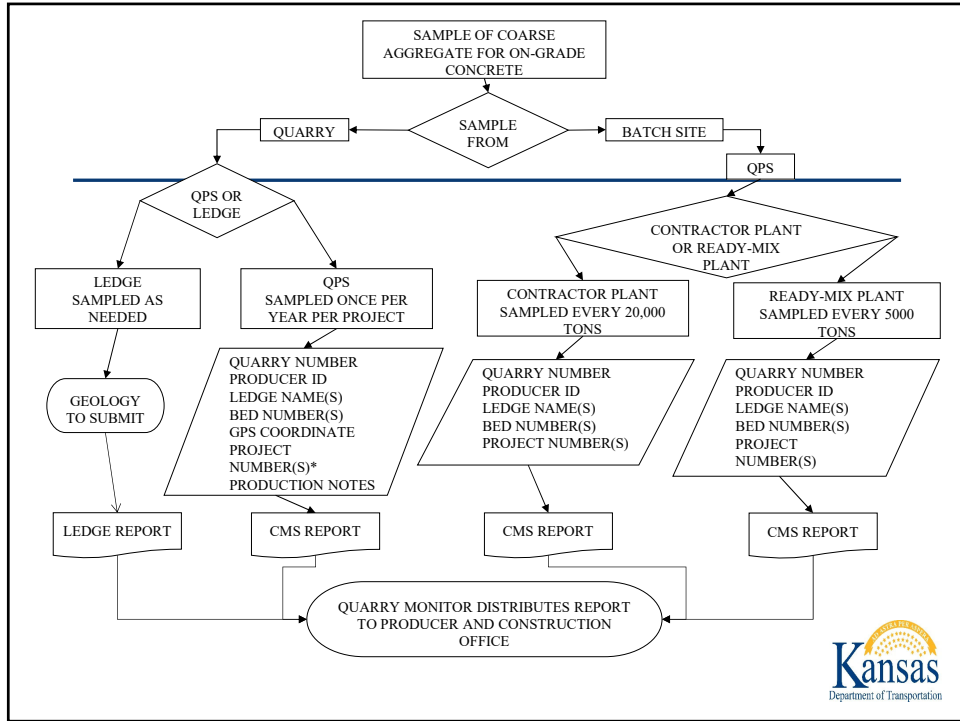

7

Sampling OGCA Aggregates

- Follow procedures in KT-01 in Part V of the Construction Manual.



8

Sampling OGCA

- Ledge sampling is done during a quarry inspection by a Geologist. The geologist will provide guidance during the sampling.



9

Sampling OGCA

- Ledge sampling is done during a quarry inspection by a Geologist. The geologist will provide guidance during the sampling.



10



AGGREGATE TESTING



1

Official Qualities

Specific Gravity and Absorption (KT-06)

LA Wear (AASHTO T-96)

Micro Deval (AASHTO T-327)

Mortar Strength* (KTMR-26)

Soundness (KTMR-21)

**Not regularly performed*



2

Specific Gravity and Absorption of Aggregate



Coarse Aggregate



Fine Aggregate



3

Specific Gravity and Absorption of Aggregate ⁽²⁾

Procedure I

-1" + #4

Prep Weight = 5000g

Finish Weight = 4500g

Procedure II

-#4 + #100

Prep Weight = 1500g

Finish Weight = 500g

KT-06 Procedure:

Oven dry the sample and weigh. A

Soak the sample, dry to SSD condition and weigh. B

Immerse the sample and weigh. C

Bulk = $A/(B-C)$ SSD = $B/(B-C)$ App = $A/(A-C)$ Abs = $100(B-A)/A$



4

Resistance to Degradation of Small-Size Aggregate by Abrasion and Impact in the Los Angeles Machine



5

Resistance to Degradation of Small-Size Aggregate by Abrasion and Impact in the Los Angeles Machine ⁽²⁾

Prep Weights					Finish Weights				
Grading	A (12)	B (11)	C (8)	D (6)	Grading	A (12)	B (11)	C (8)	D (6)
-1.5 +1	1500				-1.5 +1	1250			
-1 +3/4	1500				-1 +3/4	1250			
-3/4 +1/2	1500	3000			-3/4 +1/2	1250	2500		
-1/2 +3/8	1500	3000			-1/2 +3/8	1250	2500		
-3/8 +1/4			3000		-3/8 +1/4			2500	
-1/4 +#4			3000		-1/4 +#4			2500	
-#4 +#8				6000	-#4 +#8				5000

Procedure: Place sample in machine and rotate 500 times at 30 to 33 rpm. Sieve over #12 and report percent loss.



6

Resistance of Coarse Aggregate to Degradation by Abrasion in the Micro-Deval Apparatus



7

Resistance of Coarse Aggregate to Degradation by Abrasion in the Micro-Deval Apparatus ⁽²⁾

Prep Weights				Finish Weights			
Grading	I	II	III	Grading	I	II	III
-3/4 +5/8	600			-3/4 +5/8	375		
-5/8 +1/2	600			-5/8 +1/2	375		
-1/2 +3/8	1200	1200		-1/2 +3/8	750	750	
-3/8 +1/4		600	1200	-3/8 +1/4		375	750
-1/4 +#4		600	1200	-1/4 +#4		375	750
				Time (min)	120	105	95

Procedure: Soak sample in jar for 1 hr then add 5000g of 9.5mm diameter steel shot. Place in machine and rotate at 100 rpm for time specified in chart above. Sieve over #4 superimposed on #16 discarding material finer than #16. Report percent loss.



8

Compressive Strength of Hydraulic Cement Mortar

Performed as needed for aggregates that are **too fine for soundness testing** (sands).

Requires 1500g of -3/8" SSD aggregate

Procedure:

Using Type III cement, make one set of mortar cubes with test aggregate and one set with standard 20-30 (Ottawa) sand.

Determine average compressive strength of test mortar and reference mortar.

Mortar strength ratio =
 $\frac{\text{strength of test mortar}}{\text{strength of reference mortar}}$



9

Soundness of Aggregates by Freezing and Thawing

Soundness for Official Qualities
 Prep Weight SSD – Crushed Aggregate

Grading	I	II	III
-1 +3/4	2250	0	0
-3/4 +3/8	1750	3500	0
-3/8 +#4	500	1000	4000
-#4 +#8	500	500	1000

Finish Weight SSD: (5000g total)



10

Soundness of Aggregates by Freezing and Thawing ⁽²⁾

For Sand, Sand-Gravel, 5000g of "as received material" -1" + #8

Procedure:

Saturate the sample by soaking.

Freeze in air (-20° to 0°F) for no less than 2 hours.

Thaw submersed (70° to 80°F) for 40 minutes.

After 25 cycles sieve as follows:

Modified – Oven Dry Material – 1/2" and 3/8"

OFQ – SSD Material – 1", 3/4", 3/8", #4, & #8

Loss Ratio (LR) =
$$\frac{\text{final sum of cumulative \% retained}}{\text{initial sum of cumulative \% retained}}$$



11

Soundness of Aggregates by Freezing and Thawing ⁽³⁾



12

Soundness of Aggregates by Freezing and Thawing ⁽⁴⁾



13

Soundness of Aggregates by Freezing and Thawing ⁽⁵⁾



14

Other Aggregate Tests

Gradation (KT-02)
Loss by Wash (KT-03)
Organic Impurities (AASHTO T-21)
Acid Insoluble Residue^{1*} (KTMR-28)
Concrete Wetting and Drying² (KTMR-23)
Deleterious Substances (KT-7, KT-8, KT-35)
Concrete Freeze and Thaw¹ (KTMR-22, ASTM C666)

¹For siliceous concrete aggregates on grade. (OGCA Aggregates)

*AI for others as requested.

²For mixed aggregates for concrete. (Really for any siliceous aggregates – might see more of this on coarse aggregates as a result of specs that prohibit limestone.)



15

Wetting and Drying Test of Sand and Sand-Gravel Aggregate for Concrete

KTMR-23 WETTING AND DRYING TEST OF SAND AND SAND-GRAVEL AGGREGATE FOR CONCRETE

a. SCOPE

This test shall be used to determine the acceptability of sand and sand-gravel aggregate to be used in concrete construction, both pavement and structural.



16

Wetting and Drying Test of Sand and Sand-Gravel Aggregate for Concrete ⁽²⁾



17

Wetting and Drying Test of Sand and Sand-Gravel Aggregate for Concrete ⁽³⁾



18

Wetting and Drying Test of Sand and Sand-Gravel Aggregate for Concrete ⁽⁴⁾

Concrete Modulus of Rupture:

- At 60 days, minimum.....550 psi
- At 365 days, minimum....550 psi

Expansion:

- At 180 days, maximum...0.050%
- At 365 days, maximum...0.070%



19

Resistance of Concrete to Rapid Freezing and Thawing KTMR-22 (The 660 test) Durability Test

KTMR-22 Resistance of Concrete to Rapid Freezing and Thawing

a. SCOPE

This test shall be used to determine the acceptability of coarse aggregate to be used in concrete construction, both pavement.

This is a pass-fail test only for the concrete coarse aggregate.



20

Resistance of Concrete to Rapid Freezing and Thawing KTMR-22 (The 660 test) Durability Test ⁽²⁾



Similar to ASTM C666 with some modifications

- 90-day cure
- 2-day tempering
- 660 cycles of F&T
- Only change in mixes is the coarse aggregate
- Cement, admixture, water, sand are all the same for every mix.



21

Resistance of Concrete to Rapid Freezing and Thawing KTMR-22 (The 660 test) Durability Test ⁽³⁾



22

Resistance of Concrete to Rapid Freezing and Thawing

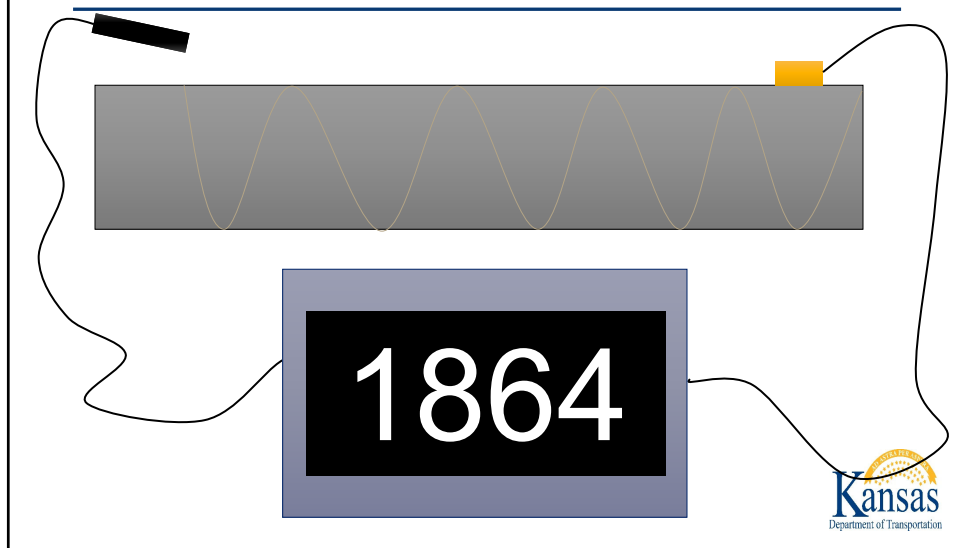

23

Resistance of Concrete to Rapid Freezing and Thawing ⁽²⁾

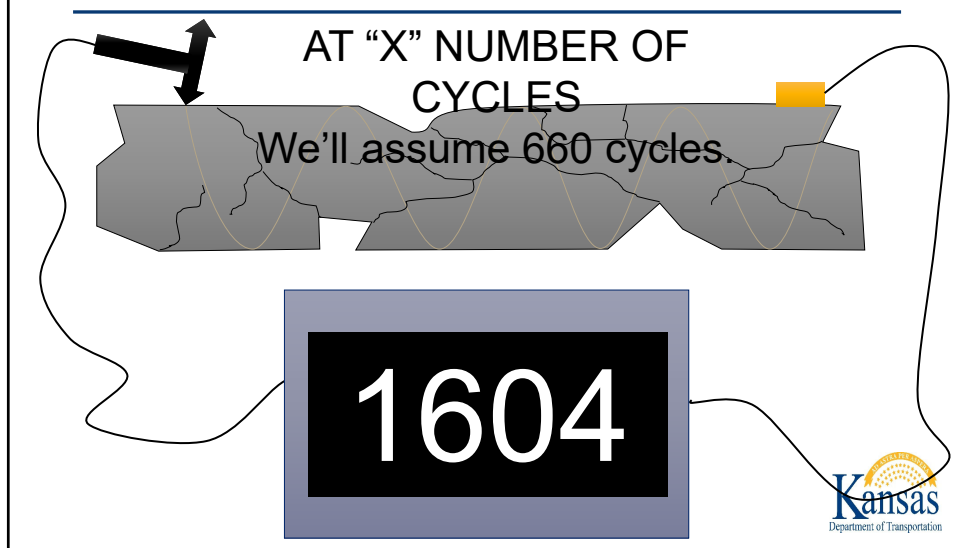

24

Why do we run these tests? To be sure the aggregates meets a minimum quality prior to utilizing it in projects.

- **Specific Gravity** – KT-06 – mix designs are based on volume; we must know the volume of the material to determine how much is needed in a mixture of the materials.
- **LA Wear** – Develop back in the 1930's, in, you guessed it = Los Angeles. It is not directly correlated to field performance but has been a good indicator of the quality of the aggregate in terms of abrasion resistance and many DOT's have a long history utilizing this test.
- **Micro-Deval** – Very similar to LA Wear and is much newer of a test. Was a potential for replacement of LA Wear but does not correlate with the data. KDOT utilizes this test method in at least one specification.
- **Soundness** – Another quality test to determine an aggregates potential to resist freeze and thaw conditions.
- **Mortar Strength** – As previously stated, alternative to Soundness when we do not have a large enough material to run Soundness.



25

Questions?



26

AGGREGATE DURABILITY



1



Outline

- Causes of Concrete Failures
- Aggregate-Related Distress in Kansas
 - Alkali-Silica Reaction (ASR)
 - D-Cracking
- 1. What are they and why are they important?
- 2. How do they work?
- 3. How can damage be prevented?

2

History of KDOT “Durability”

- 1930 – 1942 Alkali Silica Reaction
- 1960 – 1980 “D-Cracking”
- 1990’s – Centerline Deterioration
- 2008 – Permeability Requirements

3

KDOT FACT

- Between 1960 - 1980 over 60% of the PCCP placed in Kansas was either overlaid or replaced within 10 years.



4

Kansas What causes concrete “failures?”

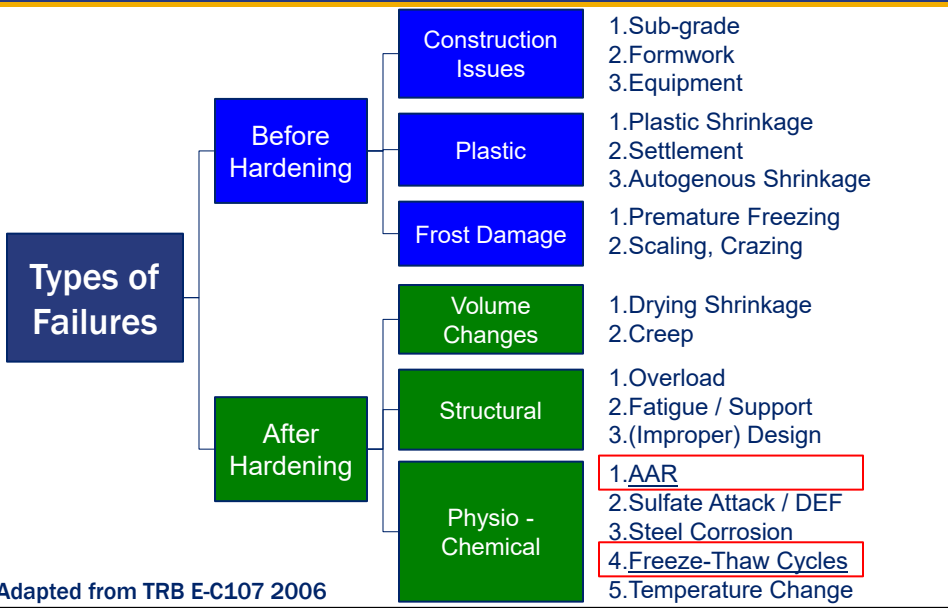

5

Kansas D-Cracking (Durability Cracking)

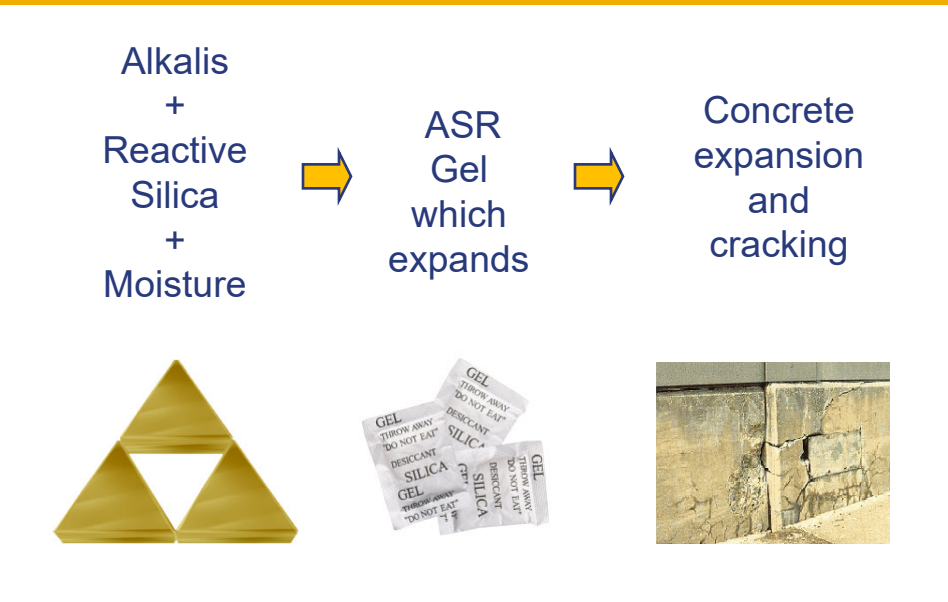

6

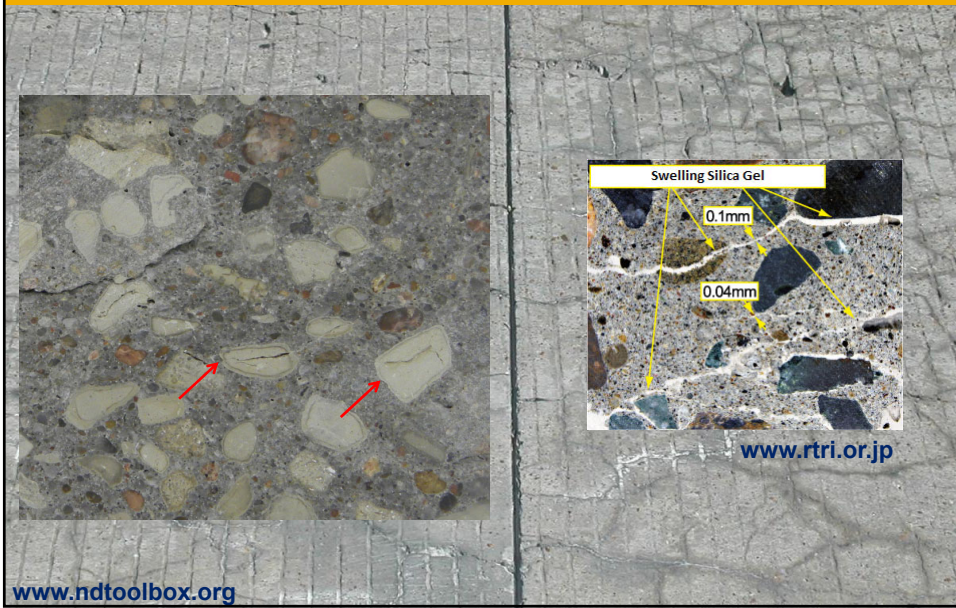

7



AASHTO Innovative Highway Technologies



AASHTO Innovative Highway Technologies

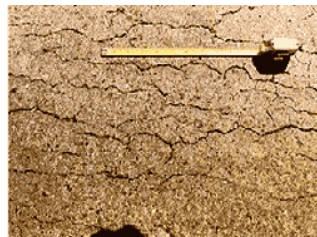

AASHTO Innovative Highway Technologies



Georgia Tech School of CEE - Courtney Collins

8

Reactants: alkalis, reactive silica, water

Alkalis (soluble bases):

Main Cations: Sodium (Na⁺)
Potassium (K⁺)

Common Sources: Portland Cement
Deicing Agents
Seawater & Deicing Salts
SCMs and Aggregate

3	Li
6.941	
11	Na
22.990	
19	K
39.098	
37	Rb
85.468	
55	Cs
132.91	
87	Fr
(223)	

Reactants: alkalis, reactive silica, water

Reactive Silicas (SiO₄⁻⁴):

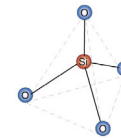

Amorphous Silica

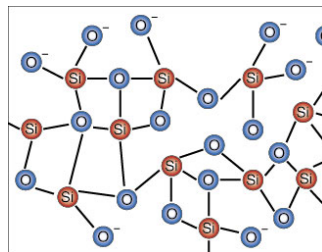

Crystalline Silica

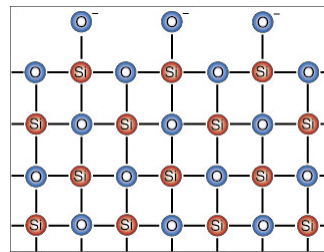

Georgia Tech School of CEE - Courtney Collins

Reactants: **alkalis**, **reactive silica**, **water**

Water:

Found in pore spaces in concrete

1. Addition of water to concrete mixes
2. Moist environment/permeable concrete

Reactive silica attacked by OH⁻

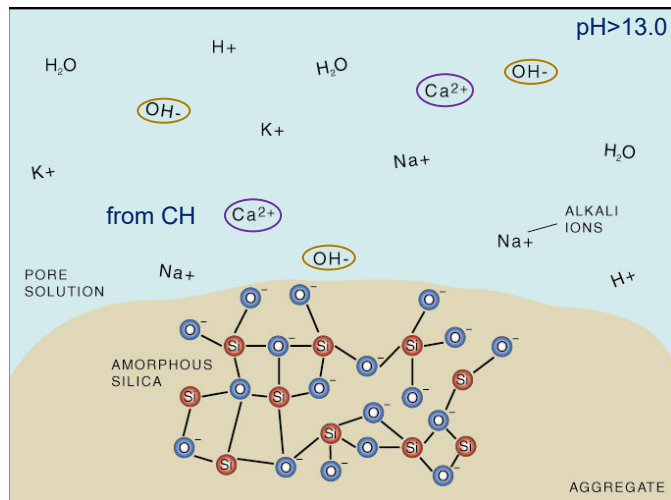

Creation of Alkali-Silica Gel

1. Silica broken down by OH^-
(and H_2O , Na^+ , K^+ , CH , H_3SiO_4^-)
2. pH drops (**more acidic**), dissolves CH
3. Na^+ (K^+) and Ca^{2+} diffuse into aggregate

Forms C-N(K)-S-H gel, non-swelling high viscosity

All by itself, no problem.

13

Creation of Alkali-Silica Gel

4. If less silica is available (**less H_3SiO_4^-**)
5. Solubility of CH is depressed

Forms N(K)-S-H gel, swelling low viscosity

All by itself, no problem.

14

$N(K)-S-H + C-N(K)-S-H = \text{big problem}$

Composite high swelling, low viscosity

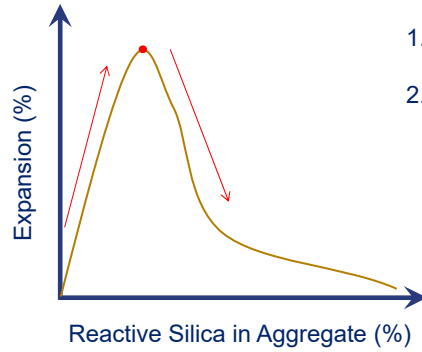

1. pH drops begins producing C-N(K)-S-H
2. More Ca⁺ produced, less N(K)-S-H gel produced

Alkali-silica gel takes in water, expands, and cracks concrete

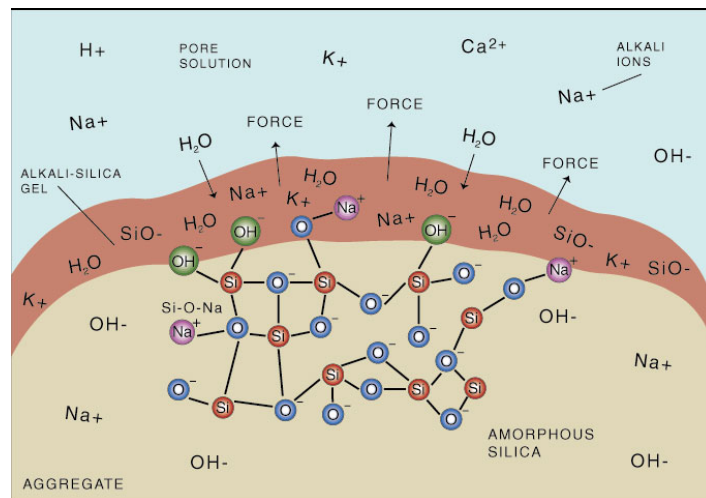

Map Cracking results when the cracks reach the surface. The presence of gel and staining is also common.



Georgia Tech School of CEE - Courtney Collins

17

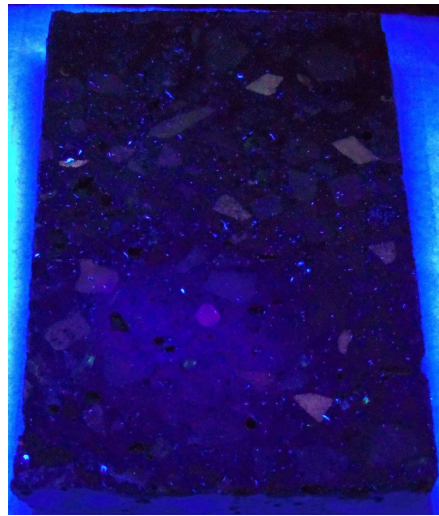
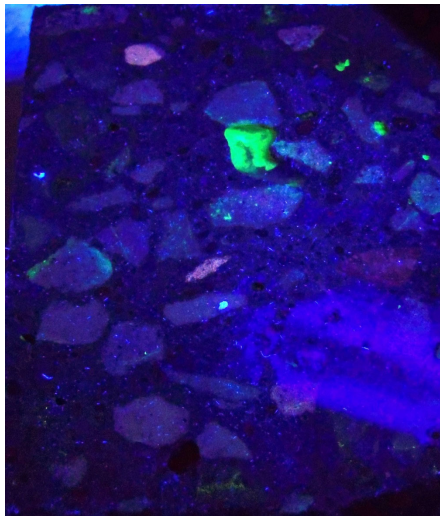

18



How can damage be prevented?

Limit Reactive Aggregate or Available Alkalis

1. Use aggregate that passes KDOT's Wetting and Drying Test – PQL 3.1
2. Limit the amount of reactive aggregate – Sweetener – Division 1100

Type of Coarse Aggregate Sweetener	Proportion Required by Percent Weight
Crushed Sandstone*	40 (minimum)
Crushed Limestone or Dolomite*	40 (minimum)
Siliceous Aggregates meeting subsection 1116.2a.(2)	40 (minimum)
Siliceous Aggregates not meeting subsection 1116.2a.(2) **	30 (maximum)

19



How can damage be prevented?

(2)

Limit Reactive Aggregate or Available Alkalis

1. Replace a portion of the cement (reduce alkalis) with SCMs (*i.e.*, fly ash, slag)
2. Retest with ASTM C1567 (16 days)

20

- Freeze-thaw damage of coarse aggregate in concrete
- Characteristic deterioration pattern
- Specifically related to the coarse aggregate
- Currently, no good indicator tests other than making F/T beams – PQL 3.4

21

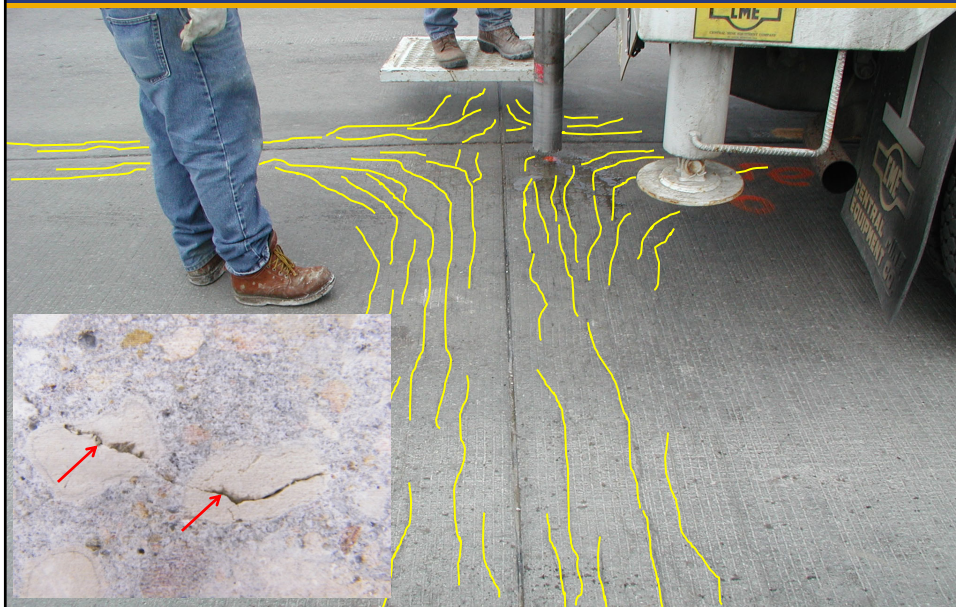

22



23

1. Do not use lower quality aggregate
2. Limit the maximum size of coarse aggregate

24

1. Alkali-Silica Reaction (ASR) requires alkalis, water, and reactive silica
2. Limit any of these three to prevent damage
3. D-Cracking is freeze-thaw damage in aggregate
4. Use a high-quality freeze-thaw durable aggregate to prevent damage

Quarry Monitor CIT Class

CMS - AWP



1

Questions?



2

Communication

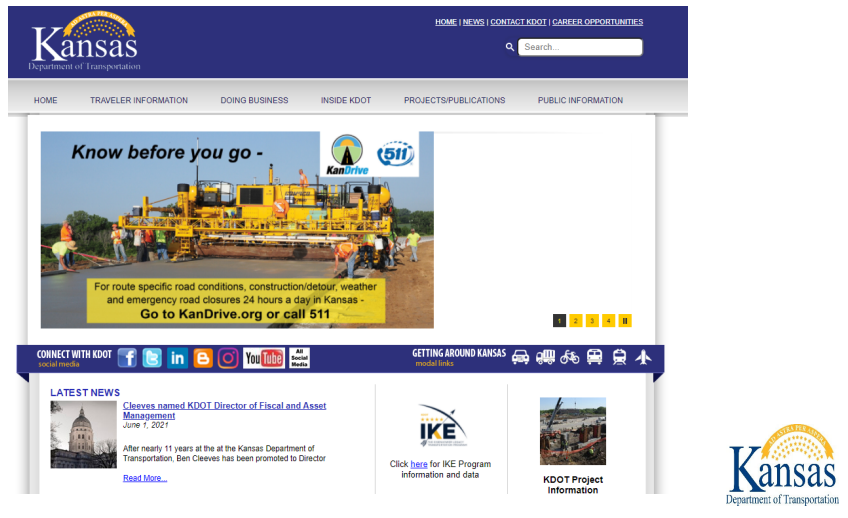

1

Communication ⁽²⁾

Most results and information is found through link on the KDOT website. Navigate to the "Doing Business" site and select "Highway Contractors"

- OFQ Results
 - http://kdotapp.ksdot.org/ofq/internet_ofq_query.cgi
- PQL's (the 3's)

3. Aggregates

- 3.1 [List of Non-Reactive Siliceous Aggregate Sources for Concrete \(Wetting & Drying List\)](#) - (03/24/21)
- 3.2 [Lightweight Aggregate For Concrete \(Modified Lightweight Aggregate\)](#) - (06/24/20)
- 3.3 [Lightweight Aggregate For Cover Material](#) - (01/22/21)
- 3.4 [Aggregate Sources for On-Grade Concrete](#) - (05/24/21)
- 3.5 [Aggregate Sources for RIP RAP and Ditch Liner](#) - (05/24/21)
- 3.6 [Aggregate Sources for Polymer Concrete Overlay & High Friction Surface](#) - (01/08/21)



2

Communication (3)

Web links on KDOT website

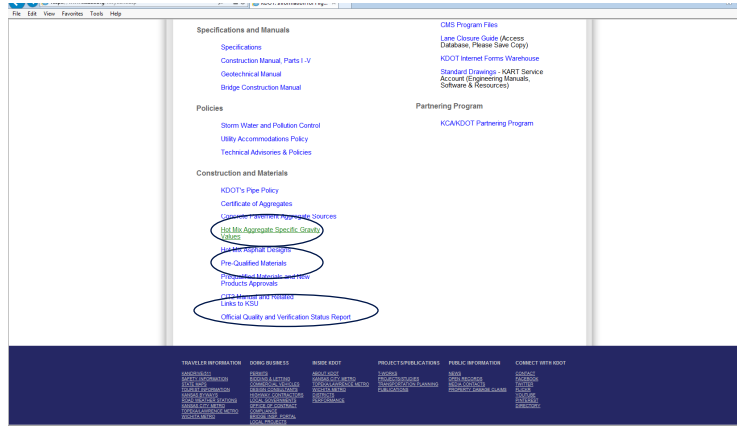

3

Communication (4)

Pre-Qualified Lists

LIST OF FREEZE/THAW RESISTANT COARSE AGGREGATE SOURCES FOR ON-GRADE CONCRETE (OGCA LIST) [2015 - SS 1116] (07-11004-R*)
PQL - 3.4 **REVISED - 05/24/21**

NOTE: At the time of use on the project, a current Official Quality for the specific beds listed must be on record, the date of "LAST TEST" must be within the preceding 18 months, and the date of "LAST INSPECTION" (where applicable) must be within the preceding 24 months. Contractors and producers are responsible to have test and inspection dates that meet these requirements.

SOURCES INSIDE THE STATE OF KANSAS									
COUNTY	QUARRY NUMBER	PRODUCER	LOCATION (LEGAL DESCRIPTION)	GEOCLASS	BEDS	LAST COMPLETED GPS	LAST INSPECTION		
Allen	4-001-01-L5	Nelson Quarries, Inc. CMS #0080301	SW ¼	S33 T24S R19E	RYTN	1, 2, 3, 4	03/2021	7/2020	
Anderson	4-002-01-L5	Whitaker Aggregate CMS #0081703	SE ¼	S36 T19S R19E	STNR	1	08/2019	03/2017	
Chautauque	4-010-02-L5	Hartman Construction CMS #0081515	NE ¼	S20 T34S R11E	PLSM	1, 2, 3, 4	03/2021	02/2020	
Clark	6-013-01-00	Ashland Aggregate, Inc. Ford Sand & Gravel CMS #0084301	SE ¼ of NE ¼	S28 T32S R23W	SCRLL	1	05/2019	04/2018	
Elk	4-025-05-L3	Hartman Construction CMS #0081517	NW ¼	S04 T30S R11E	EVCK	2, 3, 4	03/2021	05/2020	
Elk	4-025-06-L3	Mid States Materials CMS #0084311	NW ¼	S10 T31S R08E	BNNT	1	07/2020	11/2019	
Finney	6-028-02-S0	Kintz Sand and Gravel CMS #0081205	SW ¼	S31 T24S R31W	N/A	PH	01/2020	N/A	
Finney	6-028-03-S0	Huber Sand Co. CMS #0081201	S ½	S21 T24S R32W	N/A	PH	03/2020	N/A	
Finney	6-028-05-S0	Huber Sand Co. CMS #0081204	NE ¼-SW ¼	S22 T24S	R26W	N/A	PH	04/2021	N/A
Ford	6-029-01-S0	Cook, Inc. CMS #0081302	NW ¼, E ½	S32 T26S	R26W	N/A	PH	05/2020	N/A
Ford	6-029-02-S0	Cook, Inc. CMS #00813401	NE ¼	S20 T26S	R26W	N/A	PH	05/2020	N/A
Ford	6-029-05-S0	Hard Rock S & G CMS #0084403		S30 T26S	R26W	N/A	PH	02/2019	N/A

PQL - 3.4

Revised 05/24/21

Page 1 of 4



4

Communication ⁽⁵⁾

Official Quality and Status Report

File Edit View Favorites Tools Help

Official Quality Status by Quarry

This list represents the latest OFQ completed for each producer listed. Note that the producer may have submitted several samples for OFQ depending on production techniques. Please click on the producer ID link in the first column to see a list of tests performed for a particular producer. KDOT assumes no liability or responsibility for any errors or omissions.

Show All

Prod ID	Name	Legal	County	Last Cmpl
0000790	CENTRAL PLAINS CEMENT (SUGAR CREEK,MO)		Not in KS	2015
0000771	MONARCH CEMENT CO. (HAMBOLDT,KS PLANT)		Allen	2014
0001893	ARNCO STEEL CO (HEKETT),KANSAS CITY,MO)		Not in KS	2002
0001940	SHAWNEE ROCK (PLANT #3),LOONE ELM QUARRY)	503T145R23E	Johnson	2002
0010131	CHANDLER MATERIAL CO (TULSA,OK)		Not in KS	2011
0010231	RALPH BOBBITT (BEAVER CO,OK)	502T030R21E	Not in KS	2001
0010230	PECTHOLIC CORP (COWLEY CO)	520T055000W	Leeward	2004
0010231	WILLBMAN PIT (MORTON COUNTY) SW 1/4	500T225R20W	Morton	2004
0013010	HECKETT MULTISERV (MUSCATINE, IA)		Not in KS	2007
0014281	CAPITAL SAND COMPANY (JEFFERSON CITY,MO)	500T40N11W	Not in KS	2010
0014301	BEMAS CONSTRUCTION (ENGLWOOD, CO)		Not in KS	2011
0014302	BEMAS CONSTRUCTION (RILEY CO) SW 1/4	507T115R07E	Riley	2012
0014381	BLEVINS CHAT COOP(SMEEER FILE),PESHER,OK)	525T20R22E	Not in KS	2014
0014401	JASPER STONE, LLC (JASPER, MO) (E1/2)	513T30N31W	Not in KS	2014
0015001	NICK QUARRIES (SMITH CENTER, KS) NE 1/4	527T015R14W	Smith	2014
0015891	EARTH WORK SOLUTIONS(COLORADO SPRINGS,CO)		Not in KS	2013
0000007	LAFARGE CORP (MENEFEE LOC),PETTIS CO,MO)	523T40R22W	Not in KS	2002
0000008	LAFARGE CORP(UNDERGROUND),JACKSON CO,MO)	513T50N32W	Not in KS	2011
0000009	MCKENSON CONCRETE (EAST BLANET),MIW1/4	524T105R10W	McPherson	2015



5

Communication ⁽⁶⁾

Specific Gravity (SpG) List

HOT MIX AGGREGATE SPECIFIC GRAVITY VALUES

This site provides aggregate specific gravity values for contractors to use to calculate the VMA for hot mix designs for projects in each letting. This procedure is being used to reduce some of the risks associated with bidding projects in the letting. Actual specific gravity values of the individual aggregates used on the projects should be determined as part of the mix design review process. Changes in geology, processing, location, test procedures, and the passing of time may cause changes in the specific gravity. KDOT will honor, as a minimum value, only those specific gravities in black print. The values in red print at the end of each list have not been verified within the required timeframes. They are for information only and the specific gravities must be verified before the aggregates are used on any KDOT projects. The specific gravity values for the aggregates shown in red may be adjusted up or down by the districts to reflect the results of their tests.

Note: If no list is shown for the current month, use the previous month's list.

Monthly Hot Mix Aggregate Specific Gravity Values

May 21	December 20	December 19	December 18
April 21	November 20	November 19	November 18
March 21	October 20	October 19	October 18
February 21	September 20	September 19	September 18
January 21	August 20	August 19	August 18
	July 20	July 19	July 18
	June 20	June 19	June 18
	May 20	May 19	May 18
	April 20	April 19	April 18
	March 20	March 19	March 18
	February 20	February 19	February 18



6

July 2021 LETTING PROCEDURE SPECIFIC GRAVITIES												
Producer	CMS ID	Legal Description	Location	Products	Bulk Dry (Gals)	Saturated Surf Dry	Apparent	Percent Absorb	Date Modified or Verified	Chat or SSG	Latitude	Longitude
Altop	811105	S27 T055 R03W	Cloud Co.		2,539	2,563	2,603	1.0	August 1, 2020	s		
Altop	811107	S27 T135 R01E	Dickinson Co.		2,566	2,611	2,705	2.2	July 1, 2017	s		
Altop	811114	S05 T045 R04W	Republic Co.		2,515	2,559	2,627	1.7	September 1, 2020	s	39.73909	97.78814
American S&G	811116	S08 T155 R02W	Saline Co.		2,541	2,588	2,666	2.3	February 1, 2020	s		
Anchor Stone (WRSW)	836402	S34 T28N R32W	Jasper Co. MO	3/4"	2,486	2,558	2,680	2.9	May 1, 2021		37.10327	94.40710
APAC Kansas	826005	S14 T125 R08W	Lincoln Co.	CS-1	2,604	2,630	2,674	1.0	January 1, 2021			
APAC Kansas	826005	S03 T125 R09W	Jones Co.		2,500	2,525	2,581	1.4	April 1, 2021			
APAC-Shears	826001	S11 T125 R08W	Lincoln Co.	CS-1	2,503	2,556	2,642	2.1	July 1, 2021			
APAC-Shears	801834	S21 T235 R05W	Reno Co.		2,560	2,583	2,633	0.9	December 1, 2020	s		
APAC-Shears (HRFD)	801935	S02 T215 R13E	Coffey Co.		2,570	2,626	2,725	2.2	October 1, 2020			
Ashland Agg	849302	S22 T325 R23W	Clark Co.		2,668	2,704	2,766	1.3	December 1, 2020			
Associated	819905	S14 T26S R01W	Sedgewick County		2,554	2,578	2,618	1.0	October 1, 2018	s		
Bayer Const. Co.	801834	S01 T135 R04E	Dickinson Co.	CS-1	2,403	2,511	2,603	4.5	June 1, 2020			
Bayer Const. Co. (TRKO)	802445	S04 T115 R09E	Riley Co.	3/4" x 1/4"	2,541	2,604	2,716	2.9	October 1, 2020			
Bayer Const. Co. (TRKO)	802445	S04 T115 R09E	Riley Co.	Washed 3/8" Chps	2,480	2,563	2,695	3.3	October 1, 2020			
Bayer Const. Co. (TRKO)	802449	S03 T115 R09E	Riley Co.		2,515	2,584	2,703	2.8	March 1, 2020			
Beathrice S&G	824603	S04 T03N R01W	Thayer Co. NE	SSG	2,569	2,590	2,626	0.8	July 1, 2019	s		
Bayer Crushed Rock Co (BFLS)	806901	S26 T45N R33W	Cass Co. MO	1"	2,502	2,610	2,698	2.0	June 1, 2021			
Blue River Sand	805404	S25 T04S R06E	Marshall Co.		2,559	2,584	2,624	1.0	November 1, 2020	s		
Central Sand	848601	S22 T26S R01W	Sedgewick County	SSG	2,554	2,577	2,620	1.0	December 1, 2018	s		
Concrete Enterprise	813403	S34 T26S R13W	Frank Co.		2,559	2,595	2,641	1.2	November 1, 2018	s		
Cornijo Mix	820103	S23 T26S R01W	Sedgewick Co.	SSG	2,571	2,592	2,625	0.8	August 1, 2020	s		
Cornijo Materials	802244	S23 T26S R11E	Elk Co.	3/4	2,539	2,601	2,709	2.5	August 1, 2020			
Cornijo Stone (EVCK)	801504	S13 T31S R10E	Elk Co.	3/4"	2,511	2,577	2,688	2.7	June 1, 2020		37.35270	96.28578
Deeweese	825001	S17 T01N R07W	Nuckolls Co. NE	SSG	2,576	2,594	2,623	0.7	November 1, 2018	s		
Dodge City Sand	813102	S32 T26S R25W	Ford Co.		2,550	2,580	2,630	1.0	December 1, 2019	s		
Dolene	809402	S32 T06N R15W	Kiowa Co. OK		2,706	2,723	2,753	0.6	June 1, 2020		34.94803	98.81396
Dolene	809405	S31 T06N R15W	Roseville, OK	CS-2	2,727	2,742	2,769	0.6	May 1, 2021			
Sakine Sand	817302	S08 T22S R16W	Palmer Co.		2,574	2,623	2,651	1.1	May 1, 2021	s		
First Rock #5	822506	S20 T29N R23E	Ottawa County, OK	CME	2,550	2,590	2,656	1.6	July 1, 2020	c		
**	822503	SW 1/4 S29 T29N R23E	Ottawa County, OK		2,539	2,587	2,668	1.9	March 1, 2020	c	36.96011	94.84968
Granite Mountain	838701	S26 T01N R12W	Pulaski Co. AR		2,592	2,608	2,633	0.6	October 1, 2020			
Gravel and Concrete	832701	S15 T22S R07W	Reno Co.		2,551	2,580	2,620	1.1	July 1, 2018	s		
Hamm	800976	S15 T14S R04E	Dickinson Co.		2,457	2,541	2,681	3.4	March 1, 2020			
Hamm (ARGN)	803903	S16 T14S R23E	Johnson Co.	CS-1, 3/4", CS-1A, 3/8"	2,575	2,629	2,724	2.1	June 1, 2020			
Hamm (BFLS)	842701	S07 T47N R30W	Dickinson Co. MO	3/4	2,550	2,604	2,696	2.1	November 1, 2020			
Hamm (EVCK)	800977	S09 T11S R17E	Jefferson Co.		2,558	2,622	2,732	2.5	November 1, 2019			
Hamm (FRLY)	803903	S16 T14S R23E	Johnson Co.	3/4"	2,575	2,631	2,728	2.2	October 1, 2020		38.83682	94.86959
Hamm Kansas (FRLY)	803903	S16 T14S R23E	Johnson Co.		2,584	2,631	2,711	1.8	March 1, 2021		38.83518	94.86701
Hamm (FRLYARG)	804008	S07 T16S R25E	Miami Co.	3/4	2,543	2,605	2,718	2.4	December 1, 2020			
Hamm (HRFD)	*	S09 T17S R15E	Decatur Co.		2,537	2,608	2,730	2.8	November 1, 2020			
Hamm (HRFD)	800977	S09 T11S R17E	Jefferson Co.		2,566	2,581	2,703	2.8	July 1, 2020			
Hamm (FRLY)	803705	S10 T14S R23E	Johnson Co.	3/4", 3/16"	2,518	2,605	2,732	1.4	March 1, 2021		38.85231	94.84701
Hamm (NEVA)	800980	S11 T07S R10E	Pottawatomie Co.		2,443	2,529	2,654	3.1	November 1, 2020			
Hamm (STNR)	800907	S15 T13S R21E	Douglas Co.		2,599	2,642	2,719	1.7	December 1, 2019			
Hamm	802457	S10 T14S R04E	Dickinson Co.	CS-1	2,483	2,538	2,663	3.1	April 1, 2021			
Hartman Const. (EVCK)	801517	S04 T30S R11E	Elk Co.	3/8"	2,688	2,637	2,722	1.6	December 1, 2019			

7

Communication ⁽⁷⁾

Geology Inspection Report

MEMO

DATE: November 13, 2015

TO: Sandra L. Tommer, P.E. Chief,
Bureau of Construction and Materials

ATTENTION: Rick Berezinsky, P.E.
District 1 Materials and Construction Engineer

FROM: Kyle Hatterson, P.G.
Topeka Regional Geology Office

SUBJECT: Quarry Lodge Inspection-New Lodge
Hamm Construction
Granville Quarry
Quarry #01-044-04
Section 9, T-11-S, R-17-E
Jefferson County, KS



Bureau of Structures and Geotechnical Services

At the request of Greg Scott with Hamm Construction, the quarry lodges at the above referenced quarry were inspected on July 24, 2015. Hamm would like to produce On-grade Concrete Aggregate (OGCA) from the Irvine Creek, Rock Bluff, and Ozawie Limestone Members. All of the limestone lodges were accessible for inspection. The active lodges are located in the Section 9, T-11-S, R-17-E.

C: Greg Hildner, PE, Topeka Metro Engineer
Mike Heflin, PE, Field Materials Engineer
Lynn Heflin, PE, Field Materials Engineer
Scott Ashwell, CMS Materials Coordinator
Project File
Topeka Regional Geology Office



8

Communication ⁽⁸⁾

Geology Inspection Report

EVALUATION OF QUARRY MATERIAL																	
Homm Construction Grantville Quarry Section 9, T-11-S, R-17-E GPS: N: 39.10340, W: 95.52981 GPS: N: 39.10296, W: 95.53037 GPS: N: 39.10332, W: 95.52959 Jefferson County				TEST RESULTS													
Quarry #01-044-04		Lab #		BED NUMBER	DURABILITY CLASS	RESULT	MEAR	MAG. T. & T	MOD. ADS	SP. GRM. DRY	SP. GRM. WET	A. I.	PVF	IMP. NUMBER	IMP. SYSTEM	DISINTEGRATION FACTOR	CYCLES
Bed 6		1.4'		1													
Shale Seam		1.4'		2													
Ervin Creek Limestone		1.4'		3													
Deer Creek Limestone Formation		1.4'		4													
Upper Pennsylvanian Series		1.4'															
Pennsylvanian Subgroup		1.4'															
On-Grade Concrete Aggregate		1.4'															



9

Communication ⁽⁹⁾

Geology Inspection Report

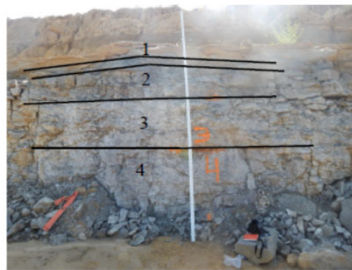

GEOLOGY
 Pennsylvanian Subsystem
 Upper Pennsylvanian Series
 Virgiana Stage
 Deer Creek Limestone Formation
 Ervin Creek Limestone Member
 G.P.S. Location: N: 39.10340, W: 95.52981

Bed #1: Limestone, brown to tan, dull, fine grained, thin bedded, fossiliferous, brachiopods and fusulines, weathered to non-weathered, some iron staining within fractures, very hard Thickness: 1.4 ft.
Bed #2: Limestone, thin bedded, wavy, silty, gray, crystalline, non-weathered, fine to medium grained, occasional thin shale parting, wavy, some discontinuous calcite seams, very hard Thickness: 1.4 ft.
Bed #3: Limestone, gray to dull gray, thin to medium bedded, wavy shale parting throughout, medium to fine grained, silty, fossiliferous Thickness: 1.4 ft.
Bed #4: Limestone, gray, medium grained, medium bedded, fossiliferous, wavy bedded, thin shale seams throughout, non-weathered, very hard. Thickness: 8.9 ft.



10

Communication (10)

- The aggregate lists: OGCA List, HMA SpG List, & Wetting and Drying List do not grant or guarantee approval for use
 - Still need current, approved OFQ
 - OGCA still need latest 2 QPS passing
- Need to make sure imported siliceous aggregates have been tested for ASR (wetting & drying test or ASTM C1260 or C1567)



**KDOT to Utilize Drones/UAV and other
Technology to conduct OGCA
Investigations**



1



2

- KDOT has stepped up its game in improving safety as it has made a concerted effort to reduce risk while conducting quarry inspections across the state.
- Historically a quarry inspection consisted of a KDOT Geologist and a District Quarry Monitor going into an active quarry, describing the characteristics of the rock, and collecting samples to be tested for quality. There are a number of safety factors to consider: truck traffic, stockpile integrity, and falling rocks to name a few. The previously mentioned risks are an inherent part of the job, but we can mitigate some of these risks by having lightbars flashing and building smaller sample piles to sample from. **The one risk that up until this point has been unavoidable is falling rock when characterizing the rock ledge face.** This risk has been identified by KDOT as well the Kansas Aggregate Producers Association (KAPA) as the greatest risk to personnel when conducting quarry inspections.



3

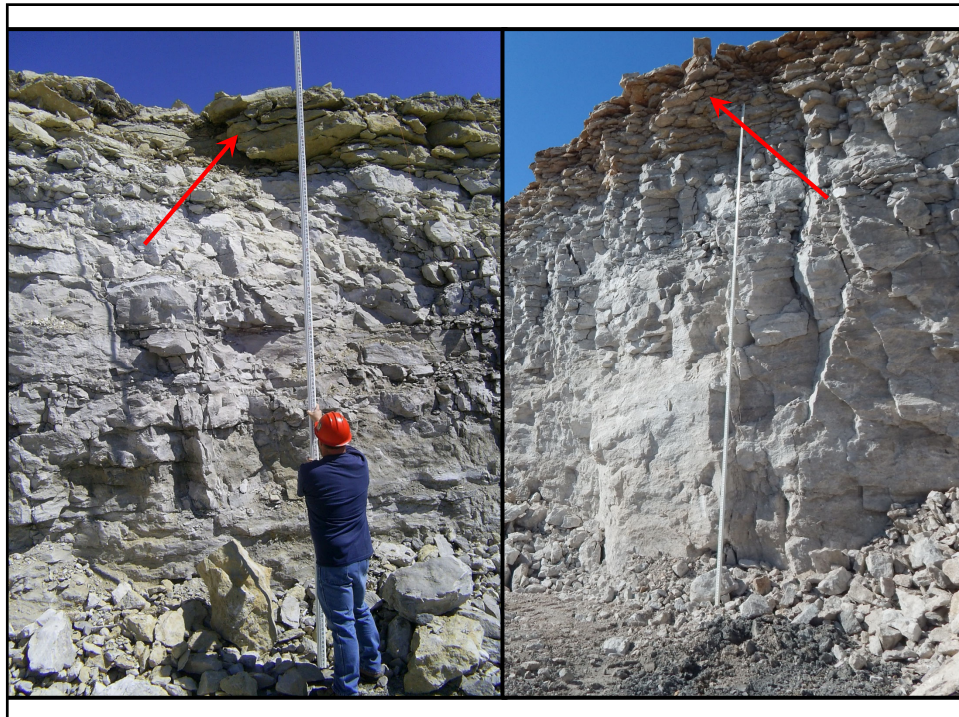

4

As a result, KDOT began to look at alternative ways to get near the ledge face without putting a person in danger, while still being able to characterize the rock.



The solution came in the form of drones/UAV (Unmanned Aerial Vehicle) and LIDAR Scans. This idea initially originated from looking at mountainous states and how they routinely perform rockfall investigations. While those inspections are considerably different the idea of using technology that keeps people a safe distance from a potential hazard is the same.



5

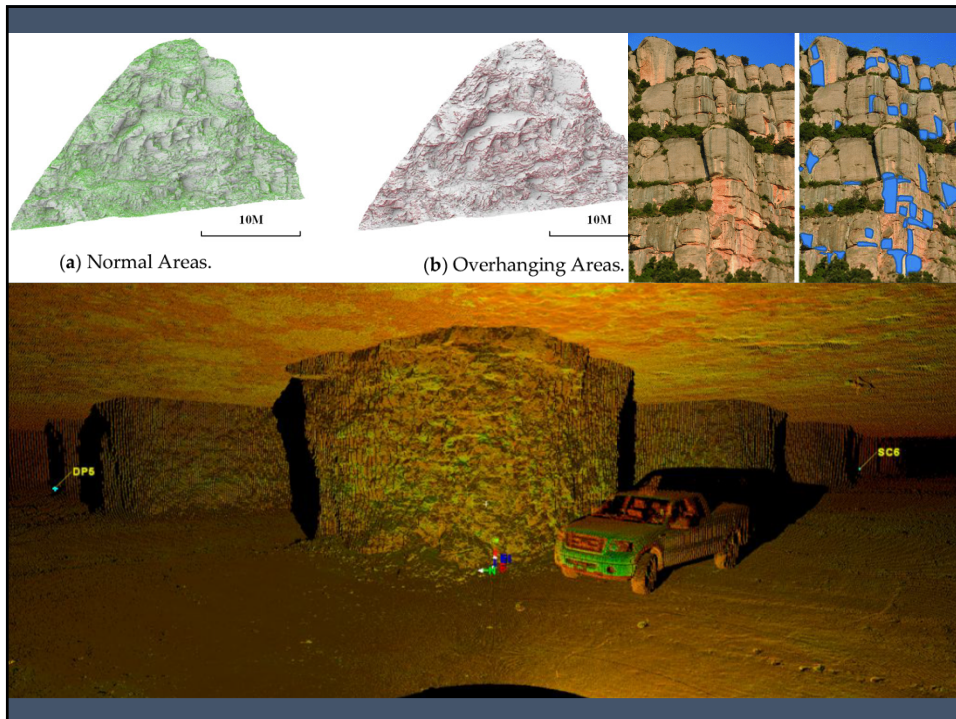

6



• **KDOT In House UAV Pilots**

• In late 2019 and early 2020 KDOT began training in house personnel to become certified drone/UAV pilots. These pilots are not from just one section of KDOT, they are a part of different sections and bureau which leads to a wide variety of backgrounds and expertise. As pilots were being trained and looking for opportunities to fly KDOT started the initial talks to implement using drone technology on quarry inspections. While it was not until late 2020 when the first quarries were done utilizing this technology and the result exceeded expectations. By utilizing a drone/UAV all personnel stayed a safe distance from the ledge while providing clear images of each bed and a high level of accuracy of bed thicknesses.

Utilizing other Technologies

While the drone/UAV inspection exceeded expectations, another technology emerged as another possibility. LIDAR which stands for Light Detection and Ranging, is a remote sensing method that uses light in the form of a pulsed laser to measure ranges.

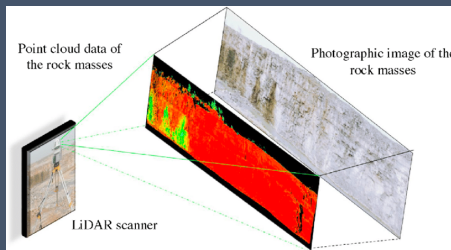

This technology is used predominately by KDOT Survey Section to perform a range of investigations. It was not until some FAA regulation were encountered restricting drone/UAV flights at a quarry location when KDOT Survey suggested using LIDAR technology. The LIDAR scans provided a very detailed image as well as incredibly accurate bed thicknesses.

- **Moving/Flying Forward with this Technology**

- KDOT intends to utilize both drone/UAV and Lidar when conducting OGCA inspections.
- The parameters have not been formally set for when this technology will be used and when it won't.
 - Since the primary goal is safety when utilizing drones and LIDAR, it is a very real possibility that many quarries will not need the assistance of drones and LIDAR.
 - Preliminary talks of when and where have been geared toward site with high ledge faces. i.e., any ledge greater than 6'.



9

How KDOT will use the information collected using drones/UAV and LIDAR

- Currently and for the foreseeable future the only thing the drones and LIDAR will collect are images of the ledges and bed thicknesses.
 - KDOT will provide your quarry information that is collected while using drones and LIDAR upon request.
- KDOT's sole purpose in using this technology is for safety aspects in the inspection process.

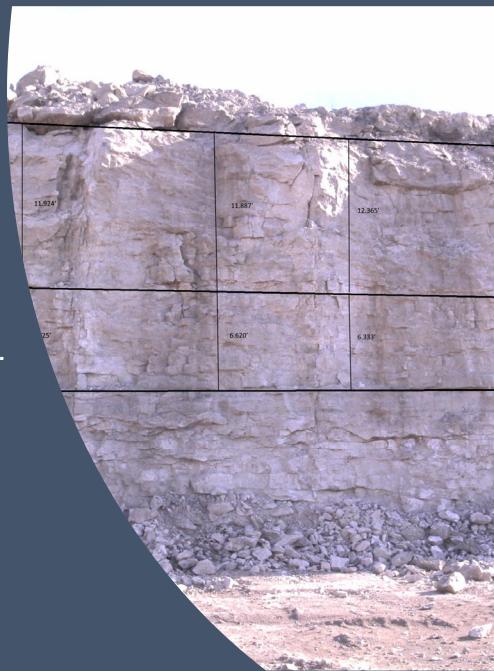

10



11

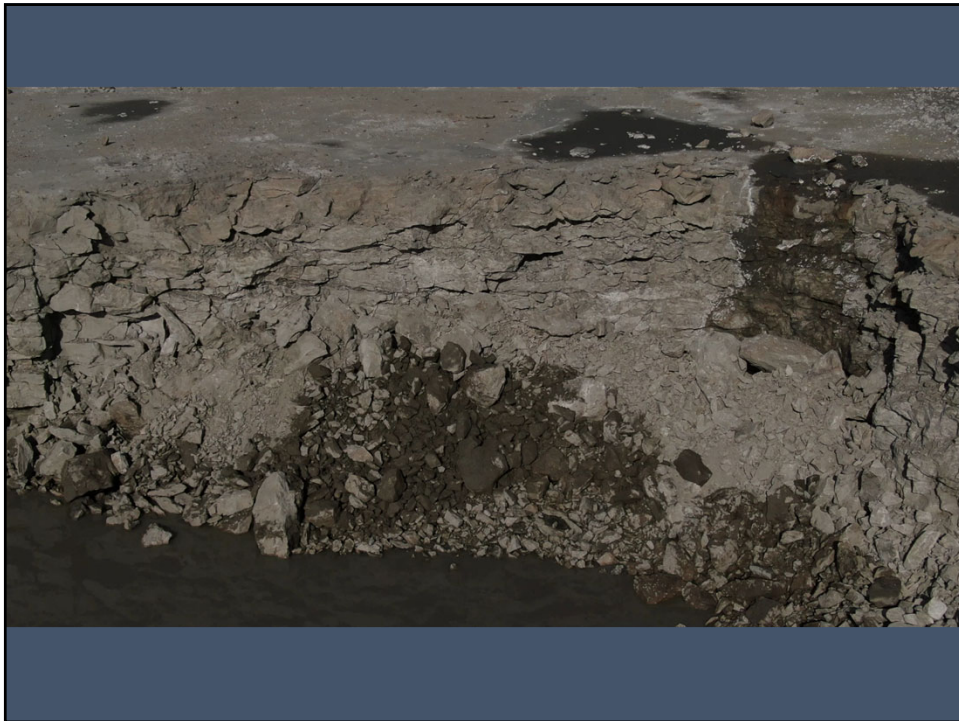

12