

**QC/QA Concrete
Specifications
CTB Workbook**

**Certified Inspector
Training Program**

QC/QA Concrete Spec Cement Treated Base Workbook

Table of Contents

Click on the section name below to be taken to the correct page.

Part 1

1. Quality Assurance
2. CTB Sections 306.1, 306.3-306.5
3. PCCP Sections 501.1, 501.3 and 501.5
4. PCCP Sections 501.4a-f, h, i
5. PCCP Section 501.4g
6. PCCP Sections 501.4j-m

Part 2 Standard Specifications (2015)

7. Section 106 Control of Materials pages 100-53 to 100-56
8. Section 306 Cement Treated Base
9. Special Provision 15-04005 General Concrete sheets 1-2 and 10-11
10. Special Provision 15-04003 On Grade Concrete
11. Section 501 Portland Cement Concrete Pavement (QC/QA)
12. Section 1105 Aggregates for Cement Treated Bases
13. Special Provision 15-11004-R01 Aggregates for On Grade Cement

Part 3 Construction Manual, Part V (2022)

14. Section 5.2.1 Statistics pages 12-26
15. Appendix B Sampling and Testing Frequency Chart
Contractor Quality Control Testing pages 1-4 and 13-14

Reasons for Certified Inspector Training (CIT) Training Program

Overview

The Kansas Department of Transportation (KDOT) has established this training program to educate, test and certify those individuals responsible for performing inspection and testing functions on KDOT construction projects. KDOT's Bureau of Construction and Materials has responsibility for the establishment and administration of the materials portion of the KDOT's Quality Control/Quality Assurance (QC/QA) Program. The Bureau develops standards and specifications for materials, establishes sampling procedures and frequencies, and test procedures used in the laboratory and the field in order to assure compliance with specifications. It performs materials testing to assist each of the six KDOT districts in administering quality assurance functions of the QC/QA Program. Such testing includes tests on materials purchased by contractors or the State for use in maintenance or construction activities. The Bureau also conducts tests on soils, concrete, bituminous mixtures and numerous other specialized materials, the results of which are used by others for a variety of reasons.

Quality control and quality assurance activities involve the routine sampling, testing and analysis of various materials to determine the quality of a given product and to attain a quality product. The goal of the Certified Inspection and Testing Training Program (CIT²) is to provide persons engaged in the inspection and/or testing of KDOT construction projects specific training in, but not limited to, soils, aggregates, and concrete and/or asphalt disciplines.

Each student is required to demonstrate specific abilities as defined by the training modules described in the CIT² manual. The manual can be found online at: <http://www.ksdot.org/descons.asp#CIT>.

Federal Funding

On projects involving federal funds, KDOT must certify to the Federal Highway Administration as to the quality of each type of material used on each project before the State is completely reimbursed by the federal government.

The certification and training requirements contained in this manual are intended to comply with the requirements of 23 CFR Part 637 which states, "After June 29, 2000, all sampling and testing data to be used in the acceptance decision or the IA (Independent Assurance) program shall be executed by qualified sampling and testing personnel."

Reasons for Quality Control/Quality Assurance

Inspectors fulfill a very important job on any project—they safeguard the public interest in a number of ways.

The primary reason for materials inspection, sampling and testing requirements is to verify that all materials incorporated into the work will meet the requirements of the contract documents, including the plans, specifications, and special provisions.

Plans and specifications are prepared to require the use of certain specific materials known or expected to perform satisfactorily with minimum maintenance throughout the life of the facility or infrastructure project. Any material that deviates appreciably from the specifications requirements will not perform as expected and, in all probability, will shorten the useful life of the facility or add unexpected costs in maintenance. Because there are limited dollars available for transportation infrastructure, the useful life and long-term maintenance costs of every project are critical considerations.

Secondly, all contractors bidding or furnishing materials to a project should be treated equally. That is, the contract documents provide a fair and uniform basis for bidding because they define the requirements to be met—ideally with the least possible difference of interpretation. The contractor commits to furnish materials and complete work that will equal or exceed such requirements. For this reason it is essential that quality assurance be correctly understood and applied uniformly by engineers and inspectors from project-to-project so that all contractors and suppliers are treated alike.

Thirdly, the expenditure of public funds must be documented to substantiate whether taxpayers actually received the quantity and quality of materials specified in exchange for tax dollars spent. Whether or not to pay the costs invoiced by contractors is a decision which relies heavily upon inspection reports and test results. In a fundamental way, inspectors play a key role in serving the public—to justify the expenditure of public monies and the acceptance of any contractor's work. Through the work of knowledgeable, competent and skilled inspectors, KDOT can verify and confirm whether or not the contractor has fulfilled its obligations to build the project as intended.

Finally, the specification requirements for materials are constantly evolving, based on new developments, past performance of material in the field, research and technological innovations. Accurate recordkeeping of materials and test results using consistent inspection practices provides a basis to compare results over time—an indispensable advantage for meaningful research. Data properly collected and recorded by inspectors can confirm whether or not changes in material specifications and testing requirements have, in fact, resulted in a better product, state-wide or in a particular location or application.

All inspectors should review the applicable clauses of the Standard Specifications at regular intervals to refresh their understanding of material and testing requirements.

QC/QA PCCP SPECIFICATIONS 2020-2021

Instructor:

Rick Barezinsky, P.E.
Kansas Department of Transportation
Bureau of Construction and Materials
Assistance Bureau Chief

KANSAS STATE
POLYTECHNIC | CIT Program

KANSAS
DEPARTMENT OF TRANSPORTATION

Source for Quality Assurance Information

Specifications

- 106.4 - Contractor QC Requirements for QC/QA Projects (Tab 7)
- 306.2 - Cement Treated Base (CTB) (Tab 8)
- 501.2 - Portland Cement Concrete Pavement (PCCP) (Tab 11)

Construction Manual, Part V

- 5.2 - Quality Control/Quality Assurance (QC/QA)
- Appendix B - Sampling and Testing Frequency Chart (SFTC) for Contractor Quality Control Testing

Quality Assurance

- Who? Contractor, KDOT, Consultants
- What? Inspection, Sampling, and Testing
- Where? Finish Product, Plant Site
- Why? Compliance with Contract Documents
- When? Refer to Specs and Part V, App B
- How? Stay Tuned

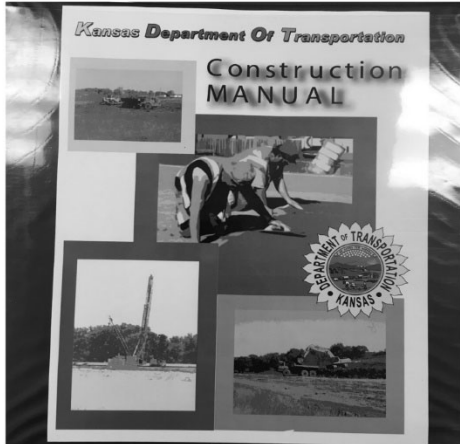

**PART V
OF KDOT'S
CONSTRUCTION
MANUAL**

**MATERIALS
CONTROL**

SECTION 5.1

5.1.1 – Secretary of Transportation
Power, Duty, Authority and Jurisdiction
to inspect and test all materials
used for state highway purposes

This is for the Department's Benefit
not for the benefit of the

- Contractor
- Producer
- Supplier

SECTION 5.1.2

Bureau of Construction & Materials

Establish and Administer:
Materials Portion
Of
KDOT's QC/QA Program

SECTION 5.1.2 BUCAM

- Develop
 - Materials Standards
 - Materials Specifications
- Establish
 - Sampling Procedures
 - Sampling Frequencies
- Establish
 - Field Test Procedures
 - Lab Test Procedures

5.1.1. MATERIALS CONTROL FUNCTIONS OF THE SECRETARY OF TRANSPORTATION

By state statute, the Secretary of Transportation has the power, duty, authority and jurisdiction “to inspect and test all materials...used for state highway purposes or highway projects involving federal funds, and to develop methods and procedures for this purpose.” (K.S.A. 68-404(h)). The Secretary’s inspection and testing of materials and the methods and procedures employed to conduct this inspection and testing are for the Department’s benefit. They are not for the benefit of contractors, producers, or suppliers.

Part V of this Manual and KDOT’s Standard Specifications are two means by which the Secretary fulfills the Secretary’s statutory obligations. Nothing in Part V or KDOT’s Standard Specifications shall be construed to limit KDOT’s discretion to adopt and/or revise standards, specifications, test procedures, removal procedures, or other policies and procedures applicable to the materials used for highway construction/maintenance. Nothing in Part V or KDOT’s Standard Specifications, including without limitation, prequalification or preapproval of materials/sources of material, is a guarantee to contractors, producers, or suppliers that a given material/source of material for highway construction/maintenance will be approved by or remain approved by KDOT, be accepted by KDOT, or be purchased by KDOT or others.

Part V and KDOT’s Standard Specifications include provisions for the Department’s Quality Control/Quality Assurance Program (QC/QA Program), which is required by FHWA to assure the quality of materials and construction in all Federal-aid highway projects and as a condition precedent to use of federal funds. The Department administers its state program in the same manner as its federal program. The Secretary has delegated to the Bureau of Construction and Materials the responsibility for the establishment and administration of the materials’ portion of the Department’s QC/QA Program.

5.1.2. MATERIALS CONTROL FUNCTIONS OF THE BUREAU OF CONSTRUCTION AND MATERIALS

The Bureau of Construction and Materials has responsibility for the establishment and administration of the materials portion of the Department’s Quality Control/Quality Assurance (QC/QA) Program.

The Bureau develops standards and specifications for materials, establishes sampling procedures and frequencies, and establishes testing procedures that are used in the laboratory and the field in order to assure compliance with specifications. The fact that KDOT develops objective specifications and testing criteria and approves or preapproves materials is not intended to limit the Department’s discretion regarding the inspection, sampling, testing and acceptance of materials for highway construction/maintenance.

The Bureau performs materials testing to assist the districts in administering quality assurance functions of the QC/QA Program. Such testing includes tests on materials purchased by contractors or the State for use in maintenance or construction activities. This testing is for KDOT’s benefit not to ensure contractors’ quality control. The Bureau also conducts tests on concrete, bituminous mixtures and numerous other specialized materials, the results of which are used by others. KDOT has no control over or responsibility for the use of KDOT’s materials testing by other entities and no legal duties to such entities.

The responsibility of the Bureau extends to all materials used or proposed for use in State and Federal-aid highway construction and maintenance.

On "full oversight" and "certification acceptance" projects involving Federal funds, the Bureau of Construction and Materials must certify to the Federal Highway Administration as to the quality of each type of material used on each project before the State is completely reimbursed by the Federal Government. On all other projects the bureau reviews project materials records and advises the District Engineer of materials status prior to contract finalization.

To accomplish its various objectives, duties and responsibilities, the Bureau organization consists of the Headquarters Administration office, the Materials and Research Center (MRC), and Regional Laboratories. It also has the assistance of a District Laboratory in each District.

PART V MATERIALS CONTROL

- 5.2.3 Reasons for QC/QA and CIT²
- 5.2.4 Procedures for Quality Assurance
- 5.2.5 QC/QA Tests
- 5.2.6 Comparison of QC and VER Tests
- 5.2.7 Contractor's QC Plan
 - 5.2.7.4 Concrete: Contractor's QC Plan
 - 5.2.7.5 Example: PCCP Lab Quality Manual
 - 5.2.7.8 CTB: Contractor's QC Plan
 - 5.2.7.8.1 Example: CTB Lab Quality Manual

5.2.3 Reasons for QC/QA and CIT²

1. Compliance with Specifications
2. Uniform Relations with Contractors and Producers
3. Documentation of Expenditure of Public Funds
4. Compliance with Federal Regulations

5.2.3 Compliance with Specifications

Primary Reason for Requiring Material

- Inspection
- Sampling
- Testing

Is to Verify All Materials Meet the Requirements of the Contract Documents

- Satisfactory Performance
- Minimal Maintenance
- Deviations ⇒ Shorten Life of the Facility

5.2.3 Uniform Relations: Contractors & Producers

Equitable Basis for Bidding

Contractors provide product that equals or exceeds minimum requirements

State Uses QA to verify receipt of specified product

State uniformly applies QA

- Contractors
- Producers

5.2.3. REASONS FOR QUALITY CONTROL/QUALITY ASSURANCE (QC/QA) AND THE CERTIFIED INSPECTOR TRAINING AND TESTING PROGRAM (CIT²)

1. Compliance with Specifications.

The primary reason for requiring inspection, sampling and testing of materials, through an adequate and effective QC/QA system for materials used in a project, is for KDOT to verify that all materials furnished by the contractor and incorporated into the work and the completed work itself meet the requirements of the contract documents (plans, specifications, special provisions and other supplemental documents).

Specifications and plans have been prepared to require the use of materials that are expected to perform satisfactorily with minimal maintenance throughout the life of the facility. Any material that deviates from specification or plan limits will not perform as expected, and, in all probability, will shorten the life of the facility or add appreciably to the cost of its maintenance. Inspectors are expected to review the applicable clauses and covenants of the Standard Specifications at regular intervals.

2. Uniform Relations with Contractors and Producers.

The contract documents provide an equitable basis for bidding by contractors since they define the requirements that are to be met. The contractors who bid the work and producers supplying material to the contractors commit to KDOT to furnish materials and completed work that will equal or exceed such requirements.

The Engineer must determine, through quality assurance measures that the contractor is providing and the State is receiving what is specified under the contract. The Engineer should accept nothing less for the use of taxpayer funds.

It is essential that quality assurance be applied uniformly by all engineers and inspectors from project to project so that all contractors and suppliers are treated alike. This manual provides guidance to the Engineer and inspector on interpretation of the specifications and the application of quality assurance, so no contractors or producers are given an unfair advantage over other contractors and producers.

5.2.3 Documentation of Expenditure of Public Funds

Pay Contractor for

- Materials furnished
- Work performed

Materials QA system provides the proof

- Test Results
- Inspection Records
- Measurements

Can be used to Accept and Reject Work

5.2.3 Compliance with Federal Regulations

Title 23, Chapter 1, Part 637 of CFR

Requires State DOT's

- Have a QA Program
- Testing by Qualified Laboratories
- Independent Assurance Program
- Random Sampling of Materials
- Use Qualified Personnel (CIT²)
 - Sampling
 - Testing

3. Documentation of Expenditure of Public Funds.

When payment is to be made to the contractor for materials furnished and work performed, the duly designated state official must authorize disbursement of public funds for this purpose. The disbursing officer must depend upon others for evidence to support the expenditure. Through the materials quality assurance system, the Field Engineer will acquire substantiating data in the form of test results, inspection records and measurements to justify acceptance of the contractor's work. Thus the Engineer can assure and furnish documentation to the officials responsible for authorizing payment that the contractor has fulfilled its obligation and is entitled to full or adjusted payment as provided for in the contract documents.

In case of failure to meet the minimum requirements, quality assurance data will constitute the basis for rejection of work as unacceptable.

Complete records, including test and inspection reports covering acceptance or rejection, should be maintained in the Engineer's project files while the necessary copies should be furnished to the appropriate headquarters personnel as needed for verification and as supporting evidence for payment documents.

4. Compliance with Federal Regulations

Title 23, Chapter 1, Part 637 of the Code of Federal Regulations includes many requirements which must be adhered to for Federal-aid highway construction. Some of these requirements include:

- State Transportation Departments have a Quality Assurance program in place.
- Testing of highway materials is performed by Qualified Laboratories.
- State Transportation Departments have an Independent Assurance program in place.
- Sampling of materials used in highway construction is accomplished in a Random manner.
- Qualified personnel are used for sampling and testing of materials used in highway construction.

...

5. Reasons for the Certified Inspection and Testing Training Program (CIT²).

As noted above, the use of qualified personnel is required for sampling and testing of materials used in highway construction. This requirement is expressed in 637.209(b) "Sampling and testing personnel. After June 29, 2000, all sampling and testing data to be used in the acceptance decision or the IA program shall be executed by qualified sampling and testing personnel." The State defines qualified personnel as those certified through the Certified Inspection and Testing Training Program (CIT²).

The following is an excerpt from the CIT² manual giving an overview of the program:

"The Kansas Department of Transportation (KDOT) has established this training program to educate, test and certify those individuals responsible for performing inspection and testing functions on KDOT construction projects. KDOT's Bureau of Construction and Materials has responsibility for the establishment and administration of the materials portion of the KDOT's Quality Control/Quality Assurance (QC/QA) Program. The Bureau develops standards and specifications for materials, establishes sampling procedures and frequencies, and test procedures used in the laboratory and the field in order to assure compliance with specifications. It performs materials testing to assist each of the six KDOT districts in administering quality assurance functions of the QC/QA Program. Such testing includes tests on materials purchased by contractors or the State for use in maintenance or construction activities. The Bureau also conducts tests on soils, concrete, bituminous mixtures and numerous other specialized materials, the results of which are used by others for a variety of reasons."

"Quality control and quality assurance activities involve the routine sampling, testing and analysis of various materials to determine the quality of a given product and to attain a quality product. The goal of the Certified Inspection and Testing Training Program (CIT²) is to provide persons engaged in the inspection and/or testing of KDOT construction projects specific training in, but not limited to, soils, aggregates, and concrete and/or asphalt disciplines." . . .

5.2.4 Procedures for Quality Assurance

1. General

1.1 Method Specs – KDOT tests for QA

1.2 QC/QA Specs

- Contractor QC tests for acceptance
- KDOT tests to verify QC tests

2. Authorized Personnel

3. Inspection and Sampling Procedures

5.2.4. PROCEDURES FOR QUALITY ASSURANCE

1. General

KDOT has two procedures for assuring quality on project produced materials. The two Sampling and Testing Frequency Charts in Appendix A and B help clarify some of the differences between the two procedures.

1.1. The older of the two is “Method Specs”. Under this procedure, KDOT’s test results are used as the basis of acceptance for project produced materials, and the contractor is not required to conduct quality control testing, although the contractor may choose to do so.

1.2. A more current procedure is “QC/QA” specifications. Under this method of quality assurance, the contractor conducts quality control testing, and these test results can be used as a basis of acceptance, provided KDOT’s quality assurance verifies the results.

2. Authorized Personnel.

2.1. Under a “method spec”, all inspection, sampling and testing for acceptance must be performed by an authorized representative of the Kansas Department of Transportation. The representative may be an employee of the Kansas Department of Transportation, an employee of another highway agency or an employee of a commercial testing laboratory or inspection agency. The contractor's/producer's process control test results may be used for partial acceptance when allowed by the contract documents. (See basis of acceptance.)

Arrangements for inspection and sampling of materials by agencies other than the Department are made by the Chief, Bureau of Construction and Materials.

Samples submitted to the laboratory for tests by unauthorized individuals or agencies will not be tested except by authorization of the Chief, Bureau of Construction and Materials.

2.2. Under “QC/QA” specifications, all technicians must demonstrate qualifications for each Test Group in which they wish to conduct materials sampling and testing. These qualifications include some type of certificate for the completion of a training program or a combination of demonstration of the test procedures and completion of written exams covering the group of test methods. For a list of Test Groups, see **Appendix C**. Acceptable certifications include KDOT training and testing, training conducted at KSU-Salina or Manhattan, American Concrete Institute certification, or a certificate of completion from a program similar to those described and issued or approved by another state’s DOT. KDOT has final judgment on a technician’s qualifications.

Certification in one group may be required before attendance in the certification course of another group. For example, Aggregate Field is required before a technician may attend the Superpave Field training.

All contractors conducting QC/QA sampling and testing for KDOT projects are responsible for the annual calibration and verification of their equipment by an AASHTO Accredited Laboratory using NIST traceable equipment, or by some other NIST traceable source (see **Appendix C** for calibration and verification frequencies). Calibrations and verifications required more often than every 12 months may be conducted by the contractor if the equipment is checked annually by an AASHTO Accredited Laboratory. Equipment will be made available to the District Materials Engineer for spot checks of the calibrations when necessary.

5.2.5
Quality Control/Quality Assurance
(QC/QA) Tests

2. Definitions

- 2.1. **Acceptance Program** – How we determine if material/work meets contract requirements.
- 2.2. **Assurance Sampling and Testing** – Independent check of sampling, testing, and equipment using split or replicate samples.
- 2.3. **Dispute Resolution** – Resolve conflicts between State’s verification results and the Contractor’s quality control results
- 2.4. **Independent Assurance (IA)** – Performed by District Lab. Unbiased and independent verification of the QA system.

5.2.5
Quality Control/Quality Assurance
(QC/QA) Tests

2. Definitions

- 2.5. **Quality Assurance (QA)** – Includes all activities associated with acceptance, IA, verification, and prequalification; inspection; reporting; and follow up.
- 2.6. **Quality Control (QC)** – Contractor activities i.e. sampling, testing, equipment calibrations, and documentation.
- 2.7. **Qualified Laboratories** – Approved through KDOT approved programs

5.2.5. QUALITY CONTROL/QUALITY ASSURANCE (QC/QA) TESTS

1. General

This section establishes terminology and procedures for the various tests that are included in the QC/QA system.

2. Definitions

2.1. Acceptance Program - All factors that comprise the State's determination of the degree of compliance with contract requirements and value of a product. These factors include the State's sampling, testing and inspection, and validated results of contractor sampling and testing.

2.2. Assurance Sampling and Testing - Split or replicate samples used as an independent check of the sampling and testing procedures and equipment. These samples are to assure testing is being performed properly by both the contractor's and the State's personnel. The results of assurance tests are not to be used as a basis of material acceptance.

2.3. Dispute Resolution - The procedure used to resolve conflicts resulting from discrepancies between the State's verification results and the Contractor's quality control results of sufficient magnitude to impact payment. Any laboratory used for dispute resolution must be accredited by the AASHTO Accreditation program for the tests to be performed.

2.4. Independent Assurance (IA) - IA is an unbiased and independent verification of the Quality Assurance system used and of the reliability of the test results obtained in the regular sampling and testing activities. KDOT's IA will consist of observations by independent personnel to assure that specified procedures are followed (witnessing), and split or replicate sampling and testing.

2.5. Quality Assurance (QA) - All those planned and systematic actions necessary to provide adequate confidence that a product or service will satisfy given requirements for quality. QA activities include: acceptance, independent assurance, verification, and prequalification sampling and testing; inspection; reporting of results; and any follow up that may be necessary due to test failure. Without these actions, it would be impossible for the Engineer to accurately verify compliance or in many cases the level of compliance with the requirements of the contract documents.

2.6. Quality Control (QC) - The sum total of operational techniques and activities performed or conducted by the contractor and/or producer to make sure that a product meets contract specification requirements. QC activities generally are outlined in a contractor's process control plan which lists such items as types of tests to be performed, sampling locations, sampling frequencies, equipment calibration procedures and frequencies, and documentation procedures.

2.7. Qualified Laboratories - Laboratories used for sampling and testing of materials are those approved through appropriate programs as determined by KDOT.

5.2.5
Quality Control/Quality Assurance
(QC/QA) Tests

2. Definitions

- 2.8. **Qualified Technician** - Personnel who are certified through KDOT approved programs.
- 2.9. **Replicate Tests** - Tests performed on project material by IA personnel using equipment other than what's used for QC or Verification testing.
- 2.10. **Split Samples** - Testing different portions of the same sample by different labs to compare testers and equipment.

5.2.5
Quality Control/Quality Assurance
(QC/QA) Tests

2. Definitions

- 2.11. **Verification Sampling and Testing** - Independent samples obtained and tested by KDOT to validate QC results.
- 4. Comparison Procedures**
- 4.2. Use F&t tests to statistically compare contractor QC tests with KDOT's verification test.
- Passing t test - Accept using Contractor data
 - Failing t test - Accept using KDOT's data
- 6. Sampling and Testing Frequency**
- Appendix A - Method Specs
 - Appendix B - QC/QA Specs

2.8. Qualified Technician - Personnel who are certified through appropriate programs as determined by KDOT.

2.9. Replicate Tests - Tests performed by independent assurance personnel using equipment other than that used by project personnel, but performed on a portion of the sample used by project personnel.

2.10. Split Samples - Sampling and splitting of the material conducted under the observation of independent assurance personnel. Tests on separate portions are performed by KDOT designated independent assurance personnel using equipment other than that used by project personnel.

2.11. Verification Sampling and Testing - Sampling and testing performed to validate the quality of the product or to check the adequacy of mix designs. If quality control sampling and testing is used in the acceptance program, verification sampling and testing will also be used to validate the quality control sampling and testing. Verification samples are independent samples obtained by KDOT.

...

4. Comparison Procedures

4.2. Under a “method spec” the numerical results obtained on Verification Samples are compared promptly with the specifications, or certified results, as applicable. Appropriate action is taken by the person responsible for making comparisons in each case. In the case of verification sample test results obtained at the MRC, the Engineer of Tests informs the district of any test results which do not comply with specifications and retains the reports pending receipt of information from the district regarding its investigation of circumstances for non-compliance and corrective action taken, if needed, resulting from its investigation.

Under QC/QA specifications, Verification test results are statistically compared to the contractor’s test results by the use of the F and T tests outlined in **section 5.2.6.** or some other statistically valid practice. Use F & T tests only when enough verification results are available. KDOT prefers results from at least 3 to 5 verification tests for statistical comparisons. If the data passes the T test, use the contractor’s numbers to calculate pay quantities. If the data fails the T test, use KDOT’s numbers to calculate pay quantities.

...

6. Sampling and Testing Frequency

6.1. The two **Sampling and Testing Frequency Charts (Appendix A and Appendix B)** reflect the minimum rate for sampling and testing. It is understood that if a problem occurs, more samples or tests may be necessary.

6.1.1. It is also intended that Verification and Assurance Samples may be used for items other than those required by the Sample and Testing Frequency Chart. However, Assurance Samples will never be used for Acceptance.

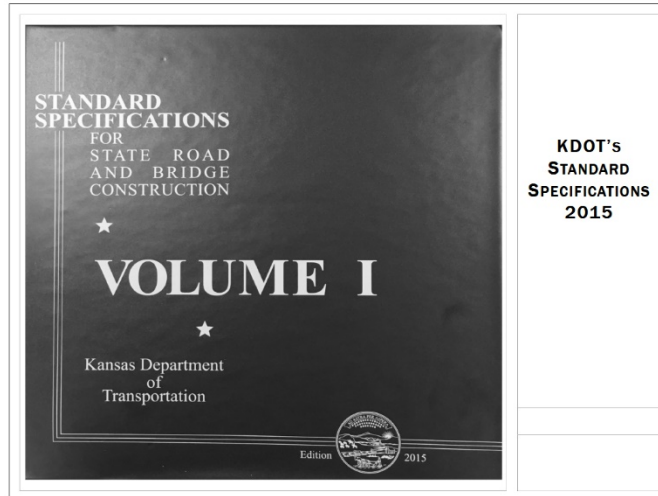

**Contractor Quality Control Requirements
Common to both Section 306 and 501**

We will spend most of our time in 501.2

a) General

Provide

- Qualified Personnel
- Sufficient Equipment That Complies with KDOT Construction Manual, Part V To conduct QC/QA Testing Which Complies with Appendix B – Sampling and Testing Frequency Chart

**Contractor Quality Control Requirements
Common to both Section 306 and 501**

a) General

Allow Engineer Access to Lab to Observe

- Testing Procedures
- Calculations
- Test Documentation
- Plotting of Test Results

Testing Equipment (Detail in Part V)

- Calibrate/Correlate to Prescribed Procedures
- Test per Part V

**Contractor Quality Control Requirements
Common to both Section 306 and 501**

a) General

Maintain a Quality Manual in Field Lab

- Calibrations for Test Equipment
- Calibration Intervals in Part V:
 - PCCP (SS 501):
 - Section 5.2.7.4-Concrete: Contractor's Quality Control Plan
 - CTB (SS 306):
 - Section 5.2.7.8-Cement Treated Base: Contractor's Quality Control Plan (CTB)

**Contractor Quality Control Requirements
Common to both Section 306 and 501**

b) Quality Control Plan (QCP)

- Submit at Pre-Con
- *Part V says to submit it 30 days before work begins*
- Keep Printed Copy in Contractor's Lab
- Make available to Engineer upon request
- Inspect and Approve Lab and Equipment
 - Table 1 in Part V Section 5.2.7.4
 - Table 1 in Part V Section 5.2.7.8 (CTB)

**SECTION 501
PORTLAND CEMENT CONCRETE PAVEMENT (QC/QA)**

Note: PCCP is considered QC/QA when the bid item Quality Control Testing is included in the contract. Note the exceptions in subsection 501.5.

501.1 DESCRIPTION

Construct Portland Cement Concrete Pavement (PCCP) on a prepared subgrade or base course. Develop and perform quality control testing.

Urban PCCP Environment: Projects or sections of the project classified as Urban Type are typically:

- within city limits;
- require pieced construction due to:
 - business and residential entrances;
 - frequency of side streets; or
 - project phasing.

Before paving, meet with the Engineer to determine if the project or sections of the project are classified as Urban Type.

BID ITEMS

Concrete Pavement (* Uniform) (AE) (**)
Concrete Pavement (* Variable) (AE) (**)
Early Strength Concrete Pavement (*Uniform) (AE) (**)
Early Strength Concrete Pavement (*Variable) (AE) (**)
Quality Control Testing (PCCP)⁺
Concrete Core (Set Price)

UNITS

Square Yard
Square Yard
Square Yard
Square Yard
Square Yard
Each

* Thickness

** No entry denotes PCCP with mesh and dowel assemblies. "Plain" denotes PCCP without mesh and dowel assemblies. "NRDJ" denotes non-reinforced dowel jointed PCCP. "Br App" denotes bridge approach pavement.

⁺ Br App pavement quantities are not included in this item.

501.2 CONTRACTOR QUALITY CONTROL REQUIREMENTS

a. General. Provide qualified personnel and sufficient equipment complying with the requirements listed in Part V to conduct quality control testing that complies with Appendix B, Sampling and Testing Frequency Chart for Concrete Construction Items for Quality Control/Quality Assurance Projects.

Allow the Engineer access to the Contractor's laboratory to observe testing procedures, calculations, test documentation and plotting of test results.

Calibrate and correlate the testing equipment with prescribed procedures, and conduct tests in compliance with specified testing procedures as listed in Part V.

Maintain a Quality Manual in the field laboratory showing the calibrations performed on all test equipment and when the next calibration is due for that equipment. As a minimum, follow the calibration/verification interval established in Table 1: Concrete Materials Test Equipment in Section 5.2.7.4-Concrete: Contractor's Quality Control Plan, Part V. See also Section 5.2.7.5-Example of a Laboratory Quality Manual for Concrete, Part V.

b. Quality Control Plan (QCP). At the pre-construction conference, submit to the Engineer for approval by the DME, a QCP as outlined in Section 5.2.7.4-Concrete: Contractor's Quality Control Plan, Part V. Follow 5.2.7.4: Concrete: Contractor's Quality Control Plan in Part V as a general guideline. Keep a printed copy of the approved QCP in the Contractor's laboratory and make available to the Engineer when requested.

The Contractor's laboratory and equipment will be inspected and approved as outlined in Section 5.2.7-Contractor's Quality Control Plan, Part V.

Contractor Quality Control Requirements
Common to both Section 306 and 501

- b) Quality Control Plan (QCP)
- QC Administration and Inspection
 - Include list of names and phone numbers
 - Individuals and Alternates responsible for QC
 - Contractor's Organizational Chart
 - Post it in Contractor's Test Facility
 - Show specified lines of authority
- Mix Design QC Operations during
 production

Contractor Quality Control Requirements
Common to both Section 306 and 501

- b) Quality Control Plan (QCP)
- Certified Testers (CIT² Program)
 - Quality Control Organization
 - Private Testing Firm
 - Certified for the test being performed
 - Provide Engineer with list of certified technicians
 - Check expiration dates
 - Keep list current

Contractor Quality Control Requirements
Common to both Section 306 and 501

- b) Quality Control Plan (QCP)
- **Required Certifications for PCCP/CTB**
 - Aggregate Field Tester (AGF)
 - ACI Concrete Field Testing Technician (CF)
 - Nuclear Density Gauge Tester (NUC)
 - QC/QA PCCP/CTB (QCS) (at least 1 person)
 - **Required Certifications for PCCP**
 - Aggregate Lab Technician (AGL)
 - Profilograph (PO)
 - Hardened Concrete Properties (HCP)
 - **Required Certifications for CTB**
 - Soils Field Tester (SOF)

Contractor Quality Control Requirements
Common to both Section 306 and 501

- b) Quality Control Plan (QCP)
- Identify
 - Company Official Acting as Liaison with KDOT
 - Certified Technician who will direct Inspection and Testing
 - Post Organizational Chart in the Test Facility

Contractor Quality Control Requirements
Section 306.2

- b) Quality Control Plan (QCP)
- Submit Mix Design
 - Methods/Procedures to Control Quality
 - Producing the Aggregate
 - Managing Aggregate Stockpiles
 - Proportioning
 - Mixing and Transporting Mixture
 - Placing and Consolidating Mixture
 - Finishing and Curing Mixture
 - Quality of Components (5.2.7.8)
 - Initial Mix Properties (5.2.7.8)
 - Compressive Strength (5.2.7.8)

Include a listing of the names and phone numbers of individuals and alternates responsible for quality control administration and inspection. On the Contractor's organizational chart, show the specified lines of authority relating both to mix design and quality control operations during production. Post the organizational chart in the Contractor's test facility.

Provide a quality control organization or private testing firm having personnel certified according to the Policy and Procedures Manual for The Certified Inspection and Testing (CIT) Training Program. The testing for this type of construction will require personnel certified in Aggregate Field Tester (AGF), Aggregate Lab Technician (AGL), Profilograph (PO), ACI Concrete Field Testing Technician (CF), Nuclear Moisture Density Gauge Tester (NUC) and Hardened Concrete Properties (HCP) classifications. Provide a minimum of 1 employee on the project certified in the QC/QA Concrete/Cement Treated Base Specs (QCS) classification.

Only persons certified in the appropriate classifications covering the specific tests required shall perform such testing. At the beginning of the project, provide the Engineer with the list of certified technicians and alternates, phone numbers and tests/inspection they will be performing. As personnel changes and certifications may expire, continue to provide the Engineer with an accurate list.

Provide an organizational chart showing the specified lines of authority relating to both mix design and quality control operations during production. Identify the company official acting as liaison with KDOT, and the Certified Technician who will direct inspection and testing. Post the chart in the test facility.

c. Required Duties of Certified Technicians. Be available on the project site whenever concrete for pavement is being produced and being placed on the project site. Perform and utilize quality control tests and other quality control practices to assure that delivered materials and proportioning meet the requirements of the mix designs.

Periodically inspect all equipment utilized in transporting, proportioning, mixing, placing, consolidating, finishing and curing to assure it is operating properly and that placement, consolidation, finishing and curing comply with the mix design and other contract requirements.

d. Contractor's Testing Facilities. Describe the testing facility and its accreditation in the QCP.

Locate the testing facility either at the plant site or at the project. Obtain approval of the testing facilities and location from the DME before the commencement of mixture production.

Provide suitable space for the required testing equipment. Also, equip the testing facility with these items for the exclusive use of the testing facility's quality control personnel and the Engineer:

- A telephone with a private line;
- A copying machine; and
- Broadband internet connection (for 1 computer). If the Engineer determines that broadband internet service is not available, provide a fax machine, at no additional cost.

e. Documentation. Include in the QCP procedures, charts and forms to be used to provide the required documentation.

Record and document all test results and calculations. Record all original documentation in a bound field book or other KDOT approved bound record and turn over to KDOT at the end of the project.

At all times, have complete records of all inspections and tests readily available on site for the Engineer. All records documenting the Contractor's quality control inspections and tests become the property of KDOT upon completion of the work.

Indicate the nature and number of observations made, the number and type of deficiencies found, the quantities approved and rejected, and the corrective action taken in the records. Examples of quality control forms and charts are available in Part V, or Contractors may design their own. Documentation procedures are subject to approval by the Engineer before the start of the work and to compliance checks during the progress of the work.

Maintain control charts on an ongoing basis. Plot data according to **SECTION 106**.

Record specific test results on a Daily Quality Control Summary sheet designed to facilitate the computation of moving test averages. Base moving averages on 4 consecutive test results. Include a description of quality control actions taken (such as adjustment of aggregate or additive proportions in the mix, moisture adjustments) in the Daily Quality Control Summary Sheet.

Contractor Quality Control Requirements
Common to both Section 306 and 501

c) Required Duties of Certified Technicians

- Be available on the project site whenever PCCP/CTB is being produced and placed
- Perform QC tests and other QC Practices
 - Assure mix design requirements are met
 - Delivered Materials
 - Proportioning
- Periodically inspect all equipment
 - Assure it is operating properly
 - Product complies with mix design and other contract requirements

Contractor Quality Control Requirements
Common to both Section 306 and 501

d) Contractor's Testing Facilities

- Describe accreditation in the QCP
- Contractor's testing Lab at plant site or project
- DME approves testing facilities and location before mix production
- Suitable Space for Test Equipment
- For QC Personnel and Engineer Use
 - Telephone with private line
 - Copying machine
 - Broadband Internet connection (fax machine)

Contractor Quality Control Requirements
Common to both Section 306 and 501

e) Documentation

- Original in a Bound Field Book
- Charts – Keep Current
- Forms – Computer-acceptable medium
- Test Results (Use Electronic Data Sheets)
- Calculations (Use Electronic Data Sheets)
- Records of Inspections
 - Observations (nature and number)
 - Deficiencies (number and type)
 - Quantities (approved and rejected)
 - Corrective actions taken

Contractor Quality Control Requirements
Common to both Section 306 and 501

e) Documentation

- Control Charts (Section 106)
- Daily Quality Control Summary Sheet
 - Specific Test Results
 - 4-Point Moving Averages
 - QC Actions Taken
 - Aggregate Adjustments
 - Additive Proportion Adjustments
 - Moisture Adjustments
 - Document
 - Batch and Weigh Tickets
 - Gradation data

Include a listing of the names and phone numbers of individuals and alternates responsible for quality control administration and inspection. On the Contractor's organizational chart, show the specified lines of authority relating both to mix design and quality control operations during production. Post the organizational chart in the Contractor's test facility.

Provide a quality control organization or private testing firm having personnel certified according to the Policy and Procedures Manual for The Certified Inspection and Testing (CIT) Training Program. The testing for this type of construction will require personnel certified in Aggregate Field Tester (AGF), Aggregate Lab Technician (AGL), Profilograph (PO), ACI Concrete Field Testing Technician (CF), Nuclear Moisture Density Gauge Tester (NUC) and Hardened Concrete Properties (HCP) classifications. Provide a minimum of 1 employee on the project certified in the QC/QA Concrete/Cement Treated Base Specs (QCS) classification.

Only persons certified in the appropriate classifications covering the specific tests required shall perform such testing. At the beginning of the project, provide the Engineer with the list of certified technicians and alternates, phone numbers and tests/inspection they will be performing. As personnel changes and certifications may expire, continue to provide the Engineer with an accurate list.

Provide an organizational chart showing the specified lines of authority relating to both mix design and quality control operations during production. Identify the company official acting as liaison with KDOT, and the Certified Technician who will direct inspection and testing. Post the chart in the test facility.

c. Required Duties of Certified Technicians. Be available on the project site whenever concrete for pavement is being produced and being placed on the project site. Perform and utilize quality control tests and other quality control practices to assure that delivered materials and proportioning meet the requirements of the mix designs.

Periodically inspect all equipment utilized in transporting, proportioning, mixing, placing, consolidating, finishing and curing to assure it is operating properly and that placement, consolidation, finishing and curing comply with the mix design and other contract requirements.

d. Contractor's Testing Facilities. Describe the testing facility and its accreditation in the QCP.

Locate the testing facility either at the plant site or at the project. Obtain approval of the testing facilities and location from the DME before the commencement of mixture production.

Provide suitable space for the required testing equipment. Also, equip the testing facility with these items for the exclusive use of the testing facility's quality control personnel and the Engineer:

- A telephone with a private line;
- A copying machine; and
- Broadband internet connection (for 1 computer). If the Engineer determines that broadband internet service is not available, provide a fax machine, at no additional cost.

e. Documentation. Include in the QCP procedures, charts and forms to be used to provide the required documentation.

Record and document all test results and calculations. Record all original documentation in a bound field book or other KDOT approved bound record and turn over to KDOT at the end of the project.

At all times, have complete records of all inspections and tests readily available on site for the Engineer. All records documenting the Contractor's quality control inspections and tests become the property of KDOT upon completion of the work.

Indicate the nature and number of observations made, the number and type of deficiencies found, the quantities approved and rejected, and the corrective action taken in the records. Examples of quality control forms and charts are available in Part V, or Contractors may design their own. Documentation procedures are subject to approval by the Engineer before the start of the work and to compliance checks during the progress of the work.

Maintain control charts on an ongoing basis. Plot data according to **SECTION 106**.

Record specific test results on a Daily Quality Control Summary sheet designed to facilitate the computation of moving test averages. Base moving averages on 4 consecutive test results. Include a description of quality control actions taken (such as adjustment of aggregate or additive proportions in the mix, moisture adjustments) in the Daily Quality Control Summary Sheet.

Contractor Quality Control Requirements
Common to both Section 306 and 501

e) Documentation

- Complete testing and charting within 1 working day after sampling
- Charting
 - Individual Test Results
 - 4 Point Moving Average Values

Contractor Quality Control Requirements
Section 501.2

e) Documentation

- Properties to Chart
 - Percent Air
 - Slump
 - Unit Weight
 - In-place plastic concrete density
 - Percentage of determined Unit Weight
 - Combined aggregate gradation (minimum)
 - 3/8" Sieve
 - No. 8 Sieve
 - Actual and Target Workability of the combined aggregates. (Single Point only)

Contractor Quality Control Requirements
Section 501.2

e) Documentation

- Provide to KDOT Project Representative
 - Weekly Basis
 - Test results
 - Control Charts
 - Recap of Vibrator Checks

Contractor Quality Control Requirements
Section 501.2

e) Documentation

- Quality Control Summary Sheet (Daily)
 - Percent Air
 - Slump
 - Unit Weight
 - In-place plastic concrete density
 - Percentage of determined Unit Weight
 - Combined aggregate gradation
 - Actual and Target Workability of the combined aggregates
- Failing Test Results
- Copies of Vibrator Checks

Contractor Quality Control Requirements
Section 306.2

306.2e) Documentation

- Quality Control Summary Sheet (Daily)
 - Gradation of Combined Aggregates
 - In-place CTB moisture
 - CTB Dry Density
 - Compressive Strength (Single Point Only)
- Submit to Engineer Daily
 - Failing Test results
 - Summary Sheet

501.2e – Portland Cement Concrete Pavement

Provide forms on a computer-acceptable medium, where required. Document tickets and gradation data according to KDOT requirements.

Complete testing and charting within 1 working day after sampling.

Keep all quality control charts current. Show both individual test results and moving average values. As a minimum on approved control charts, plot the single test values and the 4 test moving average values for these properties:

- Percent air in concrete mixture;
- Slump of concrete mixture;
- Concrete unit weight;
- In-place concrete density on plastic concrete as a percentage of determined unit weight; and
- Combined aggregate gradation (as a minimum, plot the 3/8" and No. 8 sieves).

Also plot the single test values for actual workability and target workability of the combined aggregates.

Provide the following test data to the KDOT Project Representative:

- Copies of all test results and control charts on a weekly basis, representing the prior week's production;
- Copies of the quality control summary sheet on a daily basis. Include, as a minimum, combined aggregate gradations, actual workability and target workability of combined aggregates, percent air content, slump, concrete unit weight and density of fresh concrete in-place; and
- Copies of all failing test results. Include all applicable sieves, actual workability, percent air content, slump and density of fresh concrete in-place.
- Copies of vibrator checks daily to the Inspector. Email a weekly recap to the Construction Engineer.

Email or fax the data to the Field Engineer and DME, weekly.

306.2 – Cement Treated Base

e. Documentation. Include in the QCP procedures, charts and forms to be used to provide the required documentation.

...

Maintain control charts on an ongoing basis. Plot data according to **SECTION 106**.

Record all test results and calculations on electronic data sheets. Record specific test results on a Daily Quality Summary Sheet to facilitate the computation of moving test averages. Base the moving averages on 4 consecutive test results. Include a description of quality control actions taken (adjustment of aggregate or additive proportions in the mix, moisture adjustments, etc.) in the Daily Quality Summary Sheet.

Provide forms on a computer-acceptable medium, where required. Document batch tickets and gradation data according to KDOT requirements.

Complete testing and charting within 1 working day after sampling.

Keep all quality control charts current. Email or fax the data to the Field Engineer and DME, weekly. Show both individual test results and moving average values. As a minimum, plot the single test values and the 4-test moving average values for gradation of combined aggregates, in-place CTB moisture and dry density, and compressive strength (requires a separate graph for PWL, but no moving average plot).

Complete the charting within 1 working day after the sampling or testing, respective to each type of test.

Make all test results and control charts available to the Engineer at the project site. The Engineer will periodically make compliance checks on the documentation during the progress of the work.

Submit (email or fax) copies of all failing test results (based on a moving average of 4 tests, if appropriate) and a summary sheet to the Field Engineer on a daily basis.

File all reports, records, charts and diaries developed during the progress of construction activities. Upon completion of the contract, all documentation becomes the property of KDOT.

Contractor Quality Control Requirements
Common to both Section 306 and 501

f) Testing Requirements

- Identify in the QC Plan
 - Test Methods – Standard KT’s
 - Test Procedures
 - Test Equipment – Properly Calibrated
 - Detail alternative
 - Sampling Methods
 - Procedures
 - Inspection Equipment
- Obtain samples randomly
 - Select per QC plan
 - Rates in STFC in Appendix B, Part V
 - Retain last 10 gradation samples

Contractor Quality Control Requirements
Common to both Section 306.2h and 501.2g

g/h) Corrective Actions

- QC Plan
 - ID procedures for notifying Engineer
 - Corrective Actions need implemented
 - Moving Average Test Result approaches the Specification Limits
- Halting Operations
 - 2 Consecutive Moving Average Points fall outside the Specification Limits
 - 2 Consecutive compressive strength tests exceed the specification limits (CTB)
 - Contractor’s Responsibility

Contractor Quality Control Requirements
Common to both Section 306.2h and 501.2g

g/h) **Corrective Actions**

Halting Operations PCCP and CTB

- Aggregate Gradation
- Mix Design Band

Halting Operations PCCP

- Percent Air Content
- Concrete Unit Weight
- Density of Fresh in-place Concrete

Halting Operations CTB

- In-Place Density of CTB

Contractor Quality Control Requirements
Common to both Section 306.2h and 501.2g

g/h) **Corrective Actions**

Failure to Cease Operations (Engineer)

- Subsequent Material subjected
 - to Rejection
 - Acceptance at a Reduced Price

Additional Testing

- Results are beyond normal variance
- Used to define unacceptable work
- May result in
 - Price Reductions
 - Corrective Actions

Contractor Quality Control Requirements
Common to both Section 306.2h and 501.2g

g/h) **Corrective Actions**

Dispute (not Compressive Strength)

- Referee Testing
 - KDOT District Materials Lab
 - KDOT MRC
 - Independent Lab
 - Both Parties Agree
 - AASHTO Accredited
- If KDOT’s results are upheld
 - Contractor pays cost of testing (vice versa)
- Compressive Strength or Thickness
 - See Subsection 501.5g (4)

Contractor Quality Control Requirements
Common to both Section 306.2i and 501.2h

h/i) **Non-Conforming Materials**

In the Quality Control Plan

- Address how controlled and identified
- ID, Isolate, and Dispose
- Reclaim or Rework
 - Procedures acceptable to Engineer
 - Engineer determines if allowed (CTB)
- Prevent
 - Use
 - Shipment
 - Intermingling
 - Provide Holding Areas

501.2e – Portland Cement Concrete Pavement

f. Testing Requirements. In the QCP, identify test methods, procedures and equipment proposed for use. Use standard KDOT test methods and properly calibrated measuring and testing equipment as outlined in Part V. Detail any alternative sampling method, procedure or inspection equipment proposed to be used. Such alternatives are subject to review and approval by the DME.

Take all samples for tests and perform in-place tests at random locations, selected according to the Contractor's QC Plan and at the rates specified in the Sampling and Testing Frequency Chart for Portland Cement Concrete Pavement for Quality Control/Quality Assurance Projects in Appendix B, Part V. Retain the latest 10 gradation samples for use by the Engineer.

g. Corrective Action. In the QCP, identify procedures for notifying the Engineer when corrective measures must be implemented, and for halting production.

Notify the Engineer when the moving average test result trend line for any property approaches the specification limits. Cease operations if 2 consecutive moving average points fall outside the specification limits. Ceasing operations is the Contractor's responsibility. Quality control tests for this determination include aggregate gradation, compliance with the mix design band, percent air content, concrete unit weight and density of fresh concrete in-place.

Failure to cease operations for the conditions cited above will subject all subsequent material to rejection, or acceptance at a reduced price, as determined by the Engineer.

The Engineer may examine materials represented by individual test results, which lie beyond the Contractor's normal quality control testing variation. The investigation may be based on either Contractor or KDOT test results. The information from additional testing (including testing of in-place pavement) may be used to define unacceptable work according to **SECTION 105**. The Engineer will apply appropriate price reductions or initiate corrective action.

If a dispute exists between the Engineer and Contractor about the validity of any test results other than compressive strengths or thickness determination, the KDOT District Materials Laboratory or MRC will perform referee testing. If one of the disputed KDOT test results was generated at the MRC, then an independent laboratory agreeable to both parties will be selected. The AASHTO Accreditation Program shall have approved the selected laboratory for the appropriate test procedure. If referee testing indicates that KDOT test results are correct, the Contractor is responsible for the cost of additional testing, including referee testing performed at the MRC. If the referee testing indicates that the Contractor test results are correct, KDOT is responsible for the cost of additional testing.

Follow the procedures outlined in **subsection 501.5g.(4)** if a dispute arises for any test determining compressive strengths or thickness.

h. Non-Conforming Materials. In the QCP, specifically address how non-conforming materials will be controlled and identified.

Establish and maintain an effective and positive system for controlling non-conforming material, including procedures for its identification, isolation and disposition. Reclaim or rework non-conforming materials according to procedures acceptable to the Engineer.

Identify all non-conforming materials and products to prevent use, shipment and intermingling with conforming materials and products. Provide holding areas, mutually agreeable to the Engineer and Contractor.

i. Concrete Information. Separately list the grades of concrete involved in the project. For each grade of concrete to be used, include at a minimum, the following:

- Mix designs. List mix design numbers if using existing mixes.
- Aggregate production.
- Quality of components.
- Stockpile management.
- Proportioning, including added water.
- Mixing and transportation.
- Initial mix properties.
- Placement and consolidation.
- Concrete yield.

306.2 CONTRACTOR QC REQUIREMENTS
g. Mix Design

- Mixture Design
 - Aggregates
 - Portland Cement
 - Fly ash
 - Address set time (function of ambient temp)
 - Strength gain (function of ambient temp)
- (1) 7-Day Compressive Strength
- 650 psi minimum
 - 1600 psi Maximum
 - Score/saw joints with higher strengths

306.2 CONTRACTOR QC REQUIREMENTS
g. Mix Design

- (2) Submit single point gradation for combined aggregate with tolerance (SS 1105)

Sieve size	1 1/2"	1/2"	No. 4	No. 8	No. 40	No. 200
Single point	*	*	*	*	*	*
Tolerance	*	+/-*	+/-*	+/-*	+/-*	+/-*

* These values to be established by the Contractor

- (3) Mix batch weights
- Address initial set times
 - Address placement times

306.2 CONTRACTOR QC REQUIREMENTS
g. Mix Design

- (4) Submit Laboratory compressive strength test results: 1 set of 3 plugs. (KT-37)
- (5) Submit test results 2 weeks prior to use.
- Engineer Reviews in 5 Working Days
 - Engineer may do verification testing
- (6) Proposed changes prior to implementing them.

306.2 – Cement Treated Base

Submit (email or fax) copies of all failing test results (based on a moving average of 4 tests, if appropriate) and a summary sheet to the Field Engineer on a daily basis.

File all reports, records, charts and diaries developed during the progress of construction activities. Upon completion of the contract, all documentation becomes the property of KDOT.

f. Testing Requirements. In the QCP, identify test methods, procedures and equipment proposed for use. Use standard KDOT test methods and properly calibrated measuring and testing equipment as outlined in Part V. Detail any alternative sampling method, procedure or inspection equipment proposed to be used. Such alternatives are subject to review and approval by the DME.

Take all samples for tests and perform in-place tests at random locations selected according to the Contractor's QC Plan and at the rates specified in the Sampling and Testing Frequency Chart for Cement Treated Base for Quality Control/Quality Assurance Projects in Appendix B, Part V. Retain the latest 10 gradation samples for use by the Engineer.

Retain the second half of the latest 10 gradation samples for use by the Engineer.

g. Mix Design. Design a mixture of aggregate and portland cement or fly ash, or both. If fly ash is used in the mixture, address the set time and strength gain as a function of the ambient temperature. Design the mixture according to the following requirements:

- (1) The compressive strength shall be between 650 and 1600 psi. Any test correlating to the maximum value or higher requires scoring or sawing joints in the base that fall within the failing test section (from previous to next passing test sections). Determine compressive strength at 7 days, according to Part V.

- (2) Submit a single point gradation for the combined aggregates along with a plus/minus tolerance for each sieve to the Engineer. The plus/minus tolerances shall be used by the Contractor to perform quality control checks and by the Engineer to perform aggregate gradation verification testing. Perform tests on the combined materials.

- (3) Submit the mix batch weights in an acceptable manner to the DME. Address the initial set times (specified in AASHTO T 154) and placement times (with regards to the set times) in the proposed mix design.

- (4) Submit laboratory compressive strength test results on a minimum of 1 set of 3 plugs, produced from the proposed mix design and utilizing the actual materials proposed for use on the contract.

- (5) Submit the test results 2 weeks prior to the anticipated date for using the design on the contract. The Engineer will review the design within 5 working days of receipt. The Engineer may perform any testing necessary to verify the adequacy of the Contractor's design. If the Engineer calls for verification tests, supply the Engineer with the necessary materials to enable the Engineer to test the mix properties within 5 working days of notification.

- (6) Submit any proposed changes to the approved mix design to the DME for approval before implementing the proposed changes.

h. Corrective Action. In the QCP, identify procedures for notifying the Engineer when corrective measures must be implemented, and for halting production.

Notify the Engineer when the moving average test result trend line for any property approaches the specification limits. Cease operations when 2 consecutive moving average points fall outside the specification limits, or 2 consecutive single compressive strength tests exceed the specification limits. Ceasing operations is the Contractor's responsibility. Quality control tests for this determination include aggregate gradation, compliance with the mix design band and in-place density of CTB.

Failure to cease operations for the conditions cited above will subject all subsequent material to rejection, or acceptance at a reduced price, as determined by the Engineer.

The Engineer may examine materials represented by individual test results, which lie beyond the Contractor's normal quality control testing variation. The investigation may be based on either Contractor or KDOT test results. The information from additional testing (including testing of in-place pavement) may be used to define unacceptable work according to SECTION 105. The Engineer will apply appropriate price reductions or initiate corrective action.

•

501.2 CONTRACTOR QC REQUIREMENTS

i. Concrete Information

- Mix designs
- Quality of components
- Proportioning (H₂O)
- Initial Mix Properties
- Concrete Yield
- Finishing and Curing
- Aggregate production
- Stockpile Management
- Mixing and Transportation
- Placement and Consolidation
- Compressive Strength
- Sampling and Testing Frequency

- How Duties and Responsibilities are accomplished and Documented
- Number of CIT Techs required
- Criteria to correct or reject unsatisfactory material

- **501.2 – Portland Cement Concrete Pavement**

i. Concrete Information. Separately list the grades of concrete involved in the project. For each grade of concrete to be used, include at a minimum, the following:

- Mix designs. List mix design numbers if using existing mixes.
- Aggregate production.
- Quality of components.
- Stockpile management.
- Proportioning, including added water.
- Mixing and transportation.
- Initial mix properties.
- Placement and consolidation.
- Concrete yield.
- Compressive strength.
- Finishing and curing.
- Frequency of sampling and testing.
- How duties and responsibilities are to be accomplished and documented, and if more than one Certified Technician is required.
- The criteria used by the Certified Technician to correct or reject unsatisfactory materials.

501.3 MATERIALS

Provide materials that coly with the applicable requirements.

Concrete and Grout	SECTIONS 401& 403
Aggregates for On Grade Concrete	SECTION 1116
Reinforcing Steel	DIVISION 1600
Epoxy Coated Steel Bars for Concrete Reinforcement	DIVISION 1600
Joint Sealants	DIVISION 1500
Expansion Joint Filler	DIVISION 1500
Concrete Curing Materials	DIVISION 1400
Preformed Elastomeric Compression Joint Seals	DIVISION 1500
Cold Applied Chemically Cured Joint Sealant	DIVISION 1500
Hot Type Joint Sealing Compound	DIVISION 1500
Backer Rod	DIVISION 1500
Epoxy Resin-Base Bonding System for Concrete	SECTION 1705
Bond Breakers	SECTION 1718

501.4 CONSTRUCTION REQUIREMENTS

a. Preparation of the Subgrade. Before placing any surfacing material on any section, complete the ditches and drains along that section to effectively drain the highway. Trim the base or subgrade to the line, grade

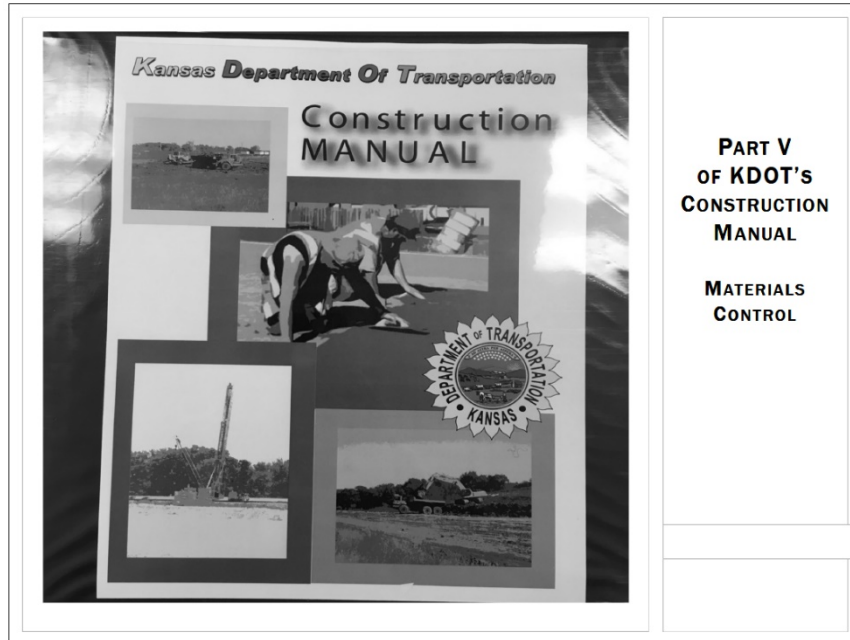

5.2.7.4 Concrete: Contractor's QC Plan

1. General
2. Quality Control Organization
3. Quality Control Plan
 - Submit 30 days before work begins
4. Documentation
5. Corrective Action
6. Non-Conforming Materials
7. Testing Facilities
 - AAP approved Laboratory

5.2.7.4 CONCRETE: CONTRACTOR'S QUALITY CONTROL PLAN

NOTE: This document is generally written in the imperative mood. The subject, "the *Contractor*" is implied. Also implied in this language are "*shall*", "*shall be*", or similar words and phrases. The word "*will*" generally pertains to decisions or actions of the Kansas Department of Transportation.

1. GENERAL

Provide qualified personnel and sufficient equipment meeting the requirements listed in the Department's Construction Manual to conduct quality control testing which conforms with the Sampling and Testing Frequency Chart for Portland Cement Concrete Pavement for Quality Control/Quality Assurance Projects in Appendix B of this Manual.

Calibrate and correlate the testing equipment with prescribed procedures and conduct tests in conformance with specified testing procedures as listed in the Department's Construction Manual. As a minimum, meet the calibration schedule as outlined in **Table 1, Concrete Materials Test Equipment**.

Maintain control charts on an ongoing basis.

File all reports, records, and diaries developed during the progress of construction activities as directed by the Engineer. Files become the property of the Engineer.

Provide the following:

- Make copies of all test results and control charts readily available to the Engineer at the project site.
- Copies of all failing test results (based on a moving average of four tests, when appropriate) and summary sheet sent on a daily basis to the Construction Engineer.

2. QUALITY CONTROL ORGANIZATION

Submit a listing of the names and phone numbers of individuals and alternates responsible for quality control administration and inspection along with the proposed mix design data. Provide an organizational chart that shows the specified lines of authority relating both to mix design and quality control operations during production. Post a copy of the organizational chart in the Contractor's test facility.

The Contractor's quality control organization or private testing firms representing the Contractor must include individuals who are certified by KDOT, or a State approved equivalent, for the appropriate test methods. Only technicians certified in accordance with KDOT requirements may perform process control testing on the project.

3. QUALITY CONTROL PLAN

Prepare a Quality Control Plan detailing the type and frequency of inspection, sampling and testing deemed necessary to measure and control the various properties of materials and construction governed by the Specifications. As a minimum, detail sampling location and techniques, and test frequency to be utilized in the sampling and testing plan. The Department may utilize quality control sampling and testing performed by the Contractor for acceptance. Submit the Quality Control Plan to the Engineer in writing a minimum of 30 days before work begins.

5.2.7.4 Concrete: Contractor's QC Plan

Table 1, Concrete Materials Test Equipment

Equipment – Test Method	Requirements	Interval (months)
Mechanical Shakers – KT-02	Check Sieving Thoroughness	12
General Purpose Balances, Scales and Masses – AASHTO M 231	Calibrate	12
Test Thermometers – KT-17, KT-22 & KT-73	Standardize	12
Compression Testing Machine – KT-22, KT-23, KT-49 & KT-76	Standardize Verify plane of bearing blocks Clean and lubricate upper bearing block	12 12 6
Sieves – AASHTO M 92	Check Physical Conditions	6
Water tanks – AASHTO M 201	Cleaned and refilled with 3 g/L of hydrated lime (calcium hydroxide). Verify recording thermometer.	24 6
Pressure Meter – KT-18	Standardize	3
Volumetric Meter – KT-19	Standardize	12
Slump Cones- KT-21	Check Critical Dimensions	12
Unit Mass – KT-20	Standardize	12
Capping Material – KT-77	Check Strength	3
Reusable Molds – KT-23	Check Critical Dimensions	12
Nuclear Density Gauge – KT-36 & 38	Check for Uniformity	12

5.2.7.5 Example of a Laboratory Quality Manual for Concrete

VERIFICATION PROCEDURE FOR UNIT MASS (Page 1/2)

Purpose:

This method provides instructions for calibrating measures used in obtaining unit mass.

Inspection Equipment Required:

1. Balance conforming to Part V 5.9, Sampling and Test Methods Forward
2. 0.01 in (0.25 mm) feeler gauge.
3. 1/4 in (6 mm) thick glass plate at least 1 in (25 mm) larger than the measure.
4. Water pump or chassis grease.
5. Thermometer.

Tolerance:

The bowls and measures shall conform to the dimensions found in KT-20.

Procedure:

1. Place glass plate on rim and attempt to insert feeler gauge.
2. Fill measure with room temperature water and cover in such a way as to dispel air bubbles and excess water.
3. Determine the mass of water in the measure.
4. Determine the temperature of the water, and obtain its density from KT-15.
5. Calculate the volume, V, of the measure by dividing the mass of the water required to fill the measure by its density.
6. Calculate the factor for the measure (1/V) by dividing the density of the water by the mass required to fill the measure.

5.2.7.5 Example of a Laboratory Quality Manual for Concrete

VERIFICATION RECORD FOR UNIT MASS (Page 2/2)

Verified By: _____ Date: _____

Equipment: Measure for Unit Mass Verif. Frequency: _____

Previous Verif. Date: _____ Next Due Date: _____

Verification Equipment Used: _____

Verif. Equipment Identification: _____

Verif. Procedure Used: _____

	Specification
Glass 6 mm thick and 25 mm larger than measure	Yes / no
Rim plane to 0.25 mm	Yes / no
Temperature of water taken	Yes / no
Density obtained KT 20	Yes / no
Volume and measure factor determined	Yes / no
Action recommended	Yes / no

5.2.7.4 Concrete: Contractor's QC Plan
5.2.7.8 CTB: Contractor's QC Plan

8. Testing Requirements

- Plotting Control Charts
- Individual Test Results – Black Pen
- Connect with a solid black line _____
- Moving Average Values – Red Pen
- Connect with a red dash line - - - - -
- KDOT's verification results – Green *
- Working Range Limits (single) – Dotted Green Line
- 4-Point Moving Average limits – Solid Green Line _____

5.2.7.4 Concrete: Contractor's QC Plan
Control Chart

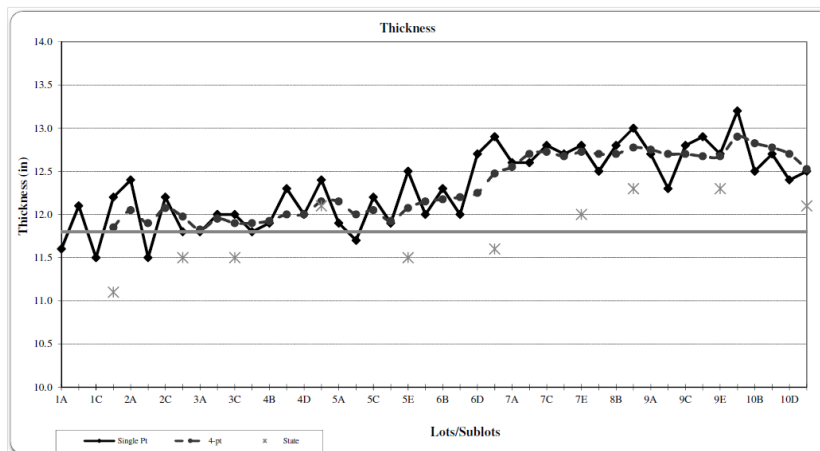

Table 1, Concrete Materials Test Equipment

Equipment – Test Method	Requirements	Interval (months)
Mechanical Shakers – KT-02	Check Sieving Thoroughness.	12
General Purpose Balances, Scales and Masses – AASHTO M 231	Calibrate	12
Test Thermometers – KT-17, KT-22 & KT-73	Standardize	12
Compression Testing Machine – KT-22, KT-23, KT-49 & KT-76	Standardize	12
	Verify plane of bearing blocks	12
	Clean and lubricate upper bearing block	6
Sieves – AASHTO M 92	Check Physical Conditions.	6
Water tanks – AASHTO M 201	Cleaned and refilled with 3 g/L of hydrated lime (calcium hydroxide).	24
	Verify recording thermometer.	6
Pressure Meter – KT-18	Standardize	3
Volumetric Meter – KT-19	Standardize	12
Slump Cones- KT-21	Check Critical Dimensions.	12
Unit Mass – KT-20	Standardize	12
Capping Material – KT-77	Check Strength.	3
Reusable Molds – KT-23	Check Critical Dimensions.	12
Nuclear Density Gauge – KT-36 & 38	Check for Uniformity	12

8. Testing Requirements. Take all samples for tests at random locations, selected as specified in the Contractor’s quality control plan and at the rates specified in the Sampling and Testing Frequency Chart for Portland Cement Concrete Pavement for Quality Control/Quality Assurance Projects in Appendix B-of Part V of this manual. Record and document all test results and calculations on data sheets that are acceptable to the Engineer. Record specific test results on a daily summary sheet approved by the Engineer to facilitate the computation of moving test averages. Base moving averages on 4 consecutive test results. Include a description of quality control actions taken (adjustment of aggregate or additive proportions in the mix, moisture adjustments, etc.) in the Daily Quality Control Summary Sheet. Post quality control charts and keep current, show both individual test results and moving average values. Plot the single test values and the 4 test moving average values on approved control charts.

Plot individual test results in black for each test point. Connect points with a solid black line. Plot the moving average for each test variable in red starting with the fourth test. Connect the points with a dashed red line. Plot the Department's verification test results with green asterisks. Do not include the Department's verification tests in the moving average.

Indicate specification working range limits for single test results on the control charts using a dotted green line and for four point moving average results with a solid green line.

NOTE: Section 5.2.7.5 of this manual, Example of a Laboratories Quality Manual, will provide examples of equipment procedures to verify that equipment is in proper condition. Also, examples of records for calibrating/verifying equipment are presented.

5.2.7.8 Cement Treated Base: Contractor's QC Plan

1. General
2. Quality Control Organization
3. Quality Control Plan
 - Submit 30 days before work begins
4. Documentation
5. Corrective Action
6. Non-Conforming Materials
7. Testing Facilities
 - AAP approved Laboratory

5.2.7.8 CTB: Contractor's QC Plan Table 1, CTB Materials Test Equipment

Equipment – Test Method	Requirements	Interval (months)
Mechanical Shakers – KT-02	Check Sieving Thoroughness	12
General Purpose Balances, Scales and Masses – AASHTO M 231	Calibrate	12
Compression Testing Machine – KT-22, KT-23, & KT-76	Standardize	12
	Verify plane of bearing blocks	12
	Clean and lubricate upper bearing block	6
Sieves – AASHTO M 92	Check Physical Conditions	6
Slump Cones- KT-21	Check Critical Dimensions	12
Unit Mass – KT-20	Standardize	12
Capping Material – KT-77	Check Strength	3
Reusable Molds – KT-37	Calibrate	12
Nuclear Density Gauge – KT-36 & 38	Check for Uniformity	12
Ovens	Calibrate	12
Thermometers	Calibrate	12

5.2.7.8 CEMENT TREATED BASE: CONTRACTOR'S QUALITY CONTROL PLAN (CTB)

NOTE: This document is generally written in the imperative mood. The subject, "the *Contractor*" is implied. Also implied in this language are "*shall*", "*shall be*", or similar words and phrases. The word "*will*" generally pertains to decisions or actions of the Kansas Department of Transportation.

1. GENERAL

Provide qualified personnel and equipment meeting the requirements listed in the Department's Construction Manual to conduct quality control testing which conforms with the Sampling and Testing Frequency Chart for Cement Treated Base for Quality Control/Quality Assurance Projects in Appendix B of this Manual.

Calibrate and correlate the testing equipment with prescribed procedures and conduct tests in conformance with specified testing procedures as listed in the Department's Construction Manual. As a minimum, meet the calibration schedule as outlined in **Table 1, Cement Treated Base Materials Test Equipment**.

Maintain control charts on an ongoing basis.

File all reports, records, and diaries developed during the progress of construction activities as directed by the Engineer. Files become the property of the Department.

Provide the following:

- Make copies of all test results and control charts readily available to the Engineer at the project site.
- Copies of all failing test results (based on a moving average of four tests, when appropriate) and summary sheet sent by on a daily basis to the Construction Engineer.

2. QUALITY CONTROL ORGANIZATION

Submit a listing of the names and phone numbers of individuals and alternates responsible for quality control administration and inspection along with the proposed mix design data. Provide an organizational chart that shows the specified lines of authority relating both to mix design and quality control operations during production. Post a copy of the organizational chart in the Contractor's test facility.

The Contractor's quality control organization or private testing firms representing the Contractor must include individuals who are certified by KDOT, or a State approved equivalent, for the appropriate test methods. Only technicians certified in accordance with KDOT requirements may perform process control testing on the project.

3. QUALITY CONTROL PLAN

Prepare a Quality Control Plan detailing the type and frequency of inspection, sampling and testing deemed necessary to measure and control the various properties of materials and construction governed by the Specifications. As a minimum, detail sampling location and techniques, and test frequency to be utilized in the sampling and testing plan. The Department may utilize quality control sampling and testing performed by the Contractor for acceptance. Submit the Quality Control Plan to the Engineer in writing a minimum of 30 days before work begins.

**Appendix B
Sampling and Testing Frequency Chart
Contractor Quality Control Testing**

**Sampling and Testing
Frequency Chart
(STFC)**

Located in
Part V of the Construction Manual,
Appendix B (2015)

**Appendix B
Sampling and Testing Frequency Chart
Contractor Quality Control Testing**

GENERAL NOTES

- All sampling and testing frequencies listed are minimums. Additional quality control, verification, and assurance tests will be performed, when necessary, to provide effective control the work. When any quality control test result fails to comply with the specification requirements then the next subplot of production after obtaining the failing test results will be sampled and tested, regardless of any lesser frequency specified in this appendix.
- For the Construction Management System (CMS), Acceptance Sampling and Tests have been divided into two sections. Items called "ACC" will be Acceptance Tests and will have a quantity assigned. Items called "ACT" will be Acceptance Information Tests and they will normally have a quantity assigned, but not for payment. "ACC" tests make the assignment of tested materials to the contract or mix plant. "Type Insp" must = "ACC" when assignment of a pay quantity is being made. "ACT" when recording test values for additional acceptance information.
- For QUALITY CONTROL BY CONTRACTOR, CMS uses ACT or ACC unless otherwise noted. For VERIFICATION BY KDOT, CMS uses VER unless otherwise noted. For INDEPENDENT ASSURANCE BY KDOT, CMS uses ASW (Assurance Witness), ASR (Assurance Replicate), and ASP (Assurance Split) unless otherwise noted (see section 5.8.2 of this manual).
- For a better explanation of metric (SI) units, see section 5.9, "Sampling and Test Methods Forward", of this manual.
- All samples will be taken from the place of incorporation into the project unless otherwise noted.

First General Note:

- Sampling and testing frequencies are minimums.
- Additional testing when necessary to provide better control
- If QC, QA or IA test fails, then sample and test in next subplot.

**Appendix B
Sampling and Testing Frequency Chart
Contractor Quality Control Testing**

CODE

INSTRUCTION

- a The contractor may reduce the sampling and testing frequency to one test per 1,000 yd³ (1,000 m³) provided the first two tests each day show compliance with the specification requirements.
- c The aggregate producer's tests may be used for quality control purposes if the tests were performed by an appropriately certified technician. In such cases, the contractor shall perform testing as necessary to determine the degrading effects of hauling and stockpiling on the individual aggregates. For CTB, the minimum testing frequency shall be every 4,000 Tons (4,000 Mg).
- h If during the determination of individual aggregate gradation, clay lumps and soft or friable particles, shale or shale-like particles, or sticks are found then perform KT-7, KT-8, and KT-35, respectively, at such frequencies as jointly deemed necessary by the Contractor and the District Materials Engineer.
- k Engineer's discretion. Frequency of tests shall be agreed upon by the Field Engineer and the District Materials Engineer. Frequency will be governed by field conditions. Written documentation of the agreed upon testing frequency shall be included in the project records.
- m The contractor may reduce the sampling and testing frequency to one test per 2,000 Tons (2,000 Mg) provided the first ten tests show compliance with the specification requirements.
- o Verification method must be the same test method as used for mix design approval.
- p Frequency may be reduced to 1 pre-production verification test per day provided the following are met: 1) Handheld moisture meter is used at least once per every 50 cubic yards of production. 2) The meter has an accuracy of ±0.5% of the pre-production verification test. 3) Moistures obtained from the meter are used to adjust batch-to-batch moisture corrections.

**SAMPLING AND TESTING FREQUENCY CHART
QUALITY CONTROL/QUALITY ASSURANCE SPECIFICATIONS**

<u>CODE</u>	<u>INSTRUCTION</u>
a	The contractor may reduce the sampling and testing frequency to one test per 1,000 yd ³ (1,000 m ³) provided the first two tests each day show compliance with the specification requirements.
b	Sampled by the district field personnel, or contractor and tested at KDOT Central Materials Laboratory (Materials and Research Center).
c	The aggregate producer's tests may be used for quality control purposes if the tests were performed by an appropriately certified technician. In such cases, the contractor shall perform testing as necessary to determine the degrading effects of hauling and stockpiling on the individual aggregates. For CTB, the minimum testing frequency shall be every 4,000 Tons (4,000 Mg).
d	At least one Modified Lottman test is required weekly. When more than 10,000 Tons (10,000 Mg) of production occurs in a week, then run additional tests to meet the requirement of 1 test per 10,000 Tons (10,000 Mg).
e	Specification compliance will be determined on a producer basis not on a project basis. Producer and product testing frequency is maintained in CMS. Start with one in three loads, then generally, the sampling frequency will be reduced to one sample per six loads and then per twelve loads if test results determined by the Department show satisfactory compliance of the material with the specifications.
f	Determine the Sand Equivalent (SE) value on the combined virgin aggregates on the first lot of production and then frequency may be reduced to one test per week provided the SE value exceeds the minimum specified value by five (5) percentage points. The frequency may be reduced to one test per two weeks provided the SE value exceeds the minimum specified value by 25 percentage points. When any test (including verification and assurance) shows the SE value to be less than five (5) percentage points above the specified minimum value then the testing frequency will revert to one per lot until two consecutive tests exceed the minimum specified value by five (5) percentage points.
g	All aggregate types except siliceous gravels and steel slag will be considered to have at least two crushed faces on 100% of the aggregate particles. For mixes containing crushed or uncrushed siliceous gravels or steel slag, determine the Coarse Aggregate Angularity (CAA) value of the combined virgin aggregate of the first lot of production. After three consecutive passing tests, the frequency may be reduced to one per three lots or one per week. If any of the quality control or verification tests fail, the frequency will revert to one per lot until the above criteria for reduced frequency is met.
h	If during the determination of individual aggregate gradation, clay lumps and soft or friable particles, shale or shale-like particles, or sticks are found then perform KT-7, K T-8, and KT-35, respectively, at such frequencies as jointly deemed necessary by the Contractor and the District Materials Engineer.
i	For small lots [lots with less than 1,000 tons (1,000 Mg)], the number of tests may be reduced (see special provision).
j	Provide access to Contractor owned forced air ignition furnace, ovens, and Superpave Gyrotory compactor, as required, for the State Inspector to perform verification tests.
k	Engineer's discretion. Frequency of tests shall be agreed upon by the Field Engineer and the District Materials Engineer. Frequency will be governed by field conditions. Written documentation of the agreed upon testing frequency shall be included in the project records.
l	This testing of crushed gravel is only needed to confirm that 35% or less natural sand is used in the traveled way mixes. If 95% or more of crushed gravel is retained on the #8 (2.65 mm) sieve, then the material must have a minimum Uncompacted Void Content of Coarse Aggregate (UVA) value of 45 when tested in accordance with KT-80. Test at the same frequency as KT-50. Do not use material with a UVA value less than 45.
m	The contractor may reduce the sampling and testing frequency to one test per 2,000 Tons (2,000 Mg) provided the first ten tests show compliance with the specification requirements.
n	If more than one test is performed on the sample, use the average value.
o	Verification method must be the same test method as used for mix design approval.
p	Frequency may be reduced to 1 pre-production verification test per day provided the following are met: 1) Handheld moisture meter is used at least once per every 50 cubic yards of production. 2) The meter has an accuracy of ±0.5% of the pre-production verification test. 3) Moistures obtained from the meter are used to adjust batch-to-batch moisture corrections.

GENERAL NOTES

- All sampling and testing frequencies listed are minimums. Additional quality control, verification, and assurance tests will be performed, when necessary, to provide effective control the work. When any quality control test result fails to comply with the specification requirements then the next subplot of production after obtaining the failing test results will be sampled and tested, regardless of any lesser frequency specified in this appendix.
- For the Construction Management System (CMS), Acceptance Sampling and Tests have been divided into two sections. Items called "ACC" will be Acceptance Tests and will have a quantity assigned. Items called "ACT" will be Acceptance Information Tests and they will normally have a quantity assigned, but not for payment. "ACC" tests make the assignment of tested materials to the contract or mix plant. "Type Insp" must = "ACC" when assignment of a pay quantity is being made. "ACT" when recording test values for additional acceptance information.
- For QUALITY CONTROL BY CONTRACTOR, CMS uses ACI or ACC unless otherwise noted. For VERIFICATION BY KDOT, CMS uses VER unless otherwise noted. For INDEPENDENT ASSURANCE BY KDOT, CMS uses ASW (Assurance Witness), ASR (Assurance Replicate), and ASP (Assurance Split) unless otherwise noted (see section 5.4.2 of this manual).
- For a better explanation of metric (SI) units, see section 5.9, "Sampling and Test Methods Forward", of this manual.
- All samples will be taken from the place of incorporation into the project unless otherwise noted.

**SAMPLING AND TESTING FREQUENCY CHART
CONTRACTOR QUALITY CONTROL TESTING**

CONSTRUCTION OR MATERIAL TYPE 2015 Std. Spec. (SS 2015)	TESTS REQUIRED (RECORDED TO)	TEST METHOD	CODE	QUALITY CONTROL BY CONTRACTOR	CODE	VERIFICATION BY KDOT
DIVISION 300						
CEMENT TREATED BASE (CTB) Sec. 306 & 1105	Sieve Analysis of Aggregate (1%, 0.1% for No. 200 [75 µm] sieve, of mass)	KT-02	c h	1 per day.		1 per week.
	Moisture Tests (0.1 g or 0.01% of mass)	KT-11 or KT-41		4 per day per design.		1 per week.
	Density (0.1 lb/ft ³ [1 kg/m ³] or 0.1% of optimum density)	KT-37 or KT-20*		1 per day per design (* KT-20 option is only permitted in conjunction with a fluid mix.)		1 per project per design.
	Compressive Strength (1 psi [0.01 MPa])	KT-37		1 specimen per subplot		1 specimen per lot.
Completed Base	Field Density Tests (0.1 lb/ft ³ [1 kg/m ³] or 0.1% of optimum density)	KT-13 or KT-41		4 per day per design.		1 per week per design.
	Moisture Tests (0.1 g or 0.01% of mass)	KT-11 or KT-41		4 per day per design.		1 per week per design.
DIVISION 500						
PORTLAND CEMENT CONCRETE PAVEMENT Sec. 501 & 503 Individual Aggregates	Sieve Analysis of Aggregate (1%, 0.1% for No. 200 [75 µm] sieve, of mass)	KT-02	c m	1 per 500 TONS (500 Mg) of combined aggregate.		1 per project.
	Clay Lumps and Friable Particles in Aggregate (0.1 g or 0.01% of mass)	KT-07	c h			As required.

**SAMPLING AND TESTING FREQUENCY CHART
CONTRACTOR QUALITY CONTROL TESTING**

CONSTRUCTION OR MATERIAL TYPE 2015 Std. Spec. (SS 2015)	TESTS REQUIRED (RECORDED TO)	TEST METHOD	CODE	QUALITY CONTROL BY CONTRACTOR	CODE	VERIFICATION BY KDOT
DIVISION 500 (continued)						
PORTLAND CEMENT CONCRETE PAVEMENT Sec. 501 & 503 (continued) Individual Aggregates (continued)	Shale or Shale-Like Materials in Aggregate (0.1 g or 0.01% of mass)	KT-08	c h			As required.
	Sticks in Aggregate (0.01% of mass)	KT-35	c h			As required.
	Unit Weight – lightweight aggregates only (0.1 lb [50 g] or 0.1% of mass)	KT-05	c k			As required.
	Moisture in Aggregate (0.1 g or 0.01% of mass)	KT-24	p	1 per 1/2 day.		1 per week.
	Coal	AASHTO T 113				As required.
	Organic Impurities	AASHTO T 21				As required.
	Concrete	Mass per cubic foot (0.1 lb/ft ³ [1 kg/m ³])	KT-20	a	1 per 500 yd ³ (500 m ³).	
Slump (0.25 in [5 mm])		KT-21	a	1 per 500 yd ³ (500 m ³).		1 per day.
Temperature (1 °F [0.5 °C])		KT-17	a	1 per 500 yd ³ (500 m ³).		1 per day.

**SAMPLING AND TESTING FREQUENCY CHART
CONTRACTOR QUALITY CONTROL TESTING**

CONSTRUCTION OR MATERIAL TYPE 2015 Std. Spec. (SS 2015)	TESTS REQUIRED (RECORDED TO)	TEST METHOD	CODE	QUALITY CONTROL BY CONTRACTOR	CODE	VERIFICATION BY KDOT
DIVISION 500 (continued)						
PORTLAND CEMENT CONCRETE PAVEMENT Sec. 501 & 503 (continued) Concrete (continued)	Air Content (0.25%)	KT-18 or KT-19	a	1 per 500 yd ³ (500 m ³) or every 2 hours (mainline), every 4 hours (other slipformed pvmt), whichever is more frequent. Determine the air loss due to paving operations once in the AM and once in the PM. Determine the difference between the air content from concrete sampled before the paver, and concrete sampled behind the paver.		1 per day.
	Density of Fresh Concrete (0.1 lb/ft ³ [1 kg/m ³])	KT-38		Initially, 1 complete transverse profile, then 1 density per ½ day.		1 density per week.
	Beams (1 psi [1 kPa])	KT-22 & KT-23		1 set of 3 as required for opening to traffic.		1 set of 3 per week as required for opening to traffic.
	Cores (1 lbf [1 N], 0.01 in [1 mm], 1 psi [0.01 MPa])	KT-49		As required in SS 2015 section 501.5g.		Thickness measurement and compression test – 1 per lot.

**SAMPLING AND TESTING FREQUENCY CHART
CONTRACTOR QUALITY CONTROL TESTING**

CONSTRUCTION OR MATERIAL TYPE 2015 Std. Spec. (SS 2015)	TESTS REQUIRED (RECORDED TO)	TEST METHOD	CODE	QUALITY CONTROL BY CONTRACTOR	CODE	VERIFICATION BY KDOT
DIVISION 500 (continued)						
PORTLAND CEMENT CONCRETE PAVEMENT Sec. 501 & 503 (continued) Concrete (continued)	Air Void Analyzer (0.0001 in [0.001 mm])	KT-71		Prequalification of mix required as per SS 2015 sec. 403.4.		1 test randomly during every 4 weeks of production.
	Permeability (0.01%, KT-73; 10 coulomb, AASHTO T 277; nearest 0.1 kΩ-cm, KT-79)	KT-73 or AASHTO T 277 or KT-79	o			1 per mix design per project.
	Profilograph	KT-46		2 tracks per 12 ft (3.7 m) of width for the full length of the project.		At the Engineer's discretion.
	Vibrator Frequency Per Standard Specification 154.2e	SS 154.2e		Every 4 hours		Daily
ON-GRADE CONCRETE (OGCA)						See 5.6 Section 5.4.4 of this manual.

CIT Manual

<https://www.ksdot.org/Assets/wwwksdotorg/bureaus/burConsMain/CIT%20Manual%202016%20revision%20official.pdf>



Policy and Procedure Manual for The Certified Inspection and Testing Training (CIT) Program

Rev. 2016

TABLE OF CONTENTS

CIT TRAINING OVERVIEW	2
REGISTRATION PROCESS	4
CERTIFICATION PROCESS	4
QUIZ OUT	6
RECERTIFICATION	7
BASIC INSPECTION COURSE, EXAMS AND RECERTIFICATION EXAMS	10
DISQUALIFICATIONS	10
REPORTING INFRACTIONS	12
INVESTIGATION	13
REVIEW COMMITTEE	13
APPEALS COMMITTEE	14
PROGRAM ADMINISTRATION	15
APPENDIX A - ABBREVIATIONS	17
APPENDIX B - COURSE SUMMARIES	18

CIT Manual Certification Process

a. General

When Sampling and Testing is required by
- Construction Contract Documents
- Consultant Inspection Agreements
Then must be performed by Qualified
Technicians

Students become qualified by:

- Passing written exam for each classification
- Passing test demonstrating skill and competence

CIT Manual Certification Process

Maintain your Qualifications by Correctly:

- Sampling
- Testing
- Recordkeeping Obligations
- Periodic Renewal

CIT Manual Disqualifications

a. Immediate Disqualification

- alleged infraction poses an imminent danger to public health, safety or welfare
- Sole Discretion of the Chief Bureau of Construction and Materials

b. Cheating on Any Examination

c. Other Infractions (11 listed)

- Using incorrect or damaged test equipment
- Incorrect sampling and testing procedures
- Submitting fraudulent test results
- Submitting test reports not signed by certified personnel

CIT Manual Recertification

- Most Certifications valid for five (5) years
- Must renew prior to expiration date
- Individual is responsibility for renewal
- Failure to recertify prior to expiration date
 - Results in decertification
 - Once expired, Technician cannot Sample and Test for that area

Notice will NOT be sent when a technician allows any certification to lapse or expire

REVIEW

Who Does Quality Control?

Who Does Quality Verification?

Who Does Independent Assurance?

Why do we Sample, Test, and Inspect?

Who's Responsible for the Contractor's Equipment Calibrations?

REVIEW

Who is responsible for maintaining the technicians certification?

If a technician's certification expires, is he able to continue testing in that specialty area?

Which two individuals need to be identified in the contractor's QC Plan for either PCCP or CTB?

REVIEW

Where is the Sampling and Testing Frequency Chart?

Can the Contractor Test more often than what is listed in the STFC?

Can KDOT Test more often than what is listed in the STFC?

SECTION 306 CEMENT TREATED BASE



Cement Treated Base

- 306.1 Description (300-15)
- 306.2 Contractor QC Requirements (300-15)
- 306.3 Materials (300-18)
- 306.4 Construction Requirements (300-18)
- 306.5 Measurement and Payment (300-21)



Section 306
Cement Treated Base

- **QC for CTB only if QC for PCCP**
- When not QC/QA for CTB, then exclude:
 - 306.2 – Contractor Quality Control Requirements
- And the following are not applicable to the contract:
 - 306.4d – Compaction Determination
 - 306.4g – Compressive Strength Determination



Section 306
Cement Treated Base

Section 306.1 - Description

- Design a CTB mixture
- Construct 1 or more courses of CTB on the prepared roadway

Bid Items

Units

Cement Treated Base

Square Yard

Quality Control Testing (CTB)

Square Yard

SECTION 306

CEMENT TREATED BASE

Exception: If the PCCP in the contract is not specified as QC/QA, (Bid item Quality Control Testing (CTB) is not included as a bid item) subsections 306.2 (entire subsection), 306.4d. and 306.4g. of this SECTION are not applicable to the contract.

306.1 DESCRIPTION

Design a cement treated base (CTB) mixture meeting the requirements of the Contract Documents. Construct 1 or more courses of the CTB on a prepared roadway as shown in the Contract Documents.

BID ITEMS

Cement Treated Base
Quality Control Testing (CTB)

UNITS

Square Yard
Square Yard

306.2 CONTRACTOR QUALITY CONTROL REQUIREMENTS

a. General. Provide qualified personnel and sufficient equipment complying with the requirements listed in Part V to conduct quality control testing that complies with Appendix B, Sampling and Testing Frequency Chart for Concrete Construction Items for Quality Control/Quality Assurance Projects.

Allow the Engineer access to the Contractor's laboratory to observe testing procedures, calculations, test documentation and plotting of test results.

Calibrate and correlate the testing equipment with prescribed procedures, and conduct tests in compliance with specified testing procedures as listed in Part V.

Maintain a Quality Manual in the field laboratory showing the calibrations performed on all test equipment and when the next calibration is due for that equipment. As a minimum, follow the calibration/verification interval established in Table 1: Concrete Materials Test Equipment in Section 5.2.7.8-Cement Treated Base: Contractor's Quality Control Plan (CTB), Part V. See also, Part V Section 5.2.7.8.1-Example of a Laboratory Quality Manual for CTB.

Provide personnel and equipment to conduct quality control testing that complies with the Contract Documents. Provide certified technicians to perform process control testing. Use equipment that complies with, and is calibrated according to the specified test methods.

b. Quality Control Plan (QCP). At the pre-construction conference, submit to the Engineer for approval by the DME, a QCP as outlined in Section 5.2.7-Contractor's Quality Control Plan, Part V. Follow 5.2.7.8-Cement Treated Base: Contractor's Quality Control Plan in Part V as a general guideline. Keep a printed copy of the approved QCP in the Contractor's laboratory and make available to the Engineer when requested.

The Contractor's laboratory and equipment will be inspected and approved as outlined in Part V, Section 5.2.7-Contractor's Quality Control Plan.

Include a listing of the names and phone numbers of individuals and alternates responsible for quality control administration and inspection. On the Contractor's organizational chart, show the specified lines of authority relating both to mix design and quality control operations during production. Post the organizational chart in the Contractor's test facility.

Provide a quality control organization or private testing firm having personnel certified according to the Policy and Procedures Manual for The Certified Inspection and Testing (CIT) Training Program. The testing for this type of construction will require personnel certified in ACI Concrete Field Testing Technician (CF), Aggregate Field Tester (AGF), Soils Field Tester (SOF) and Nuclear Moisture Density Gauge Tester (NUC) classifications. Only persons certified in the appropriate classifications covering the specific tests required shall perform such testing. Provide a minimum of 1 employee on the project certified in the QC/QA Concrete/Cement Treated Base Specs (QCS) classification.

Only persons certified in the appropriate classifications covering the specific tests required shall perform such testing. At the beginning of the project, provide the Engineer with the list of certified technicians and



306.3 Materials

Material	Division
Concrete Admixtures and Curing Material	1400
Portland Cement and Fly Ash	2000
Water for CTB	2400
Aggregates for CTB	1100



a. Subgrade Preparation

- Before placing any CTB material, complete the ditches and drains along the section.
- Use automatically controlled equipment.
- Maintain subgrade as prepared.
- Ensure proper drainage.
- Protect from damage during operations.
- Do not store or stockpile materials on subgrade.
- Do not place CTB on frozen subgrade.
- Moisten subgrade surface before spreading.



b. Mixing the Materials

- Engineer must review and approve mix.
- Plant mix materials according to the approved mix design.
- Use a Batch Mixer or Pugmill to produce a homogeneous mixture.
- Do not use frozen aggregate.
- Take all compressive strength samples at the plant site.
- Compact prior to initial set.



c. Spreading and Compacting

- Maximum single lift is 6 inches (compacted).
- Plan thickness > 6"
 - Spread and Compact in multiple lifts
 - Lifts of equal thickness
 - Offset Longitudinal Joint by at least 6"
 - Keep surface of each lift moist
 - Complete all lifts in same day
- Compact each lift to 95% Standard Density
- Compact within the shorter time of the following:
 - Within 2 hours from time water and cementitious are added to aggregate.
 - Before mix reaches initial set



d. Compaction Determination

- Determine Dry Density and Moisture Content
 - Stiff Mix (can be slip-formed)
 - Fluid Mix (requires forming)

i. Non-Conforming Materials. In the QCP, specifically address how non-conforming materials will be controlled and identified.

Establish and maintain an effective and positive system for controlling non-conforming material, including procedures for its identification, isolation and disposition. Reclaim or rework non-conforming materials according to procedures acceptable to the Engineer.

Identify all non-conforming materials and products to prevent use, shipment and intermingling with conforming materials and products. Provide holding areas, mutually agreeable to the Engineer and Contractor.

The Engineer will determine if reclaiming or reworking of non-conforming materials is allowed.

306.3 MATERIALS

Provide materials that comply with the applicable requirements.

Concrete Admixtures & Curing Material	DIVISION 1400
Portland Cement and Fly Ash	DIVISION 2000
Water for CTB	DIVISION 2400
Aggregates for CTB	DIVISION 1100

306.4 CONSTRUCTION REQUIREMENTS

a. Preparation and Maintenance of the Subgrade. Before placing any CTB material on any section, complete the ditches and drains along that section to effectively drain the highway. Use automatic grade control equipment to trim the surface of the subgrade to the line, grade and cross-section as shown in the Contract Documents. Maintain the subgrade to the as-constructed condition under other contract bid items, repairing any encountered defects to the specifications of the previous bid items. Maintain the subgrade surface to readily drain at all times. Protect the subgrade from damage when handling materials, tools and equipment. Do not store or stockpile materials on the subgrade. Do not place material or lay CTB on a frozen or muddy subgrade.

Lightly spray the subgrade with water to obtain a thoroughly moistened condition before the CTB is placed. Do not puddle water on the grade.

Do not place CTB on frozen subgrade. Do not deposit any material until the subgrade or base has been checked and approved by the Engineer.

b. Mixing the Materials. Do not place CTB on the project until the Engineer has reviewed and approved the submitted mix design.

Plant mix the aggregate, cementing agent and water according to the approved mix design.

Control the charge in a batch mixer, or the rate of feed to a continuous mixer (pugmill), to allow complete mixing of all the materials. Mix the materials to produce a homogeneous mixture. Do not use frozen aggregate.

Take all compressive strength samples at the plant site. Compact the samples prior to the CTB reaching its initial set.

c. Spreading and Compacting the CTB. The maximum compacted thickness of a single lift is 6 inches. If the thickness is greater than 6 inches, spread and compact the subgrade in multiple lifts of equal thickness with a maximum lift thickness of 6 inches. If the base is spread in multiple lifts, offset the longitudinal joints by at least 6 inches.

If multiple lifts are placed, keep the surface of each lift moist until the succeeding lift is spread. Cover the exposed lower lift with the final lift the same day the lower lift is placed.

Compact each lift of CTB to a minimum of 95% of the standard density.

Compact the CTB within 2 hours from the time the water and cementing agent is added to the aggregate, or before the mixture reaches the initial set, whichever is the shorter timeframe.

d. Compaction Determination. Determine dry density and moisture content according to Part V.



d. Compaction Determination

- Determine Dry Density and Moisture Content

Stiff Mixes

Can be Slip Formed
Standard Density by
KT-37 (Proctor)
1 per day

Moisture Content by
KT-11 – 4 per day

Average 3 most recent
tests

Fluid Mixes

Requires Forming
Standard Dry Density by
KT-20 (unit Weight Test)
1 per day

Moisture Content by
KT-11 – 4 per day

Average 3 most recent
tests

Equation 1: Standard Dry Density =
$$\frac{WetDensity}{1 + \left(\frac{\%Moisture}{100}\right)}$$



Appendix B

SAMPLING AND TESTING FREQUENCY CHART
CONTRACTOR QUALITY CONTROL TESTING

CONSTRUCTION OR MATERIAL TYPE (2015 Std. Spec. 608-2015)	TESTS REQUIRED (RECORDED TO)	TEST METHOD	CODE	QUALITY CONTROL BY CONTRACTOR	CODE	VERIFICATION BY KDOT
DIVISION 200						
CEMENT TREATED BASE (CTB) Sec. 206 & 1105	Sieve Analysis of Aggregate (1% to 1% for No. 200 [75 µm])	KT-2	c	1 per day.		1 per week.
	Moisture Tests (at least 0.1% of moist)	KT-11 or KT-41		1 per day per design.		1 per week.
	Density (0.1 lb/ft ³ [1 kg/m ³] or 0.1% of optimum density)	KT-37 or KT-20*		1 per day per design.		1 per project per design.
	Compressive Strength (1 psi [0.01 MPa])	KT-37		4 sets of three for each normal day's production. One set per lot.		1 specimen for each day's production.
Completed Base	Field Density Tests (0.1 lb/ft ³ [1 kg/m ³] or 0.1% of optimum density)	KT-13 or KT-41		1 per day per design.		1 per week per design.
	Moisture Tests (at least 0.1% of moist)	KT-11 or KT-41		1 per day per design.		1 per week per design.

Does it make sense to have Moisture Tests listed twice?



Field Density Methods

- KT-13

Sand Density



Sand Cone



Rubber-Balloon Density



- KT-41 - Nuclear Density Gage



d. Compaction Determination

- Determine the density of the CTB within 1 day of the compaction operations.
- Engineer will verify the Contractor's density test results by conducting density tests at random.
- If comparison is not favorable, DME will investigate to determine cause, and may suspend production until corrective action is taken.

If the mix is stiff (can be slip-formed), determine the standard density by averaging the 3 most recent field molded densities using plant mixed base material. Compact one standard mold (using plant mixed material with the proper moisture content) for each day's operation as specified in KT-37.

If the mix is fluid (requires forming), determine the Standard Dry Density by averaging the 3 most recent consolidated unit weight test results (KT-20). It will be necessary to convert the unit weight (wet density) into a standard dry density which also requires the percent of moisture (KT-11 (4)) to be known. Use Equation 1 to determine the standard dry density.

$$\text{Equation 1: Standard Dry Density} = \frac{\text{Wet Density}}{(1 + [\% \text{Moisture} / 100])}$$

Determine the density of the CTB within 1 day of the compaction operations. The Engineer may verify the Contractor's density test results by conducting density tests at random. If the comparison is not favorable, the DME will investigate to determine the cause and may suspend production until corrective action is taken.

e. Trimming and Finishing the CTB. Trim and recompact the CTB within 2½ hours of the time the water and cementing agent is added to the aggregate.

Trim and compact the CTB to the grades, lines and typical cross sections shown in the Contract Documents. Dress the edge slopes and joints between sections.

Use automatic grade control equipment to trim the surface of the CTB to line grade and cross section.

Keep the surface of the CTB moist during all finishing operations.

Perform the finishing and compacting operations to produce a smooth, dense surface, free of surface compaction planes, cracks, ridges or loose material.

If required, lightly scarify the surface of the CTB to loosen any imprints left by the trimming and compacting equipment. Recompact the surface of the CTB.

At the end of each day's operations, construct a straight transverse construction joint by cutting back into the completed work to form a vertical face. Place a protective covering of earth on the newly constructed CTB a distance back of the joint for turning of equipment used on the following day's work.

Upon satisfactory performance, the Engineer may approve the use of equipment that combines the placing, compacting and finishing operations.

f. Protection and Curing. Keep the surface of the CTB moist until the curing material is applied. Apply the curing material immediately after completing the trimming and finishing. Protect the CTB against the loss of moisture for a curing period of 7 days (unless the Contractor's mix design test results justify a different curing period). Protect the CTB against freezing during the curing period.

Apply a wax-based liquid membrane-forming compound for the curing material. The minimum application rate for wax-based liquid membrane-forming compound is 0.12 gallons per square yard. Use an enclosed spray system that minimizes wind influence and obtains the proper application rate. Keep all traffic and construction equipment off the CTB. The only exception is the equipment used to apply the curing material. Cover the surface and edges of the CTB with a complete, uniform coverage. Use a hand sprayer in inaccessible areas.

If the wax-based liquid membrane-forming compound will be in place for more than 30 days, reapply a single coat at the single application rate within 7 days of placing the pavement.

At locations where it is necessary to carry traffic across the CTB, place a layer (8 inches or greater, compacted depth) of stable earth (sand-clay) over the CTB.

The Contractor may place portland cement concrete pavement (PCCP) on the CTB after a minimum of 24 hours, provided all traffic and construction equipment is kept off the CTB.

The Contractor assumes the risk of 7-day compressive strength requirements when PCCP is placed early.

To promote cracking through the full depth of the base, score or cut the finished CTB surface to coincide with the pavement joint locations, in a parallel manner and within 1 foot:

- if the 7-day compressive strength exceeds 1600 psi. (Note: This does not apply if the CTB has developed cracks at regular intervals prior to placing the PCCP.)
- if the Contractor opts to place the PCCP over the CTB before the 7-day compressive strength is determined. The Engineer may waive this requirement when the Contractor's control charts for CTB shows a history that the 7-day compressive strength is below 1600 psi.



e. Trimming and Finishing

- Trim and re-compact within 2½ hours of the time the water is added to the aggregate and cementing agent.
- Use automatic equipment.
- Keep the surface moist during all finishing operations.
- Perform operations to produce a smooth, dense surface, free of compaction planes, cracks, ridges or loose material.
- If required, lightly scarify to loosen imprints and recompact surface.



e. Trimming and Finishing

- At the end of each day's operations, construct a straight transverse construction joint by cutting back into the completed work to form a vertical face.
- The Engineer may permit the use of equipment that combines the placing, compacting, and finishing operations based on satisfactory performance of the equipment.



f. Protection and Curing

- Keep the surface of the CTB moist until the curing material is applied.
- Protect the CTB against the loss of moisture for a curing period of 7 days.
- Protect the CTB against freezing during the curing period.
- Apply a wax-based liquid membrane-forming compound for the curing material immediately after completing the trimming and finishing.
- Spec gives details of equipment and application rates to be used.



f. Protection and Curing

- If the wax-based liquid membrane-forming compound has been in place for more than 30 days, reapply within 7 days of placing the pavement using the same application rate.
- At locations where it is necessary to carry traffic across the CTB, place a layer (not less than 8 inches compacted depth) of stable earth (sand-clay) over the CTB.



f. Protection and Curing

- The Contractor will be permitted to place portland cement concrete pavement on the CTB after a minimum of 24 hours, provided all traffic and construction equipment is kept off the CTB.
 - May have to saw or score at pavement joint location.
- If contractor chooses to pave before the 7-day compressive strength is determined, it is at their own risk to do so.



f. Protection and Curing

- To promote cracking through the full depth of CTB, must score or cut the finished CTB surface to coincide with the pavement joint locations, in a parallel manner and within 1 ft.
 - If 7-day strength exceeds 1600 psi. Does not apply if CTB has developed cracks at regular intervals before placing PCCP.
 - If Contractor opts to place the PCCP before the 7-day compressive strength is determined. Engineer may waive if historical records indicate strengths less than 1600 psi.

If the mix is stiff (can be slip-formed), determine the standard density by averaging the 3 most recent field molded densities using plant mixed base material. Compact one standard mold (using plant mixed material with the proper moisture content) for each day's operation as specified in KT-37.

If the mix is fluid (requires forming), determine the Standard Dry Density by averaging the 3 most recent consolidated unit weight test results (KT-20). It will be necessary to convert the unit weight (wet density) into a standard dry density which also requires the percent of moisture (KT-11 (4)) to be known. Use Equation 1 to determine the standard dry density.

$$\text{Equation 1: Standard Dry Density} = \frac{\text{Wet Density}}{(1 + [\% \text{Moisture} / 100])}$$

Determine the density of the CTB within 1 day of the compaction operations. The Engineer may verify the Contractor's density test results by conducting density tests at random. If the comparison is not favorable, the DME will investigate to determine the cause and may suspend production until corrective action is taken.

e. Trimming and Finishing the CTB. Trim and recompact the CTB within 2½ hours of the time the water and cementing agent is added to the aggregate.

Trim and compact the CTB to the grades, lines and typical cross sections shown in the Contract Documents. Dress the edge slopes and joints between sections.

Use automatic grade control equipment to trim the surface of the CTB to line grade and cross section.

Keep the surface of the CTB moist during all finishing operations.

Perform the finishing and compacting operations to produce a smooth, dense surface, free of surface compaction planes, cracks, ridges or loose material.

If required, lightly scarify the surface of the CTB to loosen any imprints left by the trimming and compacting equipment. Recompact the surface of the CTB.

At the end of each day's operations, construct a straight transverse construction joint by cutting back into the completed work to form a vertical face. Place a protective covering of earth on the newly constructed CTB a distance back of the joint for turning of equipment used on the following day's work.

Upon satisfactory performance, the Engineer may approve the use of equipment that combines the placing, compacting and finishing operations.

f. Protection and Curing. Keep the surface of the CTB moist until the curing material is applied. Apply the curing material immediately after completing the trimming and finishing. Protect the CTB against the loss of moisture for a curing period of 7 days (unless the Contractor's mix design test results justify a different curing period). Protect the CTB against freezing during the curing period.

Apply a wax-based liquid membrane-forming compound for the curing material. The minimum application rate for wax-based liquid membrane-forming compound is 0.12 gallons per square yard. Use an enclosed spray system that minimizes wind influence and obtains the proper application rate. Keep all traffic and construction equipment off the CTB. The only exception is the equipment used to apply the curing material. Cover the surface and edges of the CTB with a complete, uniform coverage. Use a hand sprayer in inaccessible areas.

If the wax-based liquid membrane-forming compound will be in place for more than 30 days, reapply a single coat at the single application rate within 7 days of placing the pavement.

At locations where it is necessary to carry traffic across the CTB, place a layer (8 inches or greater, compacted depth) of stable earth (sand-clay) over the CTB.

The Contractor may place portland cement concrete pavement (PCCP) on the CTB after a minimum of 24 hours, provided all traffic and construction equipment is kept off the CTB.

The Contractor assumes the risk of 7-day compressive strength requirements when PCCP is placed early.

To promote cracking through the full depth of the base, score or cut the finished CTB surface to coincide with the pavement joint locations, in a parallel manner and within 1 foot:

- if the 7-day compressive strength exceeds 1600 psi. (Note: This does not apply if the CTB has developed cracks at regular intervals prior to placing the PCCP.)
- if the Contractor opts to place the PCCP over the CTB before the 7-day compressive strength is determined. The Engineer may waive this requirement when the Contractor's control charts for CTB shows a history that the 7-day compressive strength is below 1600 psi.



g. Compressive Strength

- Using random numbers
- Obtain material at the plant
- Make and cure compression test specimens to represent each sublot.
- Determine the 7-day compressive strength of the CTB in accordance with KT-37.
- Maintain records of all sampling and testing.
- Engineer witnesses all compressive strength tests



g. Compressive Strength

- Perform a percent within limits (**PWL**) analysis
 - Lot-by-Lot basis
 - Compressive Strength Values
 - Based on Contractor QC test results
 - Pay Adjustment per Equation 2 (p 300-21)

Equation 2:
$$P = \frac{(PWL_c \times 0.15)}{100} - 0.135$$

- Based on:
 - Compressive Strength values within each lot
 - Lower Specification Lower limit (**LSL**)
 - LSL = 650 psi (p 300-20)



g. Compressive Strength

- F&t Comparison
 - Contractor's QC test results
 - KDOT verification samples (3 to 5)
 - If Contractor's standard deviation (**S**) is < 260 psi, then set **S** to 260 psi.
- F&t Comparison Passes
 - KDOT's verification result falls within the Contractor's mean $\pm 2S$
 - Use Contractor's QC test results for pay adjustment
- F&t Comparison Fails
 - KDOT's verification result does not fall within the Contractor's mean $\pm 2S$
 - Use KDOT's verification test results for pay adjustment



g. Compressive Strength

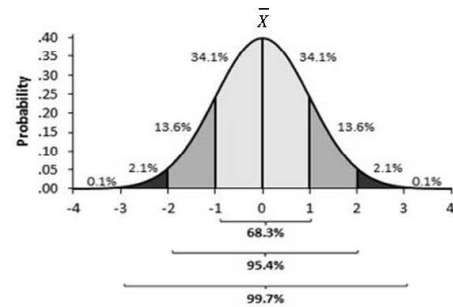

g. Compressive Strength

- A typical lot = normal day's placement
- At beginning of the project
 - Contractor estimates quantity placed in a normal day
 - Engineer must approve
- Divide quantity into 4 equal parts (sublots)
- Determine random sample location for each sublot



g. Compressive Strength

- If total daily quantity deviates from expectations, adjust the number of sublots based on the Table 306-1.

# of Sublots	% of Daily Quantity
4	75 - 115
3	50 - 74
2	25 - 49
1	1 - 24

g. Compressive Strength Determination. Using random numbers, select and obtain sampled material at the plant. Make and cure compression test specimens to represent each subplot. Make and cure compression test specimens, and determine the 7-day compressive strength of the CTB according to Part V. Sulfur cap compression test specimens in accordance with AASHTO T 231. When additional test specimens are taken for early determination of the compressive strength, the specimens are for information only. Perform the 7-day compressive strength testing. Maintain records of all sampling and testing. The Engineer will witness all compressive strength tests and initial the Contractor's documentation.

A percent within limits (*PWL*) analysis shall be made on a lot-by-lot basis and shall be based on Contractor quality control test results on all quality control samples representing the lot of the completed CTB. The *PWL* result shall be determined as specified under Computation of Pay Factor. Compute the pay adjustment as shown in Equation 2. It shall be based on the compressive strength values within each lot and the lower specification limits (*LSL*).

KDOT will use a spreadsheet program to calculate pay adjustments for compressive strength and to compare the Contractor's QC and KDOT's verification test results. If the comparison fails, KDOT's value will be used to calculate the pay adjustment for that lot. The lot comparison is based on KDOT's verification result falling within the Contractor's mean, plus or minus 2 times the Contractor's sample standard deviation. When the Contractor's sample standard deviation is less than 260 psi, then 260 psi shall be used for the sample standard deviation during lot comparison with KDOT's value. When there are 3 or more tests in a lot and when the lot comparison between Contractor and KDOT tests pass, the Contractor's actual standard deviation will be used to calculate the compressive strength pay factor. When requested, KDOT will provide a copy of this program to the Contractor. It is the Contractor's responsibility to obtain the software required to run this program.

Values computed using equations referenced in this specification may vary slightly from the spreadsheet values due to the rounding of numbers. In such cases, the numbers computed by the spreadsheet shall take precedence.

A typical lot is defined as a normal day's placement. At the beginning of the project, estimate the quantity to be placed during a normal day and submit to the Engineer for approval. Once approved, break the quantity into 4 equal parts (each part represents a subplot). Determine a random location for sampling within each subplot. When the total quantity for the day deviates from expectations, adjust the number of sublots based on **TABLE 306-1**.

TABLE 306-1: SUBLOT BREAKDOWN OF A NORMAL DAY'S PRODUCTION	
Number of Sublots	% of Daily Quantity
4	75-115
3	50-74
2	25-49
1	1-24

Adjust the quantity of the last subplot to accommodate any minor changes in production, and adjust the random location for sampling based on the size of the subplot. When there is only 1 test in a lot, the pay factor will be automatically calculated by the KDOT spreadsheet using a sample standard deviation of 260 psi and n of 3. When there are 2 tests in a lot, the pay factor will be calculated by the KDOT spreadsheet using a spreadsheet calculated standard deviation and n of 3. When there are 3 or 4 tests, the lot stands on its own. Regardless of the number of Contractor tests in a lot, the lot comparison between Contractor and KDOT tests will apply. When the quantity exceeds 115% of the normal daily quantity, increase the number of sublots and restrict the 4th subplot to a maximum of 100% of the established normal daily quantity. Each subplot added may have a maximum of 25% of the normal daily quantity.

Compute the sample standard deviation as shown in Section 5.2.1-Statistics, Part V.

Calculate the Compressive Strength Quality Indices (*Q_L*) for each lot as shown in Section 5.2.1-Statistics, Part V. Use the following definitions, and round to the nearest hundredth.

Where: \bar{X} is the average measured compressive strength of all QC samples representing a lot, rounded to 1.0 psi.

LSL is the lower specification limit for compressive strength, defined as 650 psi.

S is the sample standard deviation of the compressive strength of all QC samples representing a lot, rounded to 0.1 psi.



g. Compressive Strength

- Minor changes in production
 - Adjust quantity of last subplot to accommodate
 - Adjust random sampling location based on subplot size
- Small Lots
 - 1 QC Test: $S = 260$ psi and $n = 3$
 - 2 QC Test: $n = 3$
 - Regardless of lot size, F&t comparison is made
- When lot exceeds 115% of normal daily quantity
 - Increase # of sublots
 - Restrict 4th subplot to max of 100% of the established normal daily quantity.
 - Each added subplot has a max of 25% of normal daily quantity (keep additional sublots equal in size)



g. Compressive Strength

For Each Lot

- Compute the sample S
- Calculate Compressive Strength Quality Index (Q_L)
 - Round to the nearest hundredth (0.01)
 - \bar{X} Average of QC Compressive Strengths in lot, round to 1.0 psi
 - LSL : Lower Specification Limit = 650 psi
 - S Sample Standard Deviation for all QC results in the Lot, round to 0.1 psi

$$Q_L = \frac{\bar{X} - LSL}{S}$$



Determination of PWL

- Use Q_L and n to determine the compressive strength percent within limits from the PWL Table in Section 5.2.1 (page 18/26) of Part V.

Table 2 for Estimation of Lot Percent Within Limits
 Variability Unknown Procedure
 Standard Deviation Method

Quality Index Q_L or Q_U	Percent Within Limits for Selected Sample Sizes															
	$N=3$	$N=4$	$N=5$	$N=6$	$N=7$	$N=8$	$N=9$	$N=10$	$N=15$	$N=20$	$N=30$	$N=50$	$N=100$			
0.00	50.00	50.00	50.00	50.00	50.00	50.00	50.00	50.00	50.00	50.00	50.00	50.00	50.00			
0.01	50.28	50.33	50.36	50.37	50.37	50.38	50.38	50.38	50.39	50.39	50.40	50.40	50.40			
0.02	50.55	50.67	50.71	50.73	50.75	50.76	50.76	50.77	50.78	50.79	50.79	50.79	50.80			
0.03	50.83	51.00	51.07	51.10	51.12	51.14	51.15	51.15	51.17	51.18	51.19	51.19	51.19			
0.04	51.10	51.33	51.42	51.47	51.50	51.51	51.53	51.54	51.56	51.57	51.58	51.59	51.59			
0.05	51.38	51.67	51.78	51.84	51.87	51.89	51.91	51.92	51.95	51.96	51.98	51.98	51.99			
0.06	51.65	52.00	52.13	52.20	52.24	52.27	52.29	52.30	52.34	52.36	52.37	52.38	52.39			
0.07	51.93	52.33	52.49	52.57	52.62	52.65	52.67	52.69	52.73	52.75	52.76	52.78	52.78			
0.08	52.21	52.67	52.85	52.94	52.99	53.03	53.05	53.07	53.12	53.14	53.16	53.17	53.18			
0.09	52.49	53.00	53.20	53.30	53.37	53.41	53.43	53.45	53.51	53.53	53.54	53.55	53.56			



Determination of PWL

- If the computed quality index value (Q_L) is a negative value ($\bar{X} < LSL$), then the Engineer will determine if the material in the lot may remain in place.
- If the material is left in place, and there were no individual plugs less than 600 psi, then 50.00 is assigned as the PWL_C value.
- If material is left in place and there are plugs less than 600 psi, then use the calculated PWL_C
- If Q_L is greater than the largest value shown in the table, then $PWL_C = 100.00$



Computation of Pay Factor

Compute the pay factor for compressive strength using Equation 2 and round to nearest thousandth (0.001).

$$P = \frac{(PWL_C * 0.15)}{100} - 0.135$$



Computation of Pay Factor

- Pay Adjustment_(LOT) = $P * SY_{(LOT)} * \$5.00/SY$

For a failing F&t comparison...

- Use KDOT test results to calculate compressive strength pay factor for the lot.
 - X = KDOT's test result for the lot
 - S = 260 psi
 - LSL = 650 psi
 - $n = 4$

Determination of the percent within limits (*PWL*) values. Use the computed *Q* value to determine the compressive strength percent within limits value (*PWLC*) by locating the *QL* values in the left column of the *PWL* Table in Section 5.2.1-Statistics, Part V. Select the appropriate *PWLC* by moving across the selected *QL* to the column representing the number of samples in the lot.

When the computed *QL* is a negative value (\bar{X} lies below the *LSL*), the Engineer will determine if the material in the lot may remain in place. If the material is left in place, and there were no individual plugs found to be less than 600 psi, then 50.00 is assigned as the *PWL* value. For results exceeding these limits and permitted to remain in place, use the calculated *PWL* value.

When the computed *QL* is greater than the largest *QL* value shown in the table, a value of 100.00 is assigned as the *PWL* value for the designated *PWLC*.

Computation of Cement Treated Base Compressive Strength Pay Adjustment. Compute the pay factor for compressive strength using Equation 2 and round to nearest thousandth (0.001). Multiply the pay factor times the square yards, times \$5.00 per square yard to determine the pay adjustment.

Equation 2:
$$P = \frac{(PWL_C \times 0.15)}{100} - 0.135$$

Cement Treated Base Compressive Strength Pay Factor (Failing Comparison Test). When the comparison between Contractor and KDOT tests fails, use KDOT test results to calculate the compressive strength pay factor for the lot. Follow the procedures as stated above to determine the pay factor or disposition of the lot. Use the following values to determine *QL*: \bar{X} of KDOT's test result for the lot, *S* of 260 psi, *LSL* of 650 psi. When selecting the *PWLC* value from the *PWL* in TABLE 2, use *n* of 4.

h. Weather Limitations. Do not place material if the CTB will be exposed to ambient air temperatures below 32°F during the first 7 days of cure. (See **subsections 306.4b., c. and f.**). Remove and replace all CTB that is permitted to freeze within the first 24 hours, whether frozen on the surface or full depth. When materials are exposed to freezing ambient air temperatures after the first 24 hours but before the 7 day cure period is complete, demonstrate that the 7 day design strength has been achieved. Failure to demonstrate the 7 day design strength has been achieved shall require removal and replacement at Contractor's expense.

As directed by the Engineer and at the Contractor's expense, repair or replace cured materials exposed to ambient air temperatures below freezing or repeated freeze/thaw cycles that result in loosening or fluffing of the surface.

A lift of pavement placed prior to exposure to freezing ambient air temperatures constitutes curing of the CTB.

Do not place material on frozen subgrade. Mixing and placing may proceed when the ambient air temperature is 40°F and rising, and discontinue when the ambient air temperatures reaches 45°F and falling.

306.5 MEASUREMENT AND PAYMENT

The Engineer will measure the CTB and quality control testing of CTB by the square yard. Material placed beyond the neat lines indicated in the Contract Documents is not measured for payment unless authorized by the Engineer.

Payment for "Cement Treated Base" and "Quality Control Testing (CTB)" at the contract unit prices is full compensation for the specified work.

No adjustment of the contract unit price for "Quality Control Testing (CTB)" is made for overruns or underruns in the contract quantity.

If the PCCP in the contract is specified as QC/QA, (Quality Control Testing (CTB) is included as a bid item), compressive strength pay adjustments will apply under the bid item "Cement Treated Base Compressive Strength Pay Adjustment", and will be shown as an added item to the contract.

Example Problem #1:

A CTB lot with 4 sublots has the following compressive strength (psi):

10A	700 psi
10B	925 psi
10C	830 psi
10D	1150 psi

$$\bar{X} = 901 \text{ psi}; \quad S = 189.8 \text{ psi}$$

Determine the Quality Index, the percent within limits, and the pay factor for the lot.
Calculate the pay adjustment per square yard for this lot.

Example Problem #2:

A CTB lot with 4 sublots has the following compressive strength (psi):

12A	700 psi
12B	625 psi
12C	610 psi
12D	650 psi

$$\bar{X} = 646 \text{ psi}; \quad S = 39.4 \text{ psi}$$

Determine the Quality Index, the percent within limits, and the pay factor for the lot.
Calculate the pay adjustment per square yard for this lot.



h. Weather Limitations

- Do not place material if the CTB will be exposed to ambient air temperatures below 32°F during the first 7 days of cure.
- Remove and replace all CTB that is permitted to freeze within the first 24 hours, regardless of the depth of the freeze.
- When materials are exposed to freezing temps after 24 hours, but before the 7 day cure is complete, Contractor must demonstrate that 7 day design strength has been achieved, or remove and replace.



h. Weather Limitations

- As directed by the Engineer, repair or replace frozen cured CTB that results in loosening or fluffing of the surface at Contractor expense.
- A lift of pavement placed before exposure to freezing ambient air temperatures constitutes curing of the CTB.
- Do not place CTB on frozen subgrade.
 - May mix and place when ambient air temp is 40°F and rising
 - Discontinue when ambient air temp is 45°F and falling



306.5 Measurement and Payment

- The Engineer will measure the completed and accepted CTB by the square yard (to the nearest 0.1 sq. yd.).
- The Engineer will measure the completed and accepted quality control testing by the square yard (to the nearest 0.1 sq. yd.) of CTB placed and accepted.
- No adjustment of the Contract unit price for "Quality Control Testing (CTB)" is made for overruns or underruns in the Contract quantity.
- When PCCP is QC/QA, then CTB is QC/QA
 - Quality Control Testing (CTB) is a bid item
 - CTB Compressive Strength Pay Adjustment is a bid item

Determination of the percent within limits (*PWL*) values. Use the computed *Q* value to determine the compressive strength percent within limits value (*PWLC*) by locating the *QL* values in the left column of the *PWL* Table in Section 5.2.1-Statistics, Part V. Select the appropriate *PWLC* by moving across the selected *QL* to the column representing the number of samples in the lot.

When the computed *QL* is a negative value (\bar{X} lies below the *LSL*), the Engineer will determine if the material in the lot may remain in place. If the material is left in place, and there were no individual plugs found to be less than 600 psi, then 50.00 is assigned as the *PWL* value. For results exceeding these limits and permitted to remain in place, use the calculated *PWL* value.

When the computed *QL* is greater than the largest *QL* value shown in the table, a value of 100.00 is assigned as the *PWL* value for the designated *PWLC*.

Computation of Cement Treated Base Compressive Strength Pay Adjustment. Compute the pay factor for compressive strength using Equation 2 and round to nearest thousandth (0.001). Multiply the pay factor times the square yards, times \$5.00 per square yard to determine the pay adjustment.

Equation 2:
$$P = \frac{(PWL_C \times 0.15)}{100} - 0.135$$

Cement Treated Base Compressive Strength Pay Factor (Failing Comparison Test). When the comparison between Contractor and KDOT tests fails, use KDOT test results to calculate the compressive strength pay factor for the lot. Follow the procedures as stated above to determine the pay factor or disposition of the lot. Use the following values to determine *QL*: \bar{X} of KDOT's test result for the lot, *S* of 260 psi, *LSL* of 650 psi. When selecting the *PWLC* value from the *PWL* in TABLE 2, use *n* of 4.

h. Weather Limitations. Do not place material if the CTB will be exposed to ambient air temperatures below 32°F during the first 7 days of cure. (See **subsections 306.4b., c. and f.**) Remove and replace all CTB that is permitted to freeze within the first 24 hours, whether frozen on the surface or full depth. When materials are exposed to freezing ambient air temperatures after the first 24 hours but before the 7 day cure period is complete, demonstrate that the 7 day design strength has been achieved. Failure to demonstrate the 7 day design strength has been achieved shall require removal and replacement at Contractor's expense.

As directed by the Engineer and at the Contractor's expense, repair or replace cured materials exposed to ambient air temperatures below freezing or repeated freeze/thaw cycles that result in loosening or fluffing of the surface.

A lift of pavement placed prior to exposure to freezing ambient air temperatures constitutes curing of the CTB.

Do not place material on frozen subgrade. Mixing and placing may proceed when the ambient air temperature is 40°F and rising, and discontinue when the ambient air temperatures reaches 45°F and falling.

306.5 MEASUREMENT AND PAYMENT

The Engineer will measure the CTB and quality control testing of CTB by the square yard. Material placed beyond the neat lines indicated in the Contract Documents is not measured for payment unless authorized by the Engineer.

Payment for "Cement Treated Base" and "Quality Control Testing (CTB)" at the contract unit prices is full compensation for the specified work.

No adjustment of the contract unit price for "Quality Control Testing (CTB)" is made for overruns or underruns in the contract quantity.

If the PCCP in the contract is specified as QC/QA, (Quality Control Testing (CTB) is included as a bid item), compressive strength pay adjustments will apply under the bid item "Cement Treated Base Compressive Strength Pay Adjustment", and will be shown as an added item to the contract.



Section 501 - Portland Cement Concrete Pavement (QC/QA)

- 501.1 Description (500-1)
- 501.2 Contractor QC Requirements (500-1)
- 501.3 Materials (500-4)
- 501.4 Construction Requirements (500-4)
- 501.5 Measurement and Payment (500-16)



Section 501 - Portland Cement Concrete Pavement (QC/QA)

- *Note: PCCP is considered QC/QA when the bid item Quality Control Testing is included in the contract. Note exceptions in subsection 501.5*
- **Description**
 - Construct PCCP on prepared subgrade or base course.
 - Develop and perform quality control testing.
 - Urban PCCP Environment: Projects or section of the project classified as Urban Type are typically:
 - Within city limits
 - Require pieced construction due to business and residential entrances, frequency of side streets, or project phasing.
 - *Meet with Engineer prior to paving to determine if the project or section of project are classified as Urban Type.*



501.1 Description

Bid Items	Units
Concrete Pavement (*Uniform) (AE) (**)	Square Yard
Concrete Pavement (*Variable) (AE) (**)	Square Yard
Quality Control Testing (PCCP)+	Square Yard
Early Strength Concrete Pavement	Square Yard
Concrete Core (Set Price)	Each
*Thickness	
**No entry - PCCP with mesh and dowel assemblies	
"Plain" - PCCP without mesh and dowel assemblies	
"NRDJ" - Non-Reinforced Dowel Jointed PCCP	
+ - Bridge Approach Quantities are not included in this item	



501.1 Description

Examples:

ML: Concrete Pavement (12" Uniform) (AE) (NRDJ)
 SH: Concrete Pavement (12" Variable) (AE) (PLAIN)
 SH: Concrete Pavement (9" Uniform) (AE) (PLAIN)

AE is Air Entrained

Mainline Pavements are Usually Uniform thickness and have doweled joints every 15' (transverse Joint)

Shoulders can be uniform thickness or variable thickness. They are almost always Plain (no dowels or mesh)



Section 501.3 - Materials

Provide Materials that comply with the applicable requirements

Concrete and Grout	Sections 401&403
Aggregates for On Grade Concrete	Section 1116
Concrete Curing Materials	Division 1400
Joint Sealants	Division 1500
Expansion Joint Filler	Division 1500
Preformed Elastomeric Compression Joint	Division 1500
Cold Applied Chemically Cure Joint Sealant	Division 1500
Hot Type Sealing Compound	Division 1500
Backer Rod	Division 1500
Reinforcing Steel	Div 1600/Sec 711
Epoxy Coated Bars for Concrete Reinforcement	Division 1600
Epoxy Resin-Base Bonding System for Concrete	Section 1705
Bond Breakers	Section 1718

PORTLAND CEMENT CONCRETE PAVEMENT (QC/QA)

Note: PCCP is considered QC/QA when the bid item Quality Control Testing is included in the contract. Note the exceptions in subsection 501.5.

501.1 DESCRIPTION

Construct Portland Cement Concrete Pavement (PCCP) on a prepared subgrade or base course. Develop and perform quality control testing.

Urban PCCP Environment: Projects or sections of the project classified as Urban Type are typically:

- within city limits;
- require pieced construction due to:
 - business and residential entrances;
 - frequency of side streets; or
 - project phasing.

Before paving, meet with the Engineer to determine if the project or sections of the project are classified as Urban Type.

BID ITEMS

Concrete Pavement (* Uniform) (AE) (**)
Concrete Pavement (* Variable) (AE) (**)
Early Strength Concrete Pavement (*Uniform) (AE) (**)
Early Strength Concrete Pavement (*Variable) (AE) (**)
Quality Control Testing (PCCP)⁺
Concrete Core (Set Price)

UNITS

Square Yard
Square Yard
Square Yard
Square Yard
Square Yard
Each

* Thickness

** No entry denotes PCCP with mesh and dowel assemblies. "Plain" denotes PCCP without mesh and dowel assemblies. "NRDJ" denotes non-reinforced dowel jointed PCCP. "Br App" denotes bridge approach pavement.

⁺ Br App pavement quantities are not included in this item.

...

501.3 MATERIALS

Provide materials that comply with the applicable requirements.

Concrete and Grout	SECTIONS 401& 403
Aggregates for On Grade Concrete	SECTION 1116
Reinforcing Steel	DIVISION 1600
Epoxy Coated Steel Bars for Concrete Reinforcement	DIVISION 1600
Joint Sealants	DIVISION 1500
Expansion Joint Filler	DIVISION 1500
Concrete Curing Materials	DIVISION 1400
Preformed Elastomeric Compression Joint Seals	DIVISION 1500
Cold Applied Chemically Cured Joint Sealant	DIVISION 1500
Hot Type Joint Sealing Compound	DIVISION 1500
Backer Rod	DIVISION 1500
Epoxy Resin-Base Bonding System for Concrete	SECTION 1705
Bond Breakers	SECTION 1718

SECTION 501.5 MEASUREMENT AND PAYMENT



Measurement and Payment

- a. **Plan Quantity Measurement** (pg. 500-16)
- b. **Measured Quantities** (pg. 500-16)
- c. **Excavation Included in Contract** (pg. 500-16)
- d. **Sawing and Sealing Joints** (pg. 500-16)
- e. **Quality Control Testing** (pg. 500-16)
- f. **Water** (pg. 500-17)
- g. **Pavement Thickness and Compressive Strength Determination** (pg. 500-17)
- h. **Pay Adjustments for Mainline and Other Specified Pavement** (pg. 500-20)
- i. **Pay Adjustments for Pavements Cored for Thickness Only** (pg. 500-21)
- j. **Pay Adjustments for Urban PCCP Environment** (pg. 500-22)
- k. **Computations and Rounding** (pg. 500-22)
- l. **General Payment** (pg. 500-22)



Measurement and Payment

- **Plan Quantity Measurement** (pg. 500-16)
 - Payment based on quantities shown in Contract Documents
 - Either party may request an actual measurement
- **Measured Quantities** (pg. 500-16)
 - The quantity paid for will be the number of SY measured in place as detailed in the specification.
 - Width: Typical X-section and Widening
 - Length: Measured horizontally along centerline
- **Excavation Included in Contract** (pg. 500-16)
 - Additional excavation to obtain the specified elevation will not be measured.



Measurement and Payment

- **Sawing and Sealing Joints** (pg. 500-16)
 - Not measured, all requirements are included in the contract price.
- **Quality Control Testing** (pg. 500-16)
 - Measured by SY of PCCP
 - Cores
 - Measured when results from the core information (required for disputed tests) increases payment to the contractor.
 - All other cores subsidiary to this item.
- **Water** (pg. 500-17)
 - Not measured

Remove and replace pavement panels that contain 2 or more longitudinal cracks.

(4) Repair of Cracks in Shoulder Plain PCCP.

(a) Transverse and Diagonal Cracks.

- When a single transverse crack falls within a panel and is within 3 feet of the transverse contraction joint, fill the contraction joint according to the Contract Documents and rout and seal the crack.
- When 2 or more transverse cracks fall within a panel, remove and replace the panels.

(b) Longitudinal Cracks.

- When a single longitudinal crack falls within a panel, repair pavement by **SECTION 505 - TIE BAR INSERTION-REPAIR**.
- When 2 or more longitudinal cracks fall within a panel, remove and replace the panels.

l. Protection of Pavement from Rain. Before placing PCCP, prepare and submit to the Engineer for approval, a Protection Plan to address the onset of rain during concrete placement. As a minimum, the plan shall include protective covering and side forms available at the project site at all times to protect the surfaces and edges of the newly placed concrete pavement. Polyethylene, burlap or other covering materials may be used. Side forms may be of wood or steel and shall have a depth a minimum of the thickness of the pavement. Specify the location of the storage site in order that a review of the protective materials may be conducted by the Engineer.

Include the type and amount of protective materials as well as the methods proposed to protect the pavement.

When rain appears imminent, stop all paving operations and initiate the Protection Plan. Extend the covering back to the point where the rain will not indent the surface. Exercise care to prevent unnecessary damage to the surface with the covering.

m. Pavement Smoothness. Evaluate pavement smoothness for pay according to **SECTION 503**.

501.5 MEASUREMENT AND PAYMENT

a. Plan Quantity Measurement. The quantities of concrete pavement for which payment will be made are the quantities shown in the Contract Documents for the traveled way lanes and the various paved approaches, exits and interchanges, provided the project is constructed essentially to details shown in the Contract Documents.

When the Contract Documents have been altered, or when a disagreement exists between the Contractor and the Engineer as to the accuracy of the Contract Document quantities in any location or the entire project, either party has the right to request and cause the quantities involved to be measured according to **subsection 501.5b**.

b. Measured Quantities. The quantity to be paid for under this item will be the number of square yards of concrete pavement as measured in-place. The width for measurement will be the width of the pavement shown on the typical cross-section of the Contract Documents, additional widening where added, or as otherwise directed in writing by the Engineer. The length will be measured horizontally along the centerline of each roadway or ramp.

c. Excavation Included in Contract. On projects where the grading and the pavement or base construction is included in the same contract, the Engineer will not measure additional excavation required to obtain the specified subgrade elevation.

d. Sawing and Sealing Joints. The Engineer will not measure this work for separate payment. All costs of complying with the requirements specified herein are included in the contract price for the concrete pavement in which the joints are located.

e. Quality Control Testing. The Engineer will measure the Contractor's quality control testing by the square yard of PCCP placed on the project. The Engineer will measure each concrete core when the results from the core information (required for disputed tests) increases payment to the Contractor. All other cores taken as required by this specification are subsidiary to this item.

Kansas Measurement and Payment

- a. Plan Quantity Measurement (pg. 500-16)
- b. Measured Quantities (pg. 500-16)
- c. Excavation Included in Contract (pg. 500-16)
- d. Sawing and Sealing Joints (pg. 500-16)
- e. Quality Control Testing (pg. 500-16)
- f. Water (pg. 500-17)
- g. **Pavement Thickness and Compressive Strength Determination** (pg. 500-17)
- h. Pay Adjustments for Mainline and Other Specified Pavement (pg. 500-20)
- i. Pay Adjustments for Pavements Cored for Thickness Only (pg. 500-21)
- j. Pay Adjustments for Urban PCCP Environment (pg. 500-22)
- k. Computations and Rounding (pg. 500-22)
- l. General Payment (pg. 500-22)

Kansas (g) Thickness and Strength

(1) General (pg. 500-17)

- Pay adjustments based on cores taken from each lot.
- Make pavement smoothness corrections before making pavement thickness determination.

Construction Type – Pay Adjustment

- Mainline pavement – thickness and compressive strength
- Acceleration/deceleration lane, frontage road, side road and ramp – thickness only
- Gore areas, bridge approach slabs, intersection curb returns, entrances, shoulders, medians, widenings – cores not required

Three Types of Lots

Kansas (g) Thickness and Strength

(1) General (pg. 500-17)

- Where coring is not required...
 - Use string line, survey or other suitable depth measurements to ensure proper thickness.
 - Use concrete mix designs approved for use in mainline pavement.

Bb. of Cementitious per yd ³ of Concrete, minimum	Bb. of Water per Bb. of Cementitious, maximum	Percent of Air by Volume	Volume of Permissible Voids, maximum	Surface Resistivity, minimum	Rapid Chloride Permeability, maximum
850	0.45	See subsection 403.3e.	12.0%	9.0 kΩ-cm	3000 Coulombs

Compared to 517 lb/yd³ for pavement

No additional mix designs are needed...

Kansas (g) Thickness and Strength

(2) Lots and Sublots – Defined (pg. 500-17)

- (a) Pay Adjustments for both thickness and strength (*mainline*)
 - 1 Lot = surface area of mainline pavement placed in a single day
 - 1 lot ≈ 5 sublots of approximately equal surface area

Kansas (g) Thickness and Strength

Non-Urban PCCP (pg. 500-17)

- **High Daily Production Rates** >6000 yd²
 - May divide day's production into 2 equal lots
 - 5 sublots each
 - Decide before cores are taken
- **Low Production Rates** <4000 yd²
 - If <1000 SY Combine with next day's production
 - If completing a mix design, then combine with previous day's production

Daily Production Rate in square yards	Number of Sublots
Under 1000 (Urban)	2
1001 – 2000	3
2001 – 4000	4
4001 or more	5

For non-urban PCCP, combine with next day's production

Kansas (g) Thickness and Strength

Urban PCCP (pg. 500-17)

- **Low Production Rates** <1000 yd²
 - Each day is a Lot
 - Take 2 Cores for Strength and Thickness
 - One in A.M.
 - One in P.M.

f. Water. The Engineer will not measure water used in dust control on haul roads, around plant installations, etc.

g. Pavement Thickness and Compressive Strength Determination.

(1) General. Make the required corrections for pavement smoothness before making the pavement thickness determinations. Determination of pavement thickness and pavement compressive strength for the purpose of establishing pay adjustments will be based on test results from cores taken from each lot of pavement.

- For mainline pavement, pay adjustments will be made for both thickness and compressive strength.
- For acceleration lane, deceleration lane, frontage road, side road and ramp pavement, pay adjustments will be made for thickness, but not compressive strength, unless the Contract Documents specifically require compressive strength pay adjustments.
- For gore areas, bridge approach slabs, intersection curb returns, entrances, shoulders, medians and widenings, pay adjustments will not be made for thickness or compressive strength, and pavement cores will not be required.

Where coring is not required, verify that the thickness of the pavement meets or exceeds the Contract Document requirements by use of stringline, survey or other suitable depth measurement. For pavement types not cored for strength, use only concrete mix designs approved for use in the mainline pavement. The Engineer will observe and document the Contractor’s measurement or other means of ensuring the appropriate thickness of the plastic concrete, and the Engineer will verify that only approved mixes are used. Prior to placing any pavement not specifically defined above, reach an agreement with the Engineer as to the applicability of pay factors.

(2) Lots and Sublots Defined.

(a) For mainline and other pavement subject to coring for pay adjustments for both thickness and strength, a lot is defined as the surface area of mainline lane placed in a single day. Normally, divide a lot representing a day’s production into 5 sublots of approximately equal surface area.

For high daily production rates, rates exceeding 6000 square yards per day, the Contractor may choose to divide the day’s production into 2 approximately equal lots consisting of 5 sublots each. Prior to taking any core samples, notify the Engineer of the decision to divide a day’s production into 2 equal lots. For low daily production rates (and not in an urban PCCP environment), the Contractor may choose to divide the lot into a lesser number of sublots as shown in **TABLE 501-1**. When daily production rates are less than 1000 square yards, and not in an urban PCCP environment, combine the day’s production with the next day’s production to form a lot. When a day’s production involves less than 1000 square yards while completing a particular mix design or project, combine with the previous day’s production and treat as a single lot.

For low daily production rates less than 1000 square yards in an urban PCCP environment, consider each day’s production as a separate lot. KDOT’s representative will core (or have cored) a minimum of two randomly-determined sublots per day; one in the morning and one in the afternoon. Each randomly-determined location will be cored for both strength and thickness, and results inserted into the “Urban PCCP” worksheet for pay adjustment.

TABLE 501-1: PCCP SUBLOT BREAKDOWN	
Daily Production Rate in square yards	Number of Sublots
Under 1000 (Urban)	2
1001 – 2000	3
2001 – 4000	4
4001 or more	5

(b) For pavement that is to be cored for thickness only, group each continuous section of acceleration lane, deceleration lane, side road, frontage road and ramp pavement of equal plan thickness and contract unit price into a lot a maximum of 5000 square yards in area. Divide each lot into a minimum of 3 sublots of approximately equal surface area. Sublots shall be a maximum



(g) Thickness and Strength

(2) Lots and Sublots – Defined (pg. 500-17)

- (b) Pay Adjustments for Thickness only
 - Group each continuous section of equal thickness and bid price, not to exceed 5000 yd²:
 - acceleration lane deceleration lane
 - side road frontage road
 - ramp
 - 1 lot ≈ 3 sublots minimum each with a surface area <1000 yd².
- No Lot size definition for miscellaneous pavements not cored for thickness or strength.



(g) Thickness and Strength

(3) Coring (pg. 500-18)

- Engineer reserves the right to generate random locations (notify before coring)
- (a) Thickness and Strength Pay Adjustment
 - Take 1 core having a minimum diameter of 4"
 - Randomly selected within the subplot
 - Optional additional core (≥2") for purpose of early determination thickness only
 - Select sites according to the approved QCP.
 - Take 1 companion core (≥4") for each lot
 - Repair all core holes.
 - Strength Core a minimum of 21 days after placement
 - In time to determine 28-day compressive strengths



(g) Thickness and Strength

(3) Coring (pg. 500-18)

- Engineer reserves the right to generate random locations (notify before coring)
- (a) Thickness and Strength Pay Adjustment (Cont)
 - Engineer approves coring prior to the 21-day minimum (opening to early traffic)
 - If MRC measures and tests the companion core
 - Deliver to the MRC within 25 days after placement.
 - No initial QC compressive strength data > 28 days of age, unless approved by the Engineer.



(g) Thickness and Strength

(3) Coring (pg. 500-18)

- (b) Thickness Pay Adjustment Only
 - Define the lots prior to placement with the Engineer's approval.
 - After placement, randomly select each subplot location. Take 1 core sample with a min. 2" diameter.
 - Coring may be performed at any time after all of the pavement in the lot has been placed.



(g) Thickness and Strength

(4) Core Handling - Thickness

- Mark each core with the lot/sublot
- Transport thickness samples to Lab, ASAP
 - Average 3 caliper readings, 120° apart (0.01")
- Do not test 2" cores for strength
- Do not measure 4" cores for thickness if a separate 2" core was taken for that purpose.
- Engineer will witness all test results.



(g) Thickness and Strength

(4) Core Handling - Strength

- Moist cure 4" cores per KT-49 until tested
- Square ends and tests entire core thickness
- Compression device must be able to test up to 12" cores
- Any length removed is from the bottom of core
- Measure Length and Diameter to 0.01"
- Determine L/D and round to 0.01"
- L/D values ≠ 2.00 must be corrected

of 1000 square yards in size. Sample each subplot in a manner so that each square yard of pavement has a chance of being randomly selected for coring.

(3) Coring. The Engineer reserves the right to generate the random locations. If KDOT plans to generate the random locations, the Contractor will be notified before taking cores for thickness determination.

(a) For mainline and other pavement subject to coring for pay adjustments for both thickness and strength, take 1 core sample having a minimum diameter of 4 inches from a randomly selected site within each subplot. The Contractor has the option of taking an additional core sample having a minimum diameter of 2 inches from a randomly selected site within each subplot for the purpose of making an early determination of the pavement thickness only. Select sites according to the approved QCP. Additionally, take 1 companion core having a minimum diameter of 4 inches per each lot at a randomly selected site as designated by the Engineer. Repair all core holes in a manner approved by the Engineer. Perform all coring for the purpose of determining strength a minimum of 21 days after the pavement has been placed, and in time to determine 28-day compressive strengths. Coring prior to the 21-day minimum will be permitted with approval of the Engineer, when opening to early traffic is desired. If the companion cores will be measured and tested by the MRC, the Engineer will deliver the companion cores to the MRC within 25 days after the pavement has been placed. No initial QC compressive strength data will be accepted for concrete paving that is more than 28 days of age, unless approved by the Engineer.

(b) For all other PCCP subject to coring for pay adjustment, thickness only, define the lots prior to placement with the Engineer's approval.

After placement, randomly select each subplot location. Take 1 core sample having a minimum diameter of 2 inches. Repair all core holes in a manner approved by the Engineer. Coring may be performed at any time after all pavement in the lot has been placed.

(4) Mark each core with the lot and subplot number from which it was selected. Transport the cores to the laboratory as soon as possible and perform the thickness determination. Take 3 caliper measurements on each core at approximately 120° apart. Record these 3 measurements to the nearest 0.01 inch, and average them to represent the height of that core.

Do not test 2-inch core samples for compressive strength. Do not measure 4-inch cores for pavement thickness determination if a separate 2-inch core sample was taken in a subplot for that purpose.

The measured core height will represent the constructed pavement thickness for each pavement subplot. The Engineer will witness thickness determinations and initial the Contractor's documentation.

Moist cure the 4-inch cores to be tested for compressive strength as required in KT-49, until they are tested. Perform the 28-day compressive strength testing on the entire length of the core after squaring the ends according to KT-49. The compression machine shall be capable of testing cores up to and including 12 inches in length. Remove only the excess length that exceeds compression machine capabilities from the bottom of the cores. Determine length and diameter to the nearest 0.01 inch. Determine the length/diameter ratio (LD), and round the result to the nearest hundredth using the following formula:

$$LD = \text{Length} / \text{Diameter}$$

After performing the strength test, correct the compressive strength using a correction factor determined by using the appropriate formula in **TABLE 501-2**.

TABLE 501-2: COMPRESSIVE STRENGTH CORRECTION FACTOR FORMULAS	
LD	Correction Factor
LD < 2	$\frac{100}{95 + 0.2(1/LD) + 19.5(1/LD)^2}$
LD = 2	1.000
LD > 2	$\frac{100}{110 - 5(LD)}$

Kansas LD Correction Factor

TABLE 501-3: COMPRESSIVE STRENGTH CORRECTION FACTOR

LD	Compressive Strength Correction Factor	LD	Compressive Strength Correction Factor
1.00	0.872	2.60	1.031
1.10	0.898	2.70	1.036
1.20	0.920	2.80	1.042
1.30	0.937	2.90	1.047
1.40	0.952	3.00	1.053
1.50	0.963	3.10	1.058
1.60	0.973	3.20	1.064
1.70	0.982	3.30	1.070
1.80	0.989	3.40	1.075
1.90	0.995	3.50	1.081
2.00	1.000	3.60	1.087
2.10	1.005	3.70	1.093
2.20	1.010	3.80	1.099
2.30	1.015	3.90	1.105
2.40	1.020	4.00	1.111
2.50	1.026		

Kansas LD Correction Factor

- For LD less than 2.00, use the following to determine the correction factor:

$$\frac{100}{95 + 0.2 \left(\frac{1}{LD}\right) + 19.5 \left(\frac{1}{LD}\right)^2}$$
- For LD greater than 2.00, use the following factor:

$$\frac{100}{110 - 5(LD)}$$

Kansas Example Problem #2

- For thickness, measure the core as received.
- Measure the core to the nearest 0.01 in. at 3 places about 120° apart.

Core 1A: 7.05, 7.10, and 7.07 in.

Avg. = _____

Kansas Example Problem #2

- Square ends according to KT-49.
- Measure again to determine LD (length divided by diameter).

Core 1A (finished): 6.70 in. (length) by 4.00 in. (diameter)

LD = $\frac{6.70}{4.00}$ = _____

Kansas Example Problem #2

- LD is less than 2.0, so...

$$\frac{100}{95 + 0.2 \left(\frac{1}{LD}\right) + 19.5 \left(\frac{1}{LD}\right)^2}$$

Kansas Example Problem #2

- Test the core for compressive strength according to KT-49.
- Say core 1A tested at 5124 psi.

Corrected Strength = _____ × _____ = _____

↑
According to KT-49, round to nearest 1 psi.



(4) Comparison Testing

- Companion cores will be measured and tested by KDOT for each lot
 - Variances (spread in data) will be compared (F-test)

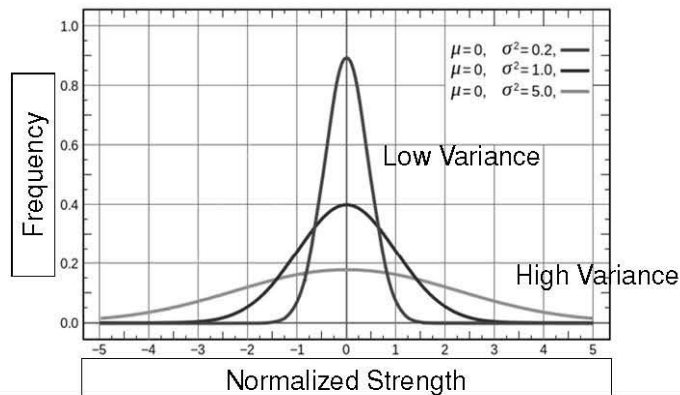

(4) Comparison Testing

- Companion cores will be measured and tested by KDOT for each lot
 - Variances (spread in data) will be compared (F-test)
 - Averages will be compared (T-test)
 - F and T spreadsheet

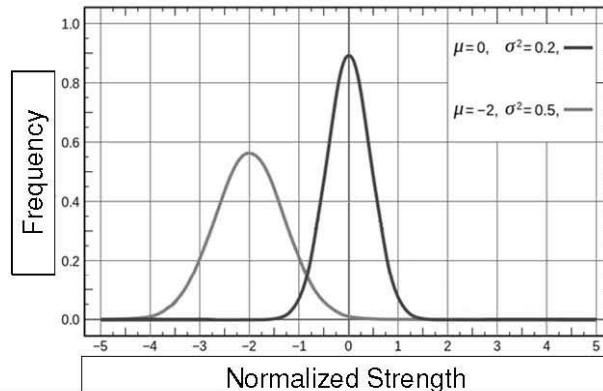

Do these samples come from the same population?



(4) Comparison Testing

- Pavement Acceptance and Pay Adjustments
 - Based on Contractor QC results
 - Provided Statistical Comparison is Favorable
 - Random Samples taken from Lot
 - Based on KDOT Verification results
 - When Statistical Comparison is not Favorable
 - Random Sample from the Lot



(4) Comparison Testing

- Contractor may dispute KDOT's Verification Results.
- If a mutual agreement is not made to use KDOT's results
 - All tests in the Lot are voided
 - New cores for each subplot on a 2 for 1 basis
 - Tested in presence of Engineer within 35 days of placement
 - New Pay Factor determined
 - Loser pays the cost of extra cores



(5) Deficiencies (pg. 500-19)

- Deficiencies in Strength or Thickness
 - Thickness < plan thickness minus 1" or
 - Strength < 2900 psi
 - Take exploratory cores at minimum of 10' intervals
 - On a line passing through deficient core
 - Parallel to the centerline
 - Take cores until
 - Thickness is greater than plan thickness minus 1"
 - Strength is \geq 2900 psi

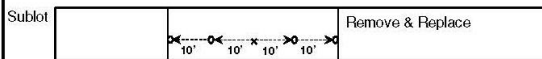

(5) Deficiencies (pg. 500-19/20)

- Determine length of pavement to be removed
- Discard the original core for the subplot
- Randomly select another location
 - Outside of defective area
 - Represents the subplot to compute pay factor
 - Obtain Strength Cores within 35 days of placement
- When Deficient Pavement is Removed
 - Replace with satisfactory quality pavement
 - New Joints no closer than 10' of existing joint
- (6) Thicknesses > 1" thicker than plan thickness, Use Plan Thickness + 1"

The compressive strength correction factor may also be obtained by using **TABLE 501-3**. If a discrepancy should arise due to rounding numbers or the appropriate value is not shown in the table, the value determined by the above formulas shall govern.

TABLE 501-3: COMPRESSIVE STRENGTH CORRECTION FACTOR			
LD	Compressive Strength Correction Factor	LD	Compressive Strength Correction Factor
1.00	0.872	2.60	1.031
1.10	0.898	2.70	1.036
1.20	0.920	2.80	1.042
1.30	0.937	2.90	1.047
1.40	0.952	3.00	1.053
1.50	0.963	3.10	1.058
1.60	0.973	3.20	1.064
1.70	0.982	3.30	1.070
1.80	0.989	3.40	1.075
1.90	0.995	3.50	1.081
2.00	1.000	3.60	1.087
2.10	1.005	3.70	1.093
2.20	1.010	3.80	1.099
2.30	1.015	3.90	1.105
2.40	1.020	4.00	1.111
2.50	1.026		

Correct the compressive strength determined during testing by multiplying that amount by the compressive strength correction factor.

The Engineer will witness all compressive strength tests for each subplot and initial the Contractor’s documentation.

Companion cores will be measured and tested at KDOT’s laboratory to verify the Contractor’s test results. Supply 28-day compressive strength data to KDOT. Acceptance of the pavement and pay adjustments will be on the basis of Contractor quality control test results on random samples taken from a lot, provided the statistical comparison is favorable.

KDOT will routinely compare the variances (F-test) and the means (t-test) of the verification test results with the quality control test results for thickness and compressive strength as appropriate using a KDOT spreadsheet. The F and t-tests, along with the KDOT Spreadsheet used to compare the Contractor’s Quality Control (QC) results and KDOT’s verification (QA) results, are described in Section 5.2.6-Comparison of Quality Control and Verification Tests, Part V. If KDOT verification test results do not show favorable comparison with the Contractor’s quality control test results, KDOT verification test results will be used for material acceptance, material rejection and the determination of any pay adjustment for thickness and compressive strength. Follow the requirements stated in **subsection 501.5h.(6)** for failing t-tests. If the Contractor disputes KDOT’s verification test results, and the Contractor and the Engineer cannot mutually agree on the use of KDOT test results to determine pay adjustments, the test results for the lot in question will be voided. In such case, new cores to represent each subplot will be taken on a 2-for-1 frequency, tested in the presence of the Engineer, and a new pay factor will be calculated using the KDOT spreadsheet. These cores shall be obtained in time to determine the 35-day compressive strengths unless approved by the Engineer. If the new pay factor results in the same or less pay due the Contractor than the voided pay factor, no payment will be made for the additional coring. If the new pay factor results in greater payment to the Contractor, KDOT will pay for each additional core at the contract set unit price.

(5) When the measurement of any core is deficient by more than 1 inch from plan thickness or has a 28-day compressive strength less than 2900 psi, take exploratory cores at a minimum of 10 foot intervals along a line passing through the deficient core and parallel to the centerline of the pavement unit. Continue along this line until an exploratory core taken in each direction is not deficient in length by more than 1 inch, or the compressive strength is a minimum of 2900 psi, depending on which case is being investigated. Exploratory cores will be used only to determine the length of pavement in a unit that is to be removed and replaced as provided below. Discard the original core representing the subplot. Randomly select another core (outside the defective area if left in place) to



h. Pay Adjustments for ML

(1) General

- A single combined pay adjustment, P, will be made for each lot with contractor results (provided F&t passed)

Combined Pay Adjustment = P × # of yd² × Contract unit price



h. Pay Adjustments for ML

(1) General (pg. 500-20)

- Based on 90 percent within limits (PWL)
 - Percentage of samples estimated to be greater than a minimum threshold value.
 - Lower Specification Limit (LSL)
 - Strength = 3900 psi
 - Thickness = Plan thickness – 0.2 in.
 - Based on a normal distribution estimated based on samples.



h. Pay Adjustments for ML

(2 and 3) Quality Indices (pg. 500-20)

- Q_T , normalized thickness

$$Q_T = \frac{\bar{X} - LSL}{S}$$

\bar{X} = Average (nearest 0.1 in.)
 S = sample standard deviation (nearest 0.01 in.)
 LSL = Plan – 0.2 in.
 Q_T rounded to 0.01

- Q_S , normalized strength

$$Q_S = \frac{\bar{X} - LSL}{S}$$

\bar{X} = Average (nearest 1 psi)
 S = sample standard deviation (nearest 0.01 psi)
 LSL = 3900 psi
 Q_S rounded to 0.01

Part V, Section 5.2.1



h. Pay Adjustments for ML

(4) Percent Within Limits (pg. 500-20/21)

- PWL_T and PWL_S
 - Based on Q_S or Q_T and the sample size
 - If either Q_S or Q_T is negative
 - Engineer decides on removal
 - If left in place, the respective PWL = 50%
 - If either Q_S or Q_T is greater than Q in table, use 100% for respective PWL



h. Pay Adjustments for ML

(5) Pay Factor (pg. 500-21)

Equation 1:

$$P = \left(\frac{(PWL_T + PWL_S) * 0.60}{200} \right) - 0.54$$

- If both PWL's = 100.00, P = 0.06
- If one PWL = 100 and the other is 90, P = 0.03
- If both PWL's are 90, P = 0.0 (Full Pay or Bid Price)
- If both PWL's are below 90, P is negative (Deduct)
- If one PWL is 100 and the other is significantly below 90, P can still be negative



h. Pay Adjustments for ML

(6) Failing t-test (pg. 500-21)

- t-test fails, KDOT results will be used.
- Only 1 sample per lot → No S, use the following:
 - Use \bar{X} from KDOT's test for the lot
 - N is equal to the number of contractor sublots
 - S equals 3/8 in. for thickness, and 500 psi for strength
 - LSL is plan thickness – 0.2" for thickness, and 3900 psi for strength

represent the remainder of the subplot and use to compute the pay factor for the lot. All exploratory cores will be obtained in time to determine the compressive strengths within 35 days from the time the pavement was placed, unless approved by the Engineer. Obtain all cores representing the remainder of the subplot and used to compute the pay factor for the lot in time to determine the 35-day compressive strengths, unless approved by the Engineer.

When the Engineer determines that deficient pavement must be removed, the Contractor is required to remove the deficient areas and replace them with pavement of satisfactory quality, strength and thickness. When it is necessary to remove and replace a length of pavement and one end of the deficient pavement is less than 10 feet from an expansion, contraction or construction joint, remove and replace the entire pavement up to the joint. Remove the area so that new joints are a minimum of 10 feet apart. No additional compensation for materials or labor involved in the removal or replacement of the deficient concrete pavement will be made.

(6) For subplot thickness results greater than 1 inch more than design thickness, change the subplot thickness result to 1 inch more than the design thickness. The KDOT spreadsheet will calculate a new lot mean and sample standard deviation based on the corrected value.

h. Pay Adjustments for Mainline and Other Specified Pavement.

(1) General. A single combined pay adjustment for thickness and compressive strength will be made on a lot-by-lot basis and will be based on Contractor quality control test results on all quality control samples representing the lot of the completed pavement provided the statistical check is favorable. Otherwise follow **subsection 501.5g.(4)**. Compute the combined pay factor (P) (positive or negative) as shown in Equation 1.

$$\text{Combined Pay Adjustment} = P \times (\text{the number of square yards included in the lot}) \times (\text{the contract unit price per square yard})$$

The thickness component of the combined pay factor will be based on values determined by using the difference between plan thickness and the measured core sample thickness, and the lower specification limit (LSL). LSL is defined as 0.2 inch less than plan thickness. The compressive strength component of P will be based on the corrected measured compressive strength of core samples taken from the pavement (see **subsection 501.5g.(4)** for LD correction). The pay adjustment amount will be added or subtracted as Concrete Pavement Composite Pay Adjustment on the pay estimate.

Note 1: A lot will normally be comprised of the results of 5 tests performed on a day's placement of a given pavement type. Lot and subplot size is defined in **subsection 501.5g.(2)**.

Note 2: The sample standard deviation (S) will be computed as shown in Section 5.2.1-Statistics, Part V.

(2) Thickness Quality Index (Q_T) Computation. Calculate Q_T for each lot as shown in 5.2.1, Part V, using the following definitions, and round to hundredths.

Where: \bar{X} is the average measured core length of all QC samples representing a lot, rounded to the nearest 0.1 inch.

LSL is the lower specification limit for thickness, and equals plan thickness minus 0.2 inch.

S is the sample standard deviation of the measured core lengths of all QC samples representing a lot, rounded to the nearest hundredth.

(3) Compressive Strength Quality Index (Q_S) Computation. Calculate Q_S for each lot as shown in Section 5.2.1-Statistics, Part V, using the following definitions, and round to the nearest 0.1 inch.

Where: \bar{X} is the average measured compressive strength of all QC core samples representing a lot, rounded to 1 psi.

LSL is the lower specification limit for compressive strength and is defined as 3900 psi.

S is the sample standard deviation of the compressive strength of all QC samples representing a lot, rounded to the hundredth.

(4) Determination of the Percent within Limits Values. First, use the computed Q_T to determine the thickness percent within limits value (PWL_T) by locating Q_T in the left column of the Percent Within Limits (PWL) Table in Section 5.2.1-Statistics, Part V. Select the appropriate (PWL_T) by moving across the selected Q row to the



Example Problem #3

A lot, with 5 sublots, has been cored and tested for both thickness and strength with the following results:

Sublot	Thickness (inches)	Strength (psi)
2A	11.45	5685
2B	10.52	4638
2C	10.40	5349
2D	10.32	6113
2E	10.60	5387
Plan\Specs.	10.5	3900



Example Problem #3

1. Any thickness > 10.5 + 1 in.? _____
 2. Any thickness < 10.5 - 1 in.? _____
 3. Any strength < 2900 psi? _____
- Statistics from the given (corrected) data.

Thickness: $\bar{X} = 10.7$ in., $S = 0.46$ in.
 Strength: $\bar{X} = 5434$ psi, $S = 540.16$ psi

Determine LSL_T for thickness.



Example Problem #3

Determine the quality indices ($N =$):

$$Q_T = \frac{\bar{X} - LSL}{S} =$$

Table 2, Part V:
 $PWL_T =$

$$Q_S = \frac{\bar{X} - LSL}{S} =$$

Table 2, Part V:
 $PWL_S =$



Example Problem #3

Calculate Pay Factor:

$$P = \left(\frac{(PWL_T + PWL_S) * 0.60}{200} \right) - 0.54$$

$$P = \left(\frac{(\quad + \quad) * 0.60}{200} \right) - 0.54 =$$



i. Pay Adjustments – thickness only

(1-3) General (pg. 500-21)

- Handled similarly with only thickness terms Q_T and PWL_T

Thickness Pay Adjustment_{LOT} = $P_T \times \#$ of yd² × Contract unit price

- Thickness Pay Factor (Equation 2)

$$P_T = \left(\frac{(PWL_T) * 0.30}{100} \right) - 0.27$$



i. Pay Adjustments for thickness

(4) Failing t-test (pg. 500-21)

- t-test fails, KDOT results will be used.
- Only 1 sample per lot → No S , use the following:
 - Use \bar{X} from KDOT's test for the lot
 - N is equal to the number of contractor sublots
 - S equals 3/8" for thickness
 - LSL is Plan thickness – 0.2"

column representing the number of samples in the lot. Next, follow the same procedure using the computed Q_S value to select the appropriate compressive strength percent within limits value (PWL_S).

If either computed Q_T or Q_S is a negative value (\bar{X} is less than LSL), the Engineer will determine if the material in the lot may remain in place. If the material is left in place, a value of 50.00 is assigned as PWL_T or PWL_S , respectively. If both Q_T and Q_S are negative, assign a value of 50.00 for each PWL component.

If either Q_T or Q_S is greater than the largest Q shown in the table, a value of 100.00 is assigned as PWL_T or PWL_S , respectively, or for both should Q_T and Q_S both exceed the values shown in the table.

(5) Computation of Combined Pay Factor. Compute P for thickness and compressive strength using Equation 1 and round to nearest hundredth.

$$\text{Equation 1: } P = \left(\frac{(PWL_T + PWL_S) * 0.60}{200} \right) - 0.54$$

(6) Failing t-test. If the t-test fails, KDOT's test result will be used to calculate that particular pay factor for the lot. Follow the procedures given in **subsection 501.5h.(4)** to determine the pay factor or disposition of the lot.

Use the following values to determine Q_T or Q_S :

Where: \bar{X} will be KDOT's test result for the lot.

N is equal to the number of Contractor's sublots.

S will be $\frac{3}{8}$ inch for thickness and 500 psi for strength.

LSL will be as stated in **501.5h.(2)** for determining Q_T , and **501.5h.(3)** for determining Q_S .

i. Pay Adjustments for Pavements Cored for Thickness Only.

(1) General. A single pay adjustment for thickness only will be made on a lot-by-lot basis. It will be based on Contractor quality control test results on all quality control thickness samples representing the lot of the completed pavement provided the statistical check is favorable. Otherwise, follow **subsection 501.5h.(4)**. Compute the thickness pay factor (P_T) (positive or negative) as shown in Equation 2.

Thickness Pay Adjustment = P_T x (the number of square yards included in the lot) x (the contract unit price per square yard)

The thickness component will be based on values determined by using the difference between plan thickness and the measured core sample thickness, and the lower specification limit (LSL). The pay adjustment amount will be added or subtracted as Concrete Pavement Composite Pay Adjustment on the pay estimate.

Note: A lot will normally be comprised of the results of tests performed on all sublots within a given pavement type. Lot and subplot size for pavements cored for thickness only is defined in **subsection 501.5g.(4)**.

(2) Determine PWL_T as shown in **subsection 501.5h.(4)**.

(3) Computation of Thickness Pay Factor. Compute the pay factor for thickness using Equation 2 and round to nearest hundredth.

$$\text{Equation 2: } P_T = \left(\frac{(PWL_T) * 0.30}{100} \right) - 0.27$$

(4) Failing t-test. If the t-test fails, KDOT's test result will be used to calculate that particular pay factor for the lot. Follow the procedures given in **subsection 501.5h.(4)** to determine the pay factor or disposition of the lot.

Use the following values to determine Q_T :

Where: \bar{X} will be KDOT's test result for the lot.

N is equal to the number of Contractor's sublots.

S will be $\frac{3}{8}$ inch for thickness.

LSL will be as stated in **501.5 i.(2)**.



h. Pay Adjustments – Urban PCCP

(1) General (pg. 500-22)

- A single combined pay adjustment P_U will be made for each sublot.
- Based on single randomly selected (KDOT) core for both strength and Δ thickness.
- Remove and Replace if thickness is less than plan thickness – 1.0” or compressive strength is less than 2900 psi
- Maximum pay adjustment is 103%



h. Pay Adjustments – Urban PCCP

(2) Pay Factor (pg. 500-22)

Equation 3: $P_U = (P_{UC} + P_{UT})/2$

$P_{UC} = 0.0001 \times (\text{strength}) + 0.59$ (1 psi)

$P_{UT} = 0.15 \times (\Delta\text{thickness}) + 1.00$ (0.01”)

- Δ thickness is deviation from plan thickness, measure to nearest 0.01 in. (thin is negative)



h. Pay Adjustments – Urban PCCP

(2) Pay Factor (pg. 500-22)

Urban PCCP Pay Adjustment =
 $(P_U - 1) \times (\text{SY in sublot}) \times (\text{contract unit price})$



Measurement and Payment

- a. Plan Quantity Measurement (pg. 500-16)
- b. Measured Quantities (pg. 500-16)
- c. Excavation Included in Contract (pg. 500-16)
- d. Sawing and Sealing Joints (pg. 500-16)
- e. Quality Control Testing (pg. 500-16)
- f. Water (pg. 500-17)
- g. Pavement Thickness and Compressive Strength Determination (pg. 500-17)
- h. Pay Adjustments for Mainline and Other Specified Pavement (pg. 500-20)
- i. Pay Adjustments for Pavements Cored for Thickness Only (pg. 500-21)
- j. Pay Adjustments for Urban PCCP Environment (pg. 500-22)
- k. **Computations and Rounding** (pg. 500-22)
- l. **General Payment** (pg. 500-22)



k. Computations and Rounding

- KDOT will use a MS Excel Spreadsheet
 - Calculate Pay Adjustments
 - Thickness
 - Compressive strength
 - Compare (F&t)
 - Contractor's QC test results
 - KDOT's verification test results
- Contractor may request the Spreadsheet
- Spreadsheet values may vary slightly from hand calculations
 - Due to rounding
 - Spreadsheet takes precedence



l. General Payment

- Payment is full compensation for the work specified
 - "Concrete Pavement"
 - "Early Strength Concrete Pavement"
 - "Quality Control Testing"
- Payment for "Concrete Core (Set Price)"
 - When additional cores needed for dispute
 - Contractor's pay increases from original tests
- Overruns/Underruns for QC testing will not change contract unit price.
- Use the bid item "Concrete Pavement Composite Pay Adjustment" for Pay Adjustments

j. Pay Adjustments for Urban PCCP Environment.

(1) General. A single pay adjustment will be made on a subplot-by-subplot basis. The adjustment will be based on a single randomly-selected (by KDOT) core for both strength and thickness. Compute the pay factor (P_U) (incentive or disincentive) as shown in **Equation 3**.

The thickness component will be based on values determined by using the difference between plan thickness and the measured core sample thickness. When the measured core sample thickness is greater than the plan thickness, the “ Δ thickness” of **Equation 3** is positive. When the core thickness is less than the plan thickness, the “ Δ thickness” is negative. The compressive strength component will be based on values determined by breaking the core. Pay adjustment amount will be added or subtracted on the pay estimate. Remove and replace when values are less than those stipulated in **subsection 501.5g.(5)**. Maximum individual or combined pay adjustment is 103%.

(2) Computation of Urban PCCP Pay Factor. Compute the pay factor for thickness and strength using **Equation 3** and round to nearest hundredth.

Equation 3: $P_U = (P_{UC} + P_{UT})/2$

Where:

$P_{UC} = 0.0001 * (\text{strength}) + 0.59$; where strength is measured to the nearest 1 psi.

$P_{UT} = 0.15 * (\Delta \text{ thickness}) + 1.00$; where Δ thickness is measured to the nearest 0.01 inch from plan thickness.

(3) Computation of Urban PCCP Pay Adjustment. Compute the subplot pay adjustment using **Equation 4**.

Equation 4: Urban PCCP Pay Adjustment = $(P_U - 1) \times$ (the number of square yards included in the subplot) x (the contract unit price per square yard)

This adjustment will be paid for under the bid item Concrete Pavement Composite Pay Adjustment.

k. Computations and Rounding. KDOT will use a MICROSOFT EXCEL spreadsheet program to calculate pay adjustments for thickness and compressive strength and to compare the Contractor’s QC and KDOT’s verification test results. KDOT will provide a copy of this program to the Contractor, when requested. Additional information on the program may be obtained from the Bureau of Construction and Materials. It is the Contractor’s responsibility to obtain the software required to run this program.

Values computed using equations referenced in this specification may vary slightly from the spreadsheet values due to rounding of numbers. In such cases the numbers computed by the spreadsheet take precedence.

I. General Payment. Payment for "Concrete Pavement", "Early Strength Concrete Pavement" and "Quality Control Testing" with pay adjustments as specified above is full compensation for the work specified.

Payment for "Concrete Core (Set Price)" at the contract set unit price will be paid when the results from the core information (required for disputed tests) increases payment to the Contractor.

In the event of overruns or underruns of the Contractor quality control testing, the Engineer will not adjust the contract unit price.

Pay adjustments for thickness-only and pay adjustments for thickness and strength combined will use the bid item "Concrete Pavement Composite Pay Adjustment", and will be shown as an added item to the contract



Example Problem #4

A lot, with 4 sublots, has been cored and tested for thickness only with the following results:

Sublot	Thickness (inches)
6A	10.61
6B	10.80
6C	12.63
6D	12.25
Plan\Specs.	10.5

Thickness: $\bar{X} =$, $S =$ in.



Example Problem #4

1. Determine LSL_T for thickness
2. Determine Quality Index, Q_T
3. Determine PWL_T
4. Determine the pay factor, P_T

$$LSL_T =$$

$$Q_T = \frac{\bar{X} - LSL}{S} = \frac{\quad - \quad}{\quad} =$$

$$PWL_T =$$

$$P_T = \left(\frac{(\quad) * 0.30}{100 - \quad} \right) - 0.27 =$$

SECTION 501 - PORTLAND CEMENT CONCRETE PAVEMENT (QC/QA)

- 501.1 Description (500-1)
- 501.2 Contractor QC Requirements (500-1)
- 501.3 Materials (500-4)
- 501.4 Construction Requirements (500-4)
- 501.5 Measurement and Payment (500-16)

501.4 CONSTRUCTION REQUIREMENTS

- a. Preparation of Subgrade (500-4)
- b. Slip Form Paving (500-5)
- c. Placing Reinforcement (500-6)
- d. Consolidation and Finishing (500-6)
- e. Fixed Form Paving (500-7)
- f. Texturing (500-8)
- g. Joints (500-8)
- h. Hand Finishing (500-12)
- i. Protection and Curing of Concrete (500-12)
- j. Cold Weather Limitations (500-13)
- k. Repair of Defective Slabs (500-13)
- l. Protection of Pavement from Rain (500-16)
- m. Pavement Smoothness (500-16)



Section 501.4 Construction Requirements

a. Preparation of Subgrade

- Complete Ditches and Drains
- Trim base or subgrade
- Maintain base or subgrade to as-constructed condition
- Maintain subgrade to drain at all times
- Protect subgrade from damage
- Do not stockpile material on subgrade



Section 501.4 Construction Requirements

a. Preparation of Subgrade (cont.)

- Do not place material or pavement
 - On Frozen Subgrade
 - On Muddy Subgrade
 - When it's precipitating (rain or snow)
- Lightly spray subgrade or base with water to moisten prior to placing concrete – prevent puddling of water
- Do not place material on unapproved subgrade or base

501.4 CONSTRUCTION REQUIREMENTS

a. Preparation of the Subgrade. Before placing any surfacing material on any section, complete the ditches and drains along that section to effectively drain the highway. Trim the base or subgrade to the line, grade and typical cross-section as shown in the Contract Documents. Maintain the subgrade or base to the as-constructed condition under other bid items, repairing any encountered defects to the specifications of those bid items. Maintain the subgrade surface to readily drain at all times. Protect the subgrade from damage when handling materials, tools and equipment. Do not store or stockpile materials on the subgrade. Do not place material or lay pavement on a frozen or muddy subgrade, or when it is raining or snowing.

Lightly spray the subgrade or base with water to obtain a thoroughly moistened condition when the concrete is deposited on it. Do not puddle water on the grade.

Do not deposit any material until the subgrade or base has been checked and approved by the Engineer.

b. Slip Form Paving. When paving is performed with a slip form paving unit, use equipment as described in **subsection 154.5.**

Pave 24-foot wide mainline pavement in a single operation. Do not exceed 24-foot paving width in a single operation except as follows:

- The Contractor may pave a maximum of 2 lanes plus a 6-foot shoulder (30 feet maximum) in a single operation.
- For pavements of 3 lanes or more, pave a minimum of 2 lanes mainline (with the option of including a single shoulder for a maximum of 30 feet) in a single operation.
- Approval will be based on satisfactory performance of the Contractor's operation.

Place ramps and auxiliary lanes/shoulders as shown in the Contract Documents.

Once the paving operation has started, provide adequate equipment and supply of materials to maintain continuous placement for any given working period. Keep all concrete conveying equipment clean.

Do not apply any tractive forces to the slip form paver, except that which is controlled from the machine.

Trim to grade the subgrade or surface of the base over which the tracks of the paver will travel. Do not disturb this surface with other equipment. If the equipment or method of operation requires the subbase to be wider than shown in the Contract Documents, place additional material to provide an adequate surface for the tracks of the paver. Upon completion of the paving operations, remove or repair any base material damaged by the slip form paver's tracks. All necessary construction and removal of this additional base material is subsidiary to other items of the contract.

Operate the paver continuously, stopping only when absolutely necessary. If the forward motion of the paver is stopped, immediately stop the vibrator and tamping elements.

Deposit the concrete on the grade in successive batches to minimize re-handling. Place concrete over and against any joint assemblies so the joint assembly is retained in its correct position. Spread the concrete using approved mechanical spreaders to prevent segregation and separation of the materials.

After striking the concrete off with the spreader, leave sufficient concrete in place to allow the final shaping by the use of screeds, templates and pans, depending on make, model and type of machines approved for use in the paving train. Adjust the paving units to meet the required final cross-section, minimizing the need to carry back concrete to fill voids or depressions. Adjust each screed or template so a uniform roll of concrete extends the full length of the screed or template and allows just enough concrete to pass under the unit to properly feed the next machine. Do not shove large volumes of concrete with the screed or template. Adjust the screed or template to maintain a uniform cross-section.

Use multiple spreaders for single and multiple lift operations. Place concrete ahead of the initial spreader strikeoff no more than 30 minutes ahead of the final spreader strikeoff.

The use of any paving machine in the paving train is contingent on its ability to finish the pavement satisfactorily to the required grade, section and specified degree of consolidation. The Engineer may at any time require the adjustment, repair or replacement of the machine for unsatisfactory performance.

Correct any edge slump of the pavement in excess of ¼ inch, exclusive of edge rounding, before the concrete hardens. Excessive edge slumping will be sufficient reason to discontinue paving until machinery (or mix) is properly adjusted or removed from the project.

When the machine finishing has been completed, check the surface with a straightedge a minimum of 10 feet in length before texturing. Operate the straightedge parallel to the pavement centerline, starting at the center and



Section 501.4
Construction Requirements

b. Slip Form Paving (Section 154.5)

- 154.5 SLIP FORM PAVING EQUIPMENT
 - In one pass (freshly placed concrete)
 - Spread
 - Consolidate
 - Screed
 - Float finish
 - Automatically controlled
 - From a reference system
 - in regard to line and grade



Section 501.4
Construction Requirements

b. Slip Form Paving (Section 154.5)(cont.)

- 154.5 SLIP FORM PAVING EQUIPMENT
 - Automated electronic vibrator monitoring system on all mainline paving.
 - Not required on shoulders
 - Display frequency for each vibrator
 - Visible to Operator and Inspector
 - Operate continuously while paving
 - Traveling Side Forms
 - Prevent Edge Slump
 - Maximum radius of Top Finishing Edge is ¼"



Section 501.4
Construction Requirements

b. Slip Form Paving (cont.)

- Pave 24-foot wide Mainline in a single operation
- Do not exceed 24 feet width in single operation except:
 - 2 lanes + 6-foot shoulder (30-foot max)
 - When paving 3 lanes or more
 - Minimum of 2 mainline lanes
 - Option of including a single shoulder for 30-foot max
- Approval based on satisfactory performance of Contractor's operation



Section 501.4
Construction Requirements

b. Slip Form Paving (cont'd)

- Operate paver continuously
- When Paver stops moving, Immediately stop vibrator and tamping elements
- Deposit concrete on-grade in successive batches to minimize handling
- Deposit concrete on dowel baskets
- Use mechanical spreaders (segregation)
- Maintain a uniform cross-section
- Correct edge slump > ¼"

154.5 SLIP FORM PAVING EQUIPMENT

Use standard manufacture, slip form paving equipment capable of spreading, consolidating, screeding and float finishing freshly placed concrete in one pass. Use slip form equipment capable of producing a homogeneous pavement to the specified cross-section, profile and density.

Use slip form paving equipment that is automatically controlled (from a reference system) in regard to line and grade.

Use an automated electronic vibrator monitoring system on all mainline paving. (This system is not required on shoulders, if a separate paver is used strictly for shoulders.) Use a system capable of displaying the operating frequency of each individual internal vibrator. Equip the monitoring device with a readout display near the operator's controls visible to the paver operator and the Inspector. Operate the monitoring device continuously while paving, and display all vibrator frequencies with manual or automatic sequencing among all individual vibrators.

Use slip form paving equipment equipped with traveling side forms. The traveling side forms shall trail behind the paver a sufficient distance to prevent edge slump of the concrete pavement. The top finishing edge of the traveling side forms shall have a maximum radius of ¼ inch.

Use all the component parts recommended by the manufacturer of the slip form paving equipment (paving train).

If any unit of the paving train shall operate on adjacent pavement, protect the adjacent pavement.

501.4 CONSTRUCTION REQUIREMENTS

b. Slip Form Paving. When paving is performed with a slip form paving unit, use equipment as described in subsection 154.5.

Pave 24-foot wide mainline pavement in a single operation. Do not exceed 24-foot paving width in a single operation except as follows:

- The Contractor may pave a maximum of 2 lanes plus a 6-foot shoulder (30 feet maximum) in a single operation.
- For pavements of 3 lanes or more, pave a minimum of 2 lanes mainline (with the option of including a single shoulder for a maximum of 30 feet) in a single operation.
- Approval will be based on satisfactory performance of the Contractor's operation.

Place ramps and auxiliary lanes/shoulders as shown in the Contract Documents.

Once the paving operation has started, provide adequate equipment and supply of materials to maintain continuous placement for any given working period. Keep all concrete conveying equipment clean.

Do not apply any tractive forces to the slip form paver, except that which is controlled from the machine.

Trim to grade the subgrade or surface of the base over which the tracks of the paver will travel. Do not disturb this surface with other equipment. If the equipment or method of operation requires the subbase to be wider than shown in the Contract Documents, place additional material to provide an adequate surface for the tracks of the paver. Upon completion of the paving operations, remove or repair any base material damaged by the slip form paver's tracks. All necessary construction and removal of this additional base material is subsidiary to other items of the contract.

Operate the paver continuously, stopping only when absolutely necessary. If the forward motion of the paver is stopped, immediately stop the vibrator and tamping elements.

Deposit the concrete on the grade in successive batches to minimize re-handling. Place concrete over and against any joint assemblies so the joint assembly is retained in its correct position. Spread the concrete using approved mechanical spreaders to prevent segregation and separation of the materials.

After striking the concrete off with the spreader, leave sufficient concrete in place to allow the final shaping by the use of screeds, templates and pans, depending on make, model and type of machines approved for use in the paving train. Adjust the paving units to meet the required final cross-section, minimizing the need to carry back concrete to fill voids or depressions. Adjust each screed or template so a uniform roll of concrete extends the full length of the screed or template and allows just enough concrete to pass under the unit to properly feed the next machine. Do not shove large volumes of concrete with the screed or template. Adjust the screed or template to maintain a uniform cross-section.

Use multiple spreaders for single and multiple lift operations. Place concrete ahead of the initial spreader strikeoff no more than 30 minutes ahead of the final spreader strikeoff.



Section 501.4 Construction Requirements

b. Slip Form Paving (cont'd)

- Grade Control
 - Erected Stringline
 - Tightly Stretched Wire
 - One or Both Sides
 - Usually Supported at 25' to 50' intervals
 - Stringless Paving
 - Horizontal Control – GPS
 - Vertical Control – Total Station (Section 802)



Section 501.4 Construction Requirements

c. Placing Reinforcement

- Use metal bar supports to hold steel down
- Tie Bars
 - Mechanically placed if satisfactory
 - Staked down if not mechanical
- Dowel Bars
 - Mechanical placement not permitted
 - Staked down, usually in baskets
 - Use bond breaker, 15 mils ± 5 mils
- Reinforcing steel free of anything that could impair the bond with concrete

b. Slip Form Paving (Cont)

The use of any paving machine in the paving train is contingent on its ability to finish the pavement satisfactorily to the required grade, section and specified degree of consolidation. The Engineer may at any time require the adjustment, repair or replacement of the machine for unsatisfactory performance.

Correct any edge slump of the pavement in excess of ¼ inch, exclusive of edge rounding, before the concrete hardens. Excessive edge slumping will be sufficient reason to discontinue paving until machinery (or mix) is properly adjusted or removed from the project.

When the machine finishing has been completed, check the surface with a straightedge a minimum of 10 feet in length before texturing. Operate the straightedge parallel to the pavement centerline, starting at the center and progressing outward. Advance in successive stages of less than ½ the length of the straightedge. At the Contractor's option, this requirement may be eliminated when smoothness is to be determined by the profilograph.

Achieve grade control by use of 1 or more of the following grade reference devices. Approval of any of these devices will be based upon satisfactory performance.

Erected Stringline. Use an erected stringline consisting of a tightly stretched wire or string offset from and parallel to the pavement edge on 1 or both sides. Erect the stringline parallel to the established pavement surface grade and support at intervals as necessary to maintain the established grade and alignment.

Stringless Paving. Control line, grade and pavement cross-section as shown in the Contract Documents. Use electronic guidance systems that meet the requirements and tolerances listed in **SECTION 802**. Horizontal control is guided by GPS. Vertical control is guided by Total Stations. GPS will not be allowed for Vertical control.

When paving on a fresh subgrade that has not been trimmed by an automatically controlled machine, use an erected stringline or stringless paving to establish grade. When directed by the Engineer, use an erected stringline or stringless paving to match grade control points such as bridges.

c. Placing Reinforcement. Place pavement reinforcement at the locations shown in the Contract Documents. Use a sufficient number of approved metal, bar supports or pins to hold all dowel bars and tie bars in proper position as required by the Contract Documents. Install tie-bars perpendicular to the concrete face being tied together. Do not use stones, concrete or wood to support the reinforcement.

Joint tie bars may be installed mechanically if approved by the Engineer. The satisfactory placement of the bars depends on the ability of the Contractor's operation to place and maintain the bars in their true position. When satisfactory placement is not obtained by mechanical means, the Engineer may require the tie bars be installed ahead of placing the concrete, and that they be securely held in their exact position by staking and tying.

Do not install dowel bars mechanically. Install the dowel bars ahead of placing the concrete, and hold them securely in their exact position by staking or tying.

Thoroughly coat each dowel with hard grease or other approved bond breaker as shown in the Contract Documents. The bond breaker coating shall not exceed 15 mils ± 5 mils in thickness when averaged over 3 points measured at the ¼ points on the bar at 90° intervals around the bar.

When reinforced concrete pavement is placed in 2 layers, strike off the entire width of the bottom layer to such length and depth that the sheet of fabric or bar mat may be laid full length on the concrete in its final position without further manipulation. Place the reinforcement directly on the concrete, then place the top layer of concrete, strike it off and screed it. Remove any portion of the bottom layer of concrete that has been placed more than 30 minutes, and replace it with fresh mixed concrete at the Contractor's expense. When reinforced concrete is placed in 1 layer, the reinforcement may be positioned in advance of the concrete placement or it may be placed in the plastic concrete after initial spreading, by mechanical or vibratory means.

Place the wire mesh reinforcement in the pavement at the locations shown in the Contract Documents. When 2 layers of wire mesh reinforcement are required, support the bottom layer in the required position with bar chairs. Use separators for the top layer if the strike-off can not be used properly for the operation. Lap the reinforcement as shown in the Contract Documents. Laps parallel to the centerline of the pavement are prohibited except for unusual width of pavement lanes or for irregular areas. If the Contract Documents do not show dimensions for laps, the minimum lap either perpendicular or parallel to the centerline of the pavement is 6 inches. Fasten or tie adjacent wire mesh sheets together to hold all parts of the wire mesh sheets in the same plane.

If a "wire pattern" appears on the surface of the fresh pavement, immediately modify placement procedures to eliminate the problem.

Use reinforcing steel free from detrimental materials that could impair the bond between the steel and concrete.



Section 501.4
Construction Requirements

d. Consolidating and Finishing

- Hand spread with shovels, not rakes
- Only Clean boots on PCCP
- Do not apply moisture to PCCP surface
 - Engineer approves use to lubricate float
 - If you must, use a fog or mist
- Consolidate concrete without voids
 - Use Vibrators
 - Full width, uniformly
 - Density is 98% of consolidated unit weight



Section 501.4
Construction Requirements

d. Consolidating and Finishing (cont)

- Vibrators (501.4e and 154.2e)
 - Surface Type (min. freq. 3500 cycles/min)
 - Pan
 - Screed
 - Immersion Type
 - Tube (min. freq. 5000 cycles/min)
 - Spud (min. freq. 8000 cycles/min)
- Attach to
 - Spreader
 - Paver
 - Finishing Machine
 - Separate Carriage



Section 501.4
Construction Requirements

d. Consolidating and Finishing (cont)

- Vibrators
 - Check frequencies every 4 hours (ML)
 - If not working, check manually
 - If still not working, remove immediately
 - Document vibrator checks
- Use electronic monitoring system
 - If fails, check manually
 - Correct problem within 3 paving days



Section 501.4
Construction Requirements

d. Consolidating and Finishing (cont)

- Density checked with Nuclear Gauge
- KT-38 Density of Freshly Mixed Concrete in Pavement by Nuclear Method
 - Movable Bridge
 - Transverse profile
 - Check over vibrators and between vibrators
 - Run at start-up
 - Run when change is made that affects consolidation
 - In-Place Density
 - Every 1/2 day
 - In vibrator path and between vibrators

d. Consolidation and Finishing. Perform hand spreading with shovels, not rakes. Do not allow workers to walk in the fresh concrete with boots or shoes coated with earth or foreign substance.

Do not apply moisture to the surface of the concrete pavement unless the Engineer approves the use of additional water on the fresh concrete surface to lubricate the float of the longitudinal finisher. If unusual weather conditions require the addition of superficial water to the concrete surface, apply it only in the form of a fine, fog mist.

Uniformly consolidate the concrete without voids, and finish to the cross-section and elevation shown in the Contract Documents.

Use vibrators or other approved equipment to consolidate each layer of concrete, when placed in more than 1 lift, or full depth if placed in 1 lift. Uniformly vibrate the concrete across the full width and depth of the pavement so that the density of pavement concrete is a minimum of 98% of the consolidated unit weight. The 98% density

requirement may be eliminated on miscellaneous areas such as entrance pavement, median pavement and gore areas.

Vibrators, either of the surface type (pan or screed) or the immersion type (tube or spud) may be attached to the spreader, paver or finishing machine, or may be mounted on a separate carriage. Only operate the vibrators when the machine they are mounted on is moving forward. Do not operate hand vibrators more than 15 seconds, or less than 5 seconds in any one location unless approved otherwise by the Engineer. Place vibrators in and withdraw from concrete vertically in a slow deliberate manner.

On mainline paving, every 4 hours, check the electronic monitoring system vibrator frequencies with the vibrator under load to comply with the frequencies shown in **subsection 154.2e**.

If the system indicates a vibrator is not working properly, manually check the vibrators, immediately. If a vibrator is not functioning properly, immediately replace.

If the electronic monitoring system fails to operate properly, manually check the vibrators, immediately. If the vibrators are functioning properly, paving may continue but make all efforts to correct the problem within 3 paving days. The Engineer may allow additional time if circumstances are beyond the Contractor's control. Perform the vibrator checks manually until the system is fixed.

Document the checks, and give the data to the Inspector, daily. Email a recap of the data to the Engineer, weekly.

Maintain a uniform, continuous roll of concrete over the vibrators ahead of the strike-off. The height of the roll shall be approximately the same height as the thickness of the pavement being vibrated.

In order to obtain concrete consolidation in the vicinity of joint assemblies, the Engineer may require that these areas be hand vibrated with an immersion spud vibrator.

In the event the specified density is not attained, cease paving operations and make necessary adjustments to produce concrete to conform to the density requirements.

Use an approved nuclear density measuring device to monitor in-place density. Provide a moveable bridge and move it to test locations as required to allow the Inspector to work over the fresh concrete.

On projects or areas within projects where the use of conventional equipment is impracticable, other consolidation and finishing equipment may be used with approval of the Engineer.

154.1 VIBRATORS

a. General. Provide the proper testing equipment to determine the frequency of the impulses of the vibrators. See **subsection 154.5** for vibrator monitoring systems used in slip form paving.

e. Vibrators for Rigid Pavement. Use either internal type (spud or tube) vibrators or surface type (pan or screed) vibrators. Use vibrators mounted on the concrete spreader, the finishing machine or a separate carriage. Use vibrators capable of vibrating the full depth of the rigid pavement without coming in contact with the joint, load transfer device, subgrade or forms. Vibrators should operate only when the machine the vibrators are attached to is moving.

Additional requirements for vibrators for rigid pavement:

- The frequency of vibration of surface, pan or screed vibrators shall be a minimum of 3,500 cycles per minute;
- The frequency of vibration of immersion tube vibrators attached to the paving machine shall be a minimum of 5,000 cycles per minute; and
- The frequency of vibration of immersion spud vibrators (both hand operated and gang mounted) shall be a minimum of 8,000 cycles per minute.



Section 501.4
Construction Requirements

e. Fixed Form Paving

- Contractor's Option to use
 - (1) Forms
 - Metal (min 10 feet lengths)
 - Depth equal to prescribed edge thickness
 - No horizontal joint
 - Able to support paving equipment
 - Withstand impact and vibration
 - See Spec for Curved Sections
 - (2) Base Support
 - Compact foundation
 - True to grade
 - Whole length in contact with grade



Section 501.4
Construction Requirements

e. Fixed Form Paving (cont.)

- (3) Form Setting
 - Set in advance to check line and grade
 - Mechanically tamp grade and inside and outside edges of forms
 - Stake with 3 pins per 10' length
 - Pin at each side of each joint
 - Clean and oil forms before placement
- (4) Grade and Alignment - Check
- (5) Reinforcement, Consolidating and Finishing Concrete per 501.4c. and d.
- (6) Removing Forms after 12+ hours



Section 501.4
Construction Requirements

f. Texturing (Equipment: Sect. 154.7)

- Burlap drag
 - When excess moisture has disappeared
 - Plastic concrete (granular surface)
- Longitudinal Tining (154.7c.)
 - Metal Comb
 - Spaced at $\frac{3}{4}$ " centers
 - $\sim 3/16$ " wide
 - $\frac{1}{8}$ " to $\frac{1}{4}$ " deep
- Finish Exposed Edges
 - Exposed edges - $\frac{1}{4}$ " radius with edger
 - Interior longitudinal joints - $\frac{1}{8}$ " radius

e. Fixed Form Paving. At the Contractor's option, the fixed form paving method may be used.

(1) Forms. Use straight, metal forms having adequate strength to support the equipment. Each section shall be a minimum of 10 feet in length. Use forms with a depth equal to the prescribed edge thickness of the concrete, a base width at least equal to the depth of the forms and without a horizontal joint. Use flexible or curved forms of proper radius for curves of 150-foot radius or less, except approved straight forms of 5-foot lengths may be used for curves of a radius from 75 to 150 feet. Flexible or curved forms must be approved by the Engineer. The Engineer may approve the use of wood forms in areas requiring hand finishing. Secure the forms in place to withstand the impact and vibration of the consolidating and finishing equipment without visible spring or settlement. Extend flange braces outward on the base a minimum of $\frac{2}{3}$ the height of the form. Remove forms with battered top surfaces or bent, twisted or broken forms. Do not use repaired forms until they have been inspected and approved by the Engineer. Do not use buildup forms, except where the total area of pavement of any specified thickness on the project is less than 2,000 square yards. Do not vary the top face of the form from a true plane more than $\frac{1}{8}$ inch in 10 feet, and do not vary the vertical face of the form by more than $\frac{1}{4}$ inch. The forms shall contain provisions for locking the ends of abutting form sections together tightly, and for secure setting.

(2) Base Support. Provide a foundation under the forms that is compact and true to the specified grade so that the whole length of the form will be set firmly in contact with the grade.

(3) Form Setting. Set forms sufficiently in advance of the point where concrete is being placed so that line and grade may be checked. After the forms have been correctly set, thoroughly tamp the grade mechanically at both the inside and outside edges of the base of the forms. Stake forms into place with a minimum of 3 pins for each 10 foot section. Place a pin at each side of every joint. Tightly lock form sections, free from play or movement in any direction. Do not deviate the form from true line by more than $\frac{1}{4}$ inch at any point. No excessive settlement or springing of forms under the finishing machine is permitted. Clean and oil forms before the placing of concrete.

(4) Grade and Alignment. Check the alignment and grade elevations of the forms immediately before placing the concrete and make any necessary corrections. When any form has been disturbed or any grade has become unstable, reset and recheck the form.

(5) Placing Reinforcement and Consolidating and Finishing Concrete. Meet the requirements in **subsections 501.4c. and d.**

(6) Removing Forms. Unless otherwise provided, do not remove forms from freshly placed concrete until it has set for a minimum of 12 hours, except auxiliary forms used temporarily in widened areas. Remove forms carefully to avoid damage to the pavement.

f. Texturing. Use texturing equipment and devices as described in **subsection 154.7.**

Use a burlap drag as soon as all excess moisture has disappeared and while the concrete is still plastic enough to make a granular surface possible.

Following the dragging operation, use a mechanical device to make a final finish or texture by giving the surface of the plastic pavement a longitudinal tining, unless shown otherwise in the Contract Documents. Perform the operation at such time to minimize displacement of larger aggregate particles and before the surface permanently sets.

Small or irregular areas may be tined by hand methods.

On projects of less than 5,000 square yards, or projects with longitudinal tining, the tining and curing devices may be mounted on the same carriage when approved by the Engineer. Operations of this type will be based on satisfactory performance.

Before final texturing, finish the exposed edge of the pavement to a radius of $\frac{1}{4}$ inch with an edger. Edge the interior longitudinal joints on multiple-lane pavement to a radius of $\frac{1}{8}$ inch. Eliminate any tool marks appearing on the slab adjacent to the joints or edge of the slab. Do not disturb the rounding of the corner of the slab.

154.2 CONCRETE PAVEMENT TEXTURING EQUIPMENT

a. Longitudinal Grooving Equipment. Use standard manufacture, longitudinal grooving equipment capable of covering the width of the pavement in a single pass. Use longitudinal grooving equipment with a metal comb that is capable of producing a uniform pattern of longitudinal grooves approximately $\frac{3}{16}$ inch wide, spaced at $\frac{3}{4}$ inch centers and $\frac{1}{8}$ to $\frac{1}{4}$ inch deep.

The Engineer may accept longitudinal grooving equipment with a fluted float (instead of a metal comb) provided the fluted float produces longitudinal grooves similar in dimension to the requirements of the metal comb.

Small or irregular areas may be grooved by hand methods.



Section 501.4
Construction Requirements

h. Hand Finishing (minimize)

- Paving Train Breakdown – Finish concrete in place
- Too narrow or too short for full paving spread
- Irregular shaped areas
- Special Approach section to bridges
- Widened portions
- Impossible to pave with power equipment
- Longitudinal Tining (154.7c.)
- Vibrate, consolidate, screed and strike-off
- Burlap drag and texture/tine



Section 501.4
Construction Requirements

i. Protection and Curing of Concrete

- Failure to cure properly – Suspension
- Type 1 Materials:
 - Burlap
 - Concrete Curing Blankets
 - White Polyethylene Sheeting
 - Reinforced White Polyethylene Sheeting
- Type 2 Materials:
 - White Liquid Membrane Forming Compound



Section 501.4
Construction Requirements

i. Protection and Curing of Concrete (cont.)

- Type 1 Materials (keep serviceable):
 - Immediately after Finishing
 - Don't mar the Surface
 - Prevent undue moisture loss
 - Burlap dampen before placement-keep damp
 - Burlap-polyethylene blankets-damp side down
 - Weight blankets down
 - 18" lap
 - Extend curing medium to cover edges
 - In place for minimum of 4 days



Section 501.4
Construction Requirements

i. Protection & Curing of Concrete (cont.)

- Type 2 Materials (Wax Based):
 - Immediately after surface free water is gone
 - Uniform and Complete application
 - Rate of 1 gallon per 150 square feet
 - Protect for minimum of 4 days
 - Minimal foot traffic permitted on dried surface
 - Repair damaged areas
 - Coat edges and sides – hand spraying allowed
 - Repair areas damaged by joint sawing

h. Hand Finishing. Hold hand finishing methods to a minimum. Generally, hand methods of placement and finishing will be permitted as follows:

- For pavement when a breakdown of some portion of the paving train occurs, making the hand finishing of that portion of the concrete already in place necessary.
- For pavement lanes that may be too narrow or a length too short to accommodate a full paving spread.
- For all irregular shaped areas.
- For special approach sections to bridges, widened portions at bridges, intersections and sections widened beyond traffic lanes.
- When the dimensions of the work make the use of a complete power operated paving impossible, or impracticable.

For uniform width areas or transition width areas using false forms, finish handwork with a mechanical finishing machine or approved vibrating screed, whenever possible.

Use spud hand vibrators on any area considered impracticable to vibrate with a vibrating screed. Approved metal or wood floats may be used if needed to help close an open or porous surface condition.

Continue the operation of consolidation and screeding or striking off the concrete until the concrete is uniformly consolidated and the surface is true to line, grade and cross-section.

After the pavement has been properly struck off, straightedge the pavement for trueness and finish it. Use a burlap drag to remove surface straightedge marks. The burlap drag may be pulled by hand, but the results shall be similar to that on the mainline pavement.

Manual methods may be used for texturing hand finished pavement areas. Where applicable, the tined texture applies. Use a metal comb with dimensions and spacing shown in **subsection 154.7c**. Obtain a finished textured surface similar to that produced mechanically.

On miscellaneous areas such as entrance pavement, median pavement and gore areas, texturing with the metal comb may be eliminated. Final finish may be attained by the use of a drag that consists of a seamless strip of damp burlap, cotton fabric or other suitable material capable of producing a uniform surface of gritty texture.

i. Protection and Curing of Concrete. Cure the pavement by using burlap, liquid membrane-forming compounds, white polyethylene sheeting, concrete curing blankets or reinforced white polyethylene sheeting. Failure to provide proper curing is cause for immediate suspension of the concreting operations.

(1) Burlap, Concrete Curing Blankets, White Polyethylene Sheeting and Reinforced White Polyethylene Sheeting. Place the curing material on the pavement immediately after the pavement has been finished, and the concrete has hardened sufficiently to avoid harmful marring of the surface, yet early enough to prevent undue loss of moisture from the concrete. If the pavement becomes dry before the curing material is placed, moisten the concrete with a fine spray of water. Dampen burlap and place on the surface. Place burlap-polyethylene blankets with the dampened burlap side down. Keep burlap damp throughout the entire curing period.

Lap adjacent units of curing materials approximately 18 inches. Upon removal of the forms, extend the material to completely cover the full depth of the exposed pavement.

Weigh the curing material down using continuous windrows of earth placed along the sides and edges of the pavement and transversely across the pavement on the laps to cause the material to remain in contact with the covered surface throughout the curing period. Other methods may be used with approval of the Engineer.

Walking on the pavement surface to place the curing material is prohibited. Walking on the curing material is prohibited until the pavement has cured sufficiently to prevent damage to the surface.

Leave the curing material in place for a minimum of 4 days, unless otherwise directed by the Engineer. Immediately repair any tears or holes appearing in the material during the curing period, or replace it with material in good condition.

The material may be reused, provided it is kept serviceable by proper repairs, and if in the judgment of Engineer it will provide water retention during the curing period.

(2) Type 2 White Liquid Membrane-Forming Compound. After finishing operations have been completed and immediately after the free water has left the surface, completely coat and seal the surface of the slab with a uniform layer of compound. Apply the compound in 1 application at a minimum rate of 1 gallon per 150 square feet of surface. Thoroughly mix the compound at all times during usage. Do not dilute the compound. Daily provide the Inspector documentation of the quantity of curing compound used.

Protect the treated surface from injury a minimum of 4 days, unless otherwise directed by the Engineer. If the newly coated film is damaged in any way, apply a new coat of material to the affected areas equal in coverage to that specified for the original coat. A minimum of foot traffic will be permitted on the dried film as necessary to



Section 501.4 Construction Requirements

i. Protection and Curing of Concrete (cont.)

(3) Opening to traffic

- No motorized traffic until:
- (a) Construction Traffic only:
 - Flexural strength \geq 450 psi
 - 10 day curing period
 - If flexural strength \leq 450 psi
 - Strength gain curve (45°F) to justify $<$ 10 days of cure.
 - Provide protection to keep foreign material out of unsealed joints
- (b) All Traffic:
 - Meet 501.41(3)(a) above
 - Seal joints per 501.5g(9)



Section 501.4 Construction Requirements

i. Protection and Curing of Concrete (cont.)

(4) Cold Weather Curing

- Surface temperature \geq 40°F (4 days)
- Precautions if air temp will drop below 35°F
- Use blanketing material; straw, hay, burlap
- May need a moisture barrier if pavement $<$ 4 days old
- Engineer decides if pavement is damaged by cold weather and needs to be removed, disposed of, and replaced

i. Protection and Curing of Concrete. (cont)

properly carry on the work, provided any damage to the film is immediately repaired by application of an additional coat of compound.

Immediately after the forms are removed (fixed form and slip form), coat the entire area of the sides of the slab with compound at the rate specified for the pavement surface, regardless of whether or not further concrete placement will be made against the pavement edge. Approved hand spray equipment will be permitted only for the application of compound on the sides of the slab, for repairing damaged areas and for hand finished areas. Repair any damaged areas caused by joint sawing.

(3) Opening to Traffic. No motorized traffic is allowed on the pavement until all of the following conditions are met.

(a) Construction Traffic Only.

- The flexural strength of the pavement shall meet or exceed 450 psi. Determine the flexural strength of the pavement by testing flexural strength specimens utilizing the third point loading method, or by use of a calibrated maturity meter.
- If flexural strength does not meet or exceed 450 psi, observe a 10 day curing period before allowing motorized traffic on the pavement. Provide a strength gain curve of concrete cured at 45°F to justify a curing period of less than 10 days.
- Provide protection to keep foreign material out of the unsealed joints by an approved method.

(b) All Traffic. In addition to **subsection 501.4i.(3)(a)**, seal the joints according to **subsection 501.4g.(9)**.

The Contractor may, at own expense, increase the cement content from the minimum shown in **SECTION 403** to accelerate the strength gain of the PCCP.

(4) Cold Weather Curing. Maintain the concrete pavement at a minimum temperature of 40°F, as measured along the surface of the concrete, for a minimum of 4 days after placing. When the ambient air temperature is expected to drop below 35°F anytime during the curing period, take precautions to maintain the concrete temperature. Keep a sufficient supply of approved moisture barrier material, other than liquid curing compound, and suitable blanketing material, such as straw, hay and burlap close by. Be prepared to cover the pavement with a moisture barrier and protect all pavement less than 4 days old with blanketing material. Remove, dispose of and replace concrete damaged by cold weather, as determined by the Engineer.

(5) Early Strength Concrete Curing. The curing period shall conform to the requirements specified for regular concrete pavement in **subsection 501.4.i**. Construct joints according to the manufacturer's recommendations for early strength concrete pavement.

SECTION 501.4G CONSTRUCTION REQUIREMENTS – JOINTS



501.4 CONSTRUCTION REQUIREMENTS

- a. Preparation of Subgrade (500-4)
- b. Slip Form Paving (500-5)
- c. Placing Reinforcement (500-6)
- d. Consolidation and Finishing (500-6)
- e. Fixed Form Paving (500-7)
- f. Texturing (500-8)
- g. Joints (500-8)
- h. Hand Finishing (500-12)
- i. Protection and Curing of Concrete (500-12)
- j. Cold Weather Limitations (500-13)
- k. Repair of Defective Slabs (500-13)
- l. Protection of Pavement from Rain (500-16)
- m. Pavement Smoothness (500-16)



Concrete Joints

- 1. **General** (500-8)
- 2. **Pressure Relief Joints** (500-8)
- 3. **Contraction Joints** (500-9)
- 4. **Longitudinal Joints** (500-9)
- 5. **Construction Joints** (500-9)
- 6. **Special Joint Construction**
- 7. **Joint Construction** (500-9)
- 8. **Cleaning Joints** (500-9)
- 9. **Sealing Joints** (500-10)
- 10. **Sawed (Non-Sealed) Joints** (500-11)



Types of Joints

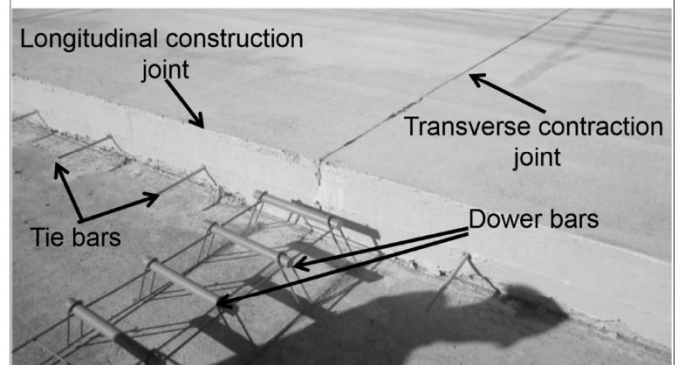

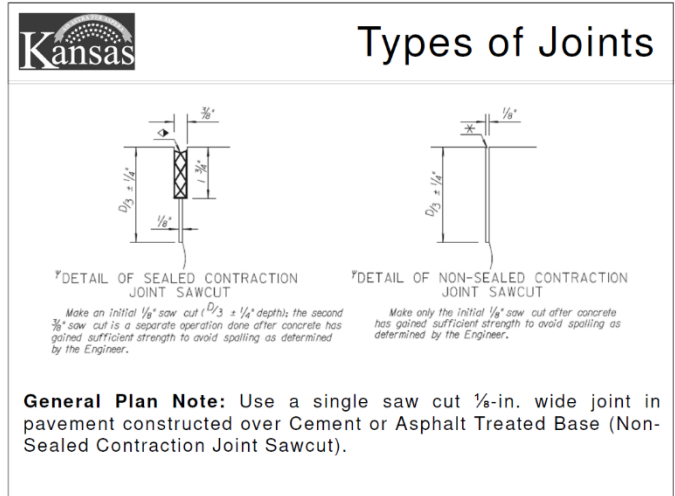
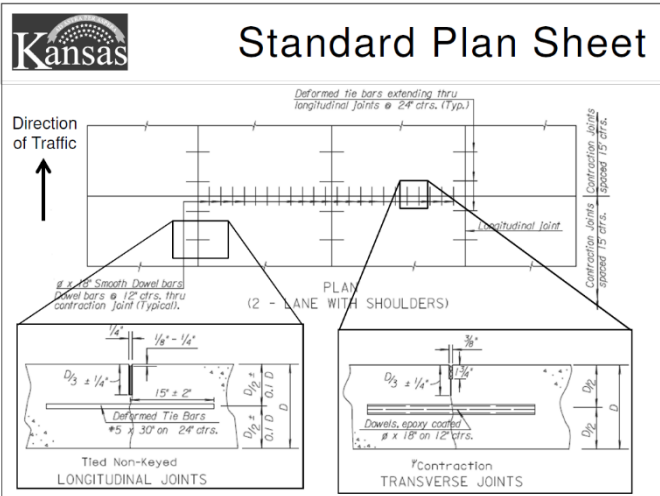

- ### (1) General
- General Considerations**
- Construct according to contract documents – cause of suspension
 - Goal** – Create a plane of weakness to control location of crack.
 - 1/8-in. wide full-depth cut (to $D/3 \pm 1/4$ in.)
 - Initial cut followed by a second cut to create reservoir
 - Initial cut can be in the plastic concrete or with an early entry saw

Typical Cracking

- Saw timing is key
 - Too early – raveling
 - Too late - cracking

IMCP Manual, CP Tech Center

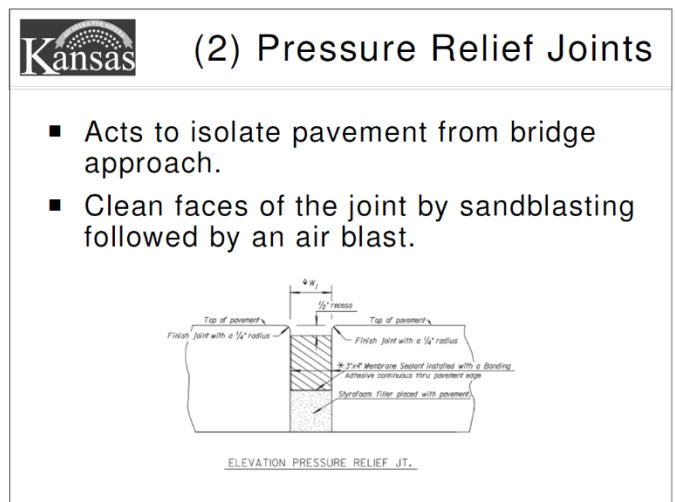
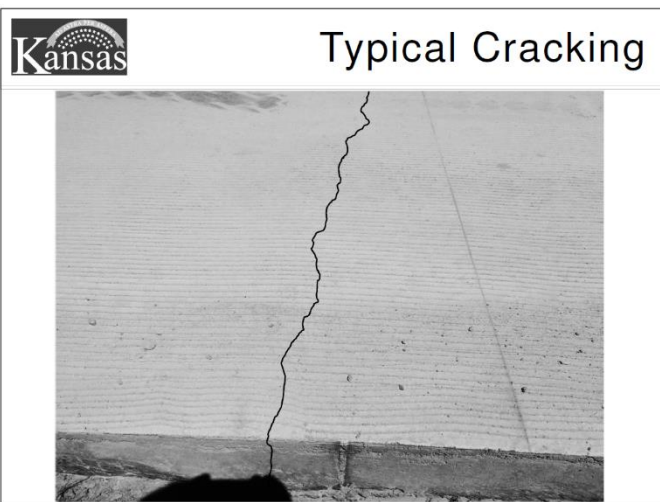

(6) Removing Forms. Unless otherwise provided, do not remove forms from freshly placed concrete until it has set for a minimum of 12 hours, except auxiliary forms used temporarily in widened areas. Remove forms carefully to avoid damage to the pavement.

f. Texturing. Use texturing equipment and devices as described in **subsection 154.7.**

Use a burlap drag as soon as all excess moisture has disappeared and while the concrete is still plastic enough to make a granular surface possible.

Following the dragging operation, use a mechanical device to make a final finish or texture by giving the surface of the plastic pavement a longitudinal tining, unless shown otherwise in the Contract Documents. Perform the operation at such time to minimize displacement of larger aggregate particles and before the surface permanently sets.

Small or irregular areas may be tined by hand methods.

On projects of less than 5,000 square yards, or projects with longitudinal tining, the tining and curing devices may be mounted on the same carriage when approved by the Engineer. Operations of this type will be based on satisfactory performance.

Before final texturing, finish the exposed edge of the pavement to a radius of ¼ inch with an edger. Edge the interior longitudinal joints on multiple-lane pavement to a radius of ⅛ inch. Eliminate any tool marks appearing on the slab adjacent to the joints or edge of the slab. Do not disturb the rounding of the corner of the slab.

g. Joints.

(1) General. Construct joints according to the Contract Documents. Failure to construct the joints in the best possible manner will be cause for suspension of work until the cause of the defective work is remedied.

If existing pavement of any type is required to abut with the new pavement, and the termination of the removal is not at an existing joint, make the new joint by sawing the existing pavement full depth with a diamond saw before removal.

The objective is to create or form a plane of weakness in the fresh concrete before uncontrolled or erratic cracking occurs. The following methods are acceptable:

- Use concrete saws to saw all contraction joints no wider than the initial saw cut and to a depth of $D/3 \pm 1/4$ inch. Extreme conditions could exist which make it impracticable to prevent erratic cracking by sawing the joints early. At the onset of the project, devise methods, with the approval of the Engineer, to control this cracking.
- Make a “plastic concrete cut” straight and well defined so it can be sawed out by the saw crew. The “plastic concrete cut” would replace the specified initial saw cut. Suggested procedures could be the use of a stiff metal parting strip, with or without handles that would be gently inserted in the fresh concrete and removed, thereby parting the interlocking coarse aggregate and providing a plane of weakness.
- Cut the fresh concrete with a mason’s trowel and straightedge from a worker’s bridge. It is imperative that the “plastic concrete cut” joint and the second stage saw cut are in the same exact location.
- At the Contractor’s option, “early entry” saws may be used based on satisfactory performance and depth of cut recommended by the equipment manufacturer.
- Procedures to control erratic cracking are not limited to these examples.

Edge any transverse joint requiring hand finishing and edging with a tool having a radius of ⅛ inch. Do not indent the surface of the pavement with the horizontal face of the edger.

(2) Pressure Relief Joints. Install pressure relief joints according to the bridge approach details in the Contract Documents.

Form or saw openings for the joint material approximately 1 ¾ inches wide for the 2-inch joint and approximately 3 ¾ inches wide for the 4-inch joint at the locations shown in the Contract Documents. Use the lubricant adhesive as recommended by the manufacturer of the pressure relief joint material.

Just before the installation of the joint material, clean the faces of the joint by sandblasting, followed by an air blast to clean all dust from joint faces.

The Engineer may approve pre-positioning of the 2-inch material if adequate means are taken to obtain proper placement and retention, and if deformation of the material does not occur when the fresh concrete is placed against it.



(3) Contraction Joints

- **Placement** – Dowels must be perpendicular to roadway centerline and parallel to slab surface.
- **Secure** – place concrete so it will not displace or disarrange the joint assembly.
- **Mark** – identify location of contraction joints to assure the joints are sawed in the proper location.



Common Issue



Common Issue

The tie is too close to the dowel

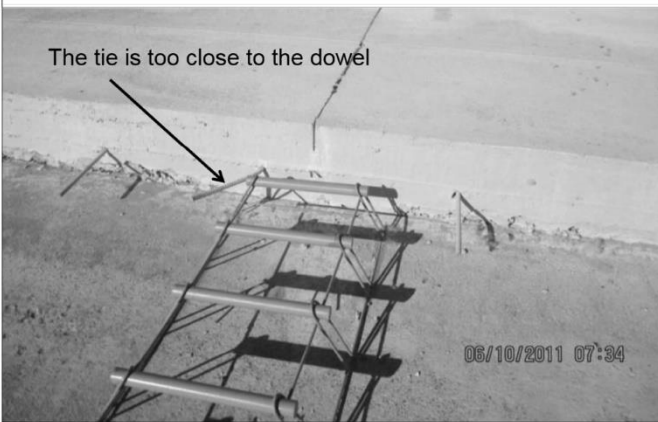

(4) Longitudinal Joints

- **Saw Cut** – provide approved guide lines or devices to cut.
- Automatic tie-bar inserters for longitudinal contraction joints.



www.dot.state.oh.us



www.dot.state.oh.us



(4) Longitudinal Joints

- Longitudinal construction joint
 - Automatic tie-bar inserters, or
 - Drill and epoxy



www.gomaco.com



www.worldhighways.com

Use a foam spacer block beneath the 4-inch joint filler material to maintain the specified grade. The spacer block is an easily compressed foam material cut to fill the void beneath the joint filler.

(3) Contraction Joints. Install contraction joints of the type, dimensions and spacing shown in the Contract Documents.

Stretch a stringline along the centerline of the joint, or otherwise adequately mark it to verify dowel bar joint assembly alignment.

Install the dowel bar joint assembly so the centerline of the assembly is perpendicular to the centerline of the slab, and the dowels lie parallel to the slab surface and slab centerline. Place concrete so it will not displace or disarrange the joint assembly. Mark the location of contraction joints to assure the joints are sawed in the proper location.

(4) Longitudinal Joints. Construct longitudinal joints according to the Contract Documents. When sawed joints are specified or used, provide approved guide lines or devices to cut the longitudinal joint on the true line as shown in the Contract Documents. Perform the sawing of longitudinal joints at a time that will prevent erratic or uncontrolled cracking. When "plastic concrete cut" methods are used, no sawing or widening of the joint will be required to make a sealant reservoir.

(5) Construction Joints. Make a butt construction joint perpendicular to the centerline of the pavement at the close of each day's work, or when the process of depositing concrete is stopped for a length of time sufficient for the concrete to take its initial set. Form this joint by using a clean header having a nominal thickness of 2 inches, and minimum cross-sectional area equal to pavement thickness by pavement width. Cut the header true to the crown of the finished pavement. Accurately set and hold it in place in a plane at right angles to centerline and perpendicular to the surface of the pavement.

Protect the top surface of the header with steel. Securely fasten a trapezoidal piece of metal or wood approximately 2 inches wide and a minimum of 1 inch in depth on the face of the header, along the center of the header to form a grooved or keyed joint.

With approval of the Engineer, the Contractor may pave beyond the joint location a distance to maintain the line and grade. Saw the construction joint when the concrete has hardened. Drill holes for reinforcing tie bars and epoxy the bars in-place. Place fresh concrete against the previously placed concrete taking care to avoid injury to the edge. Vibrate the concrete to obtain an interlocking joint and prevent a honeycombed face of the joint. The additional concrete, removal of debris and other work created by this alternative is at the Contractor's expense.

Unless shown otherwise in the Contract Documents, do not place any construction joint within 5 feet of an expansion, contraction or other construction joint.

(6) Special Joint Construction. Construct special joints as shown in the Contract Documents or as ordered by the Engineer around drainage, utility and other structures located within the concrete pavement boundaries. Hold temporary forms securely in place during the concrete placement operation.

(7) Joint Construction. Construct all joints as shown in the Contract Documents. Repair or replace any curing medium damaged during joint construction. Construct joints as follows:

(a) Induced Plane of Weakness. The first saw cut is a relief cut at the proper joint location, approximately $\frac{1}{8}$ inch wide and to the full joint depth as shown in the Contract Documents ($D/3 \pm \frac{1}{4}$ inch). Make the relief cut as soon as the concrete has hardened enough so that no excess raveling or spalling occurs, but before any random cracks develop. The sequence of the relief sawing is at the Contractor's option, provided all relief sawing is completed before random cracking develops. Use suitable guide lines or devices to cut the joint straight and in the correct location. Repair curing membrane damaged during sawing as directed by the Engineer. See **subsection 501.4g.(1)** for alternate methods to the first stage sawing.

(b) Reservoir Construction. Do not perform widening of the relief joints to full width until the concrete is a minimum of 48 hours old. Delay it longer if the sawing causes raveling of the concrete. If second stage sawing is performed before completion of the curing period, maintain the cure by use of curing tapes, plastic devices or other materials approved by the Engineer. Center the joint groove over the relief cut, and saw it to the dimensions shown in the Contract Documents. Should any spalling of the sawed edges occur that would detrimentally affect the joint seal, patch it with an approved epoxy patching compound and allow it to harden before installing the joint material. Make each patch true to the intended neat lines of the finished cut joint.

(8) Cleaning Joints.



(5) Construction Joints

- Transverse joints (end of day's work)
 - Set header to form a keyed joint
 - Saw in a construction joint, remove excess material and drill and epoxy tie bars.
- Longitudinal joints
 - Use butt or keyed construction

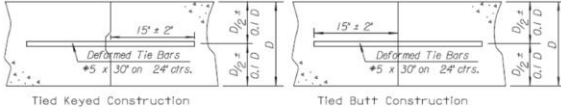

(6) Special Joint Construction

- Per Contract Documents or Engineer directive
 - Around Drainage
 - Around Utilities
 - Around Structures
- Hold temporary forms securely in place



(7) Joint Construction

- **First (Relief) Cut** – Full joint depth ($D/3 \pm 1/4$ in.) and $1/8$ in. wide.
- Perform before cracking occurs (but not too early)

Too Late - typical cracking pattern

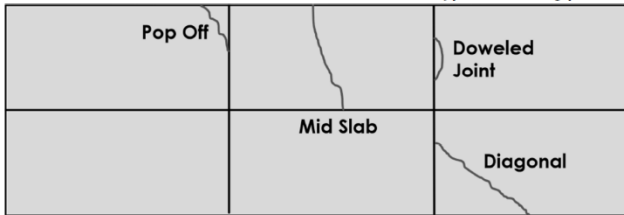

Contraction Joints

No raveling—sawed later in the window



Moderate raveling—sawed early in the window

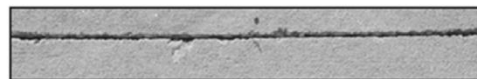

Unacceptable raveling—sawed too early

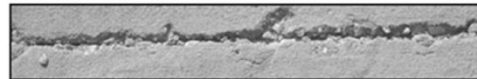

IMCP Manual, CP Tech Center



(7) Joint Construction

- **Reservoir Construction** – Concrete is minimum of 48 hours old
- Saw to dimensions in contract docs
- Standard is $3/8$ " wide by $1 3/4$ " deep

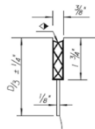

DETAIL OF SEALED CONTRACTION JOINT SAWCUT

Make an initial $1/4$ " saw cut $1/3 \times 1/4$ " depth; the second $3/8$ " saw cut is a separate operation done after concrete has gained sufficient strength to avoid spalling as determined by the Engineer.

Use a foam spacer block beneath the 4-inch joint filler material to maintain the specified grade. The spacer block is an easily compressed foam material cut to fill the void beneath the joint filler.

(3) Contraction Joints. Install contraction joints of the type, dimensions and spacing shown in the Contract Documents.

Stretch a stringline along the centerline of the joint, or otherwise adequately mark it to verify dowel bar joint assembly alignment.

Install the dowel bar joint assembly so the centerline of the assembly is perpendicular to the centerline of the slab, and the dowels lie parallel to the slab surface and slab centerline. Place concrete so it will not displace or disarrange the joint assembly. Mark the location of contraction joints to assure the joints are sawed in the proper location.

(4) Longitudinal Joints. Construct longitudinal joints according to the Contract Documents. When sawed joints are specified or used, provide approved guide lines or devices to cut the longitudinal joint on the true line as shown in the Contract Documents. Perform the sawing of longitudinal joints at a time that will prevent erratic or uncontrolled cracking. When "plastic concrete cut" methods are used, no sawing or widening of the joint will be required to make a sealant reservoir.

(5) Construction Joints. Make a butt construction joint perpendicular to the centerline of the pavement at the close of each day's work, or when the process of depositing concrete is stopped for a length of time sufficient for the concrete to take its initial set. Form this joint by using a clean header having a nominal thickness of 2 inches, and minimum cross-sectional area equal to pavement thickness by pavement width. Cut the header true to the crown of the finished pavement. Accurately set and hold it in place in a plane at right angles to centerline and perpendicular to the surface of the pavement.

Protect the top surface of the header with steel. Securely fasten a trapezoidal piece of metal or wood approximately 2 inches wide and a minimum of 1 inch in depth on the face of the header, along the center of the header to form a grooved or keyed joint.

With approval of the Engineer, the Contractor may pave beyond the joint location a distance to maintain the line and grade. Saw the construction joint when the concrete has hardened. Drill holes for reinforcing tie bars and epoxy the bars in-place. Place fresh concrete against the previously placed concrete taking care to avoid injury to the edge. Vibrate the concrete to obtain an interlocking joint and prevent a honeycombed face of the joint. The additional concrete, removal of debris and other work created by this alternative is at the Contractor's expense.

Unless shown otherwise in the Contract Documents, do not place any construction joint within 5 feet of an expansion, contraction or other construction joint.

(6) Special Joint Construction. Construct special joints as shown in the Contract Documents or as ordered by the Engineer around drainage, utility and other structures located within the concrete pavement boundaries. Hold temporary forms securely in place during the concrete placement operation.

(7) Joint Construction. Construct all joints as shown in the Contract Documents. Repair or replace any curing medium damaged during joint construction. Construct joints as follows:

(a) Induced Plane of Weakness. The first saw cut is a relief cut at the proper joint location, approximately $\frac{1}{8}$ inch wide and to the full joint depth as shown in the Contract Documents ($D/3 \pm \frac{1}{4}$ inch). Make the relief cut as soon as the concrete has hardened enough so that no excess raveling or spalling occurs, but before any random cracks develop. The sequence of the relief sawing is at the Contractor's option, provided all relief sawing is completed before random cracking develops. Use suitable guide lines or devices to cut the joint straight and in the correct location. Repair curing membrane damaged during sawing as directed by the Engineer. See **subsection 501.4g.(1)** for alternate methods to the first stage sawing.

(b) Reservoir Construction. Do not perform widening of the relief joints to full width until the concrete is a minimum of 48 hours old. Delay it longer if the sawing causes raveling of the concrete. If second stage sawing is performed before completion of the curing period, maintain the cure by use of curing tapes, plastic devices or other materials approved by the Engineer. Center the joint groove over the relief cut, and saw it to the dimensions shown in the Contract Documents. Should any spalling of the sawed edges occur that would detrimentally affect the joint seal, patch it with an approved epoxy patching compound and allow it to harden before installing the joint material. Make each patch true to the intended neat lines of the finished cut joint.

(8) Cleaning Joints.



(8) Cleaning Joints

- (a) Remove slurry from joint and immediate area of freshly cut sawed joints
 - Flush with jet of water under pressure
 - Use other necessary tools
- (b) Clean joints with compressed air
 - Maintain equipment to keep oil and water out of air
 - Engineer will inspect daily
- (c) Final Cleaning prior to sealing
 - Air blast
 - Remove incompressibles from joint



(8) Cleaning Joints

- (d) Preformed elastomeric joint seals
 - Clean with water or sandblasting equipment
 - Minimum depth = height of material plus ½ inch
 - Use a multiple pass technique to clean surfaces
 - Remove anything that prevents ready insertion of seal
 - Remove anything that prevents uniform contact with concrete
 - Immediately before installing seal, blow out reservoir with compressed air to remove debris and visible water
 - Note:
 - Seals are held in place by compressive forces and friction
 - They are not held in place by chemical bonding



(9) Sealing Joints

- Seal transverse joints with preformed elastomeric compression joint seals, unless otherwise shown.
- Seal longitudinal joints full depth-select 1
 - Chemically Cured Joint Sealant
 - Hot Joint Sealing Compound
- Technical representative onsite to provide guidance
 - Cleaning
 - Preparation of the joint
 - Installation of the seal
 - Requirement can be waived by Engineer



(9) Sealing Joints

- (a) Cold Applied Chemically Cured Joint Sealants
 - Clean & Dry Joints
 - Pavement age per sealant manufacturer
 - Ambient temperature $\geq 40^{\circ}\text{F}$
 - Apply with approved mechanical device
 - No traffic until
 - Tack free
 - Debris from traffic can't embed sealant



(9) Sealing Joints

- (b) Hot Applied Joint Sealing Compound
 - Clean & Dry Joints
 - Pavement age per sealant manufacturer
 - Clean out application unit
 - No traffic until
 - Tack free
 - Debris from traffic can't embed sealant
- (c) Preformed Elastomeric Joint Seals
 - No Splices, unless phased construction
 - Install with machine to compress seal
 - Apply lubricant
 - Δ length $\leq 3\%$

- (a) Immediately clean freshly cut sawed joints by flushing with a jet of water under pressure and other necessary tools to remove the resulting slurry from the joint and immediate area.
- (b) To clean joints, use air compressors equipped with suitable traps capable of removing all surplus water and oil from the compressed air. The Engineer will check the compressed air for contamination, daily. When contaminated air is found to exist, work will be stopped until suitable adjustments are made, and the air stream is found to be free of contaminants.
- (c) Just before applying the hot or cold joint sealant, complete a final cleaning by air blasting to clean incompressibles from the joint.
- (d) Before installing preformed elastomeric joint seals, use water or sandblasting equipment to clean the seal reservoir of the transverse joint a minimum of the vertical height of the installed elastomeric joint material plus ½ inch measured from the pavement surface. Use a multiple pass technique until the surfaces are free of dirt, curing compound or any residue that might prevent ready insertion of the seal, or uniform contact with the concrete. (Note: These seals are held in place by compressive forces and friction acting on the faces of the joint, not chemical bonding as with other joint sealants.) After final cleaning, and immediately before installing the seal, blow out the joint seal reservoir with compressed air until it is free of debris and visible water.

(9) Sealing Joints. The joint location, size and configuration is shown in the Contract Documents. Use applicable materials to obtain the required joint sealant configuration. Seal transverse pavement joints with preformed elastomeric compression joint seals, unless shown otherwise in the Contract Documents. Seal longitudinal pavement joints full depth with either a cold applied chemically cured joint sealant or a hot joint sealing compound. Use only 1 type of longitudinal joint sealant on a project, unless otherwise approved by the Engineer. Seal joints before opening to traffic. For opening to construction traffic, see **subsection 501.4i.(3)(a)**.

When using cold applied chemically cured joint sealant, hot joint sealing compound or preformed elastomeric compression joint seals, arrange for a technical representative of the manufacturer to be present during installation of the joint seal to provide guidance on cleaning, preparation of the joint and installation of the seal.

Keep the manufacturer's technical representative on the project until Contractor and KDOT personnel have been thoroughly trained in the proper installation of the material. The Engineer may waive this requirement for Contractors that are experienced in installing the type and brand of material being used. Provide the Engineer with a résumé of experience for evaluation.

(a) Cold Applied Chemically Cured Joint Sealants. Do not seal joints until they are clean and dry, and the pavement has attained the age recommended by the manufacturer of the sealant. Do not apply sealant to damp concrete, or install it during inclement weather. Do not apply joint sealant when the ambient air temperature is below 40°F, or as specified by the manufacturer. Place the sealer full depth in close conformity with dimensions shown in the Contract Documents. Any deviation will be cause for rejection of the joint until satisfactory corrective measures are taken.

Apply the joint sealant by an approved mechanical device. Any failure of the joint material in either adhesion or cohesion will be cause for rejection. Repair the joint to the Engineer's satisfaction.

Some cold applied, chemically cured sealants are not self-leveling and will not position properly in the joint under its own weight. Tool the sealant surface as shown in the Contract Documents. Accomplish tooling before a skin forms on the surface. Do not use soap or oil as a tooling aid.

After a joint has been sealed, promptly remove all surplus joint sealer from the pavement or structure surfaces.

Do not permit traffic over sealed joints until the sealer is tack free, or until debris from traffic can not embed into the sealant.

(b) Hot Applied Joint Sealing Compound. Do not seal joints until they are clean and dry, and the pavement has attained the age recommended by the manufacturer of the joint sealing compound. Install joint sealing compound according to the manufacture's recommendations.

Completely clean out the application unit when changing brands of materials, or if the material exhibits any sign of changes in application characteristics, polymer or oil separation, balling or any signs of jelling. If the application unit contains compatible material from a previous project at start-up, provide the Engineer a certification covering the material in the application unit, including the manufacturer, type, etc. Before start-up, completely clean out any material that can not be identified and certified.



(10) Sawed (Non-Sealed) Joints

- (a) Joint Construction
 - Saw $\frac{1}{8}$ " wide by $D/3 \pm \frac{1}{4}$ " deep
 - No excess raveling or spalling
- (b) Cleaning joints
 - Pressurized water jet
 - Other tools to remove slurry
 - Repair curing membrane
- (c) Backer Rod
 - Prevent debris during construction
 - Remove prior to opening to traffic
 - Follow with an air blast
- (d) Repair of Joints
 - Seal Joints with a width $\geq \frac{1}{4}$ "
 - Use hot pour (full width or full panel)



(10) Sawed (Non-Sealed) Joints

- (e) Opening to Traffic
 - Disregard requirement to keep foreign material out of joint
 - Don't need to seal joint to open to public
- (f) Side Roads and Entrance Pavement
 - Also saw no-seal joints
- (g) Curb and Gutter/Valley Gutter
 - Also saw no-seal joints
 - Minimum saw depth is $1\frac{1}{4}$ " below gutter surface
 - If monolithic, same depth as pavement

After a joint has been sealed, promptly remove all surplus joint sealer from the pavement or structure surfaces.

Do not permit traffic over sealed joints until the sealer is tack free, or until debris from traffic can not embed into the sealant.

(c) Preformed Elastomeric Joint Seals. Concrete that has reached an age that permits proper sawing and cleaning without causing deterioration of the joint edges and joint faces, is considered acceptable for seal installation.

Under normal construction procedures, seal transverse joints full width with no splices made in the preformed joint seal. However, under phased construction of widenings, where the lanes placed earlier have been opened to traffic, the preformed joint seal may be spliced at the construction joint. When the existing seal is peeled back to saw the construction joint, clean it, reapply the lubricant/adhesive and reinstall as soon as possible. After the new seal is installed, place the longitudinal joint sealant through the intersection with the transverse joint, with the transverse seals butted in. Place the longitudinal sealant to encase and seal the ends of the preformed seals.

Install the joint seal with a machine especially designed to compress and install the sealant in an upright position, without cutting, nicking, distorting or otherwise damaging the seal. Apply lubricant to the concrete or the preformed seal (or both), and install the seal in a substantially compressed condition. Place the top of the seal at a depth below the finished surface of the pavement, recommended by the manufacturer.

Use a method of installation such that the joint seal will not be stretched or compressed longitudinally more than 3% of the length, unless stated otherwise in the manufacturer's instructions. The method of installation will be checked for stretching or compression by comparing the distance between 2 marks on the surface of the seal measured before and after the installation. If the check indicates stretching or compression beyond the limits stated above, modify the method of installation to correct the situation. The Contractor may proceed slightly out of specification for a short distance under the supervision of the manufacturer's technical representative, while making corrections and adjustments to return to specification limits. This material may remain in place, provided the stretching does not exceed 5%, and the Contractor makes a good faith effort to correct the problem. Once the machine is in proper adjustment and the installation is proceeding satisfactorily, further checks (approximately every 100 joints) will be made to verify proper installation.

Remove any joint seal not conforming to the above stated limits of installation and replace with new material. After being removed for any reason, no seal may be reused.

(10) Sawed (Non-Sealed) Joints.

(a) Joint Construction. The joint location, size and configuration are shown in the Contract Documents. Use concrete saws to saw all joints a nominal 1/8 inch wide to the full joint depth, $D/3 \pm 1/4$ inch, unless shown otherwise in the Contract Documents.

Make the saw cut as soon as the concrete has hardened enough so that no excess raveling or spalling occurs, but before any random cracks develop. The sequence of the sawing is at the Contractor's option, provided all sawing is completed before random cracking develops. Use suitable guide lines or devices to cut the joint straight and in the correct location.

(b) Cleaning Joints. Immediately clean freshly cut sawed joints by flushing with a jet of water under pressure and other necessary tools to remove the resulting slurry from the joint and immediate area. Repair curing membrane damaged during sawing and cleaning, as directed by the Engineer.

(c) Backer Rod. Install and maintain backer rod (of a size sufficient to prevent debris from entering the joint) in the joint. When major construction traffic is no longer driving on the pavement, and prior to opening to the public, remove the backer rod, and follow with an air blast to remove any debris.

(d) Repair of Joints. If the sawed joint is $\geq 1/4$ inch, seal the joint using Hot Applied Joint Sealing Compound, according to **subsections 501.4g.(7) thru (9)(b)**. Seal transverse joints the full width of pavement. Seal longitudinal joints the full length of the panel. If the joint can not be properly sealed, see **subsection 501.4k**.

(e) Opening to Traffic. When no joints require sealing, disregard **subsection 501.4i.(3)(a)**, third bullet and **501.4i.(3)(b)**.

(f) Side Roads and Entrance Pavement. If the PCCP is designated with sawed (non-sealed joints), construct the side road and entrance pavement joints according to **subsection 501.4g.(10)**, unless otherwise specified in the Contract Documents.

(g) Curb and Gutter/Valley Gutter. Unless specified otherwise in the Contract Documents, if the PCCP is designated with sawed (non-sealed) joints, construct the curb and gutter/valley gutter joints according to **subsections 501.4g.(10)(a) thru (c)** with the following exception: saw to a depth a minimum of 1 ¼ inches below the surface of the gutter. If the curb and gutter is placed monolithically with the pavement, saw to the same depth as the pavement.

h. Hand Finishing. Hold hand finishing methods to a minimum. Generally, hand methods of placement and finishing will be permitted as follows:

- For pavement when a breakdown of some portion of the paving train occurs, making the hand finishing of that portion of the concrete already in place necessary.
- For pavement lanes that may be too narrow or a length too short to accommodate a full paving spread.
- For all irregular shaped areas.
- For special approach sections to bridges, widened portions at bridges, intersections and sections widened beyond traffic lanes.
- When the dimensions of the work make the use of a complete power operated paving impossible, or impracticable.

For uniform width areas or transition width areas using false forms, finish handwork with a mechanical finishing machine or approved vibrating screed, whenever possible.

Use spud hand vibrators on any area considered impracticable to vibrate with a vibrating screed. Approved metal or wood floats may be used if needed to help close an open or porous surface condition.

Continue the operation of consolidation and screeding or striking off the concrete until the concrete is uniformly consolidated and the surface is true to line, grade and cross-section.

After the pavement has been properly struck off, straightedge the pavement for trueness and finish it. Use a burlap drag to remove surface straightedge marks. The burlap drag may be pulled by hand, but the results shall be similar to that on the mainline pavement.

Manual methods may be used for texturing hand finished pavement areas. Where applicable, the tined texture applies. Use a metal comb with dimensions and spacing shown in **subsection 154.7c**. Obtain a finished textured surface similar to that produced mechanically.

On miscellaneous areas such as entrance pavement, median pavement and gore areas, texturing with the metal comb may be eliminated. Final finish may be attained by the use of a drag that consists of a seamless strip of damp burlap, cotton fabric or other suitable material capable of producing a uniform surface of gritty texture.

i. Protection and Curing of Concrete. Cure the pavement by using burlap, liquid membrane-forming compounds, white polyethylene sheeting, concrete curing blankets or reinforced white polyethylene sheeting. Failure to provide proper curing is cause for immediate suspension of the concreting operations.

(1) Burlap, Concrete Curing Blankets, White Polyethylene Sheeting and Reinforced White Polyethylene Sheeting. Place the curing material on the pavement immediately after the pavement has been finished, and the concrete has hardened sufficiently to avoid harmful marring of the surface, yet early enough to prevent undue loss of moisture from the concrete. If the pavement becomes dry before the curing material is placed, moisten the concrete with a fine spray of water. Dampen burlap and place on the surface. Place burlap-polyethylene blankets with the dampened burlap side down. Keep burlap damp throughout the entire curing period.

Lap adjacent units of curing materials approximately 18 inches. Upon removal of the forms, extend the material to completely cover the full depth of the exposed pavement.

Weigh the curing material down using continuous windrows of earth placed along the sides and edges of the pavement and transversely across the pavement on the laps to cause the material to remain in contact with the covered surface throughout the curing period. Other methods may be used with approval of the Engineer.

Walking on the pavement surface to place the curing material is prohibited. Walking on the curing material is prohibited until the pavement has cured sufficiently to prevent damage to the surface.

SECTION 501.4J-M CONSTRUCTION REQUIREMENTS



501.4 CONSTRUCTION REQUIREMENTS

- a. Preparation of Subgrade (500-4)
- b. Slip Form Paving (500-5)
- c. Placing Reinforcement (500-6)
- d. Consolidation and Finishing (500-6)
- e. Fixed Form Paving (500-7)
- f. Texturing (500-8)
- g. Joints (500-8)
- h. Hand Finishing (500-12)
- i. Protection and Curing of Concrete (500-12)
- j. Cold Weather Limitations (500-13)
- k. Repair of Defective Slabs (500-13)
- l. Protection of Pavement from Rain (500-16)
- m. Pavement Smoothness (500-16)



501.4j. Cold Weather Limitations

- See 401.8b.(2) Placing Concrete in Cold Weather.
- Stop when descending ambient air temperature reaches 40°F.
- May begin when ascending ambient air temperature reaches 35°F and is expected to exceed 40°F.



501.4j. Cold Weather Limitations

- When Engineer Permits Cold Weather Concrete
 - Aggregates may be heated by steam or dry heat
 - Heat Aggregates uniformly
 - May use methods not detrimental to aggregates
 - Do not use live steam on or through bins
 - Maintain mix temperature between 50°F – 90°F at time of placing
 - Do not continue concrete operations if ambient air temperature is less than 20°F



j. Cold Weather Limitations

- If Ambient air temperature is $\leq 35^{\circ}\text{F}$, the Engineer may require that the water and aggregates be heated to between 70°F and 150°F
- Do not place concrete on frozen subgrade
- Do not use frozen aggregates
- Use of Supplemental Cementitious Materials (SCM)
 - Potential longer set time
 - Slower strength gain
 - May effect statistics and moving averages of mix properties



k. Repair of Defective Pavement Slabs

1. Repair of Spalls (pg. 500-13)
2. Repair of Cracks in New Reinforced, Dowel Jointed PCCP (pg. 500-14)
3. Repair of Cracks in Dowel Jointed PCCP (and Mainline Plain PCCP) (pg. 500-15)
4. Repair of Cracks in Shoulder Plain PCCP (pg. 500-16)



General

General Considerations

- Contractor responsibility to repair at no cost to KDOT.
- Completely remove and replace pavement panels with transverse and longitudinal cracks.
- Seal the joints of the repaired or replaced panels.

Special Provision 15-04005: Section 401.8b

b. Placement Limitations.

(1) Placing Concrete at Night. Do not mix, place or finish concrete without sufficient natural light, unless an adequate, artificial lighting system approved by the Engineer is provided.

(2) Placing Concrete in Cold Weather. Unless authorized by the Engineer, discontinue mixing and concreting operations when the descending ambient air temperature reaches 40°F. Do not begin concreting operations until an ascending ambient air temperature reaches 35°F and is expected to exceed 40°F.

If the Engineer permits placing concrete during cold weather, aggregates may be heated by either steam or dry heat system before placing them in the mixer. Use an apparatus that heats the mass uniformly and is so arranged as to preclude the possible occurrence of overheated areas which might injure the materials. Do not heat aggregates directly by gas or oil flame or on sheet metal over fire. Aggregates that are heated in bins, by steam-coil or water-coil heating, or by other methods not detrimental to the aggregates may be used. The use of live steam on or through binned aggregates is prohibited. Unless otherwise authorized, maintain the temperature of the mixed concrete between 50 to 90°F at the time of placing. Do not, under any circumstances, continue concrete operations if the ambient air temperature is less than 20°F.

If the ambient air temperature is 35°F or less at the time the concrete is placed, the Engineer may require that the water and the aggregates be heated to between 70 and 150°F.

Do not place concrete on frozen subgrade or use frozen aggregates in the concrete.

Make adjustments for potential longer set time and slower strength gain for concrete with SCMs. Adjust minimum time requirements as stated in **SECTION 710** for concrete used in structures. For concrete paving, be aware of the effect that the use of SCMs (except silica fume) may have on the statistics and moving averages.

Section 501.4j

...

j. Cold Weather Limitations. If concrete is placed in cold weather, comply with **SECTION 401**.

k. Repair of Defective Pavement Slabs. It is the responsibility of the Contractor to repair any spalled, cracked or broken panels as specified hereinafter at no cost to KDOT. Completely remove and replace pavement panels (area between contraction joint and contraction joint) containing both transverse and longitudinal cracks (separating the panel into 4 or more parts) through the full depth of the slab.

Properly seal the joints of the repaired or replaced panels.

(1) Repair of Spalls.



(1) Spalling

- All spall patches $\geq 1 \text{ ft}^2$ (min: 1 ft x 1 ft)
- Repair depends on the size of the spall width: $\frac{1}{4}$ to $\frac{1}{2}$ in., $\frac{1}{2}$ to 1 in., >1 in.

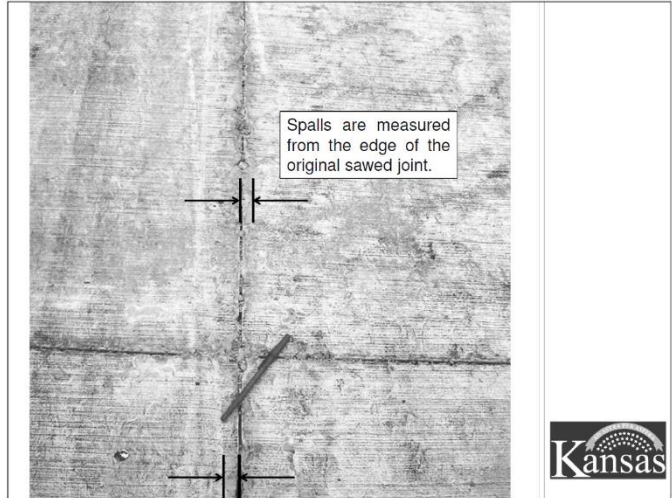
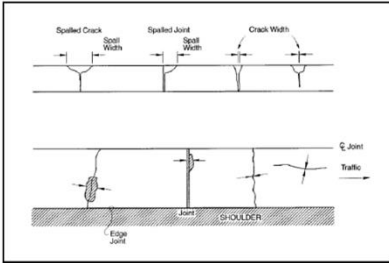

(1) Spalling

Size of Spall	Repair Required
$< \frac{1}{4}$ in.	None
$\frac{1}{4}$ to $\frac{1}{2}$ in.	Repair with hot pour
$\frac{1}{2}$ to 1 in.	Blast clean and repair with epoxy patch material.
>1 in.	Cut and remove effected area to a min. depth of 2 in. and repair with an approved patching material. Maintain working joints.



(2) Repair of Reinforced, Dowel Jointed PCCP

(a) Transverse and Diagonal Cracks

(b) Longitudinal Cracks

(b) Longitudinal Cracks

- Single longitudinal crack falls within a panel, no corrective work required.
- Two full-depth cracks fall within a panel, remove and replace the panel



fhwa.dot.gov



(2) Repair of Reinforced, Dowel Jointed PCCP

(a) Transverse or Diagonal Cracks

- Single full depth crack falls within middle $\frac{1}{3}$ – no corrective action req'd.
- Two full-depth cracks fall within middle $\frac{1}{3}$ – remove and replace panel.

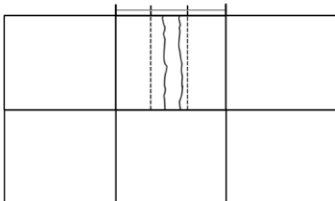

(2) Repair of Reinforced, Dowel Jointed PCCP

(a) Transverse or Diagonal Cracks

- Remove cracks outside of the middle $\frac{1}{3}$ of the panel (6 ft. minimum) .
- If the location of this crack is within 6 ft. of a mid-panel crack, remove that as well.

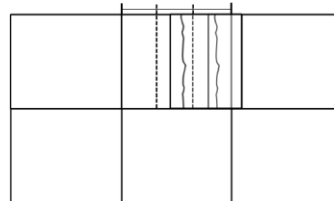

- In no case shall an individual patch of a spall be less than 1 square foot with no dimension less than 1 foot.
- For spalls greater than ¼ inch and less than or equal to ½ inch from edge of the original sawed joint, repair with hot pour.
- For spalls greater than ½ inch and less than or equal to 1 inch from the edge of the original sawed joint, blast clean and repair with epoxy patch material.
- For spalls greater than 1 inch from the edge of original sawed joint, repair by making a saw cut a minimum of 1 inch outside the spalled area to a minimum depth of 2 inches. The interior angles formed by the intersection of adjacent sides of the patch shall be a minimum of 60°. When the spalled area abuts a joint, make the saw cut to a depth of 2 inches or 1/6 the slab thickness, whichever is greater. Chip out the concrete between the saw cut and the joint or primary crack to solid concrete. Do not use chipping hammers greater than 15 pounds. Thoroughly clean all loose material from the formed cavity. Apply a coat of an approved concrete bonding epoxy to the dry, cleaned surface of all sides of the cavity, except the joint. Apply the epoxy by scrubbing the material into the surface with a stiff bristle brush. Place portland cement concrete, epoxy resin concrete or mortar, immediately following application of the epoxy, according to the manufacturer's recommendations. If the spalled area to be patched abuts a working joint, use an insert or other bond breaking medium during the repair work to maintain working joints. Remove and replace major honeycombed areas found after removal of the forms. Removed areas or sections so removed shall be a minimum of 6 feet in length if less than full width of the lane involved. When it is necessary to remove a section of pavement, also remove and replace any remaining portion of the slab adjacent to the joints that is less than 6 feet in length.

(2) Repair of Cracks in New Reinforced, Dowel Jointed PCCP.

(a) Transverse and Diagonal Cracks.

(i) Full Depth.

- When a single full-depth transverse crack falls within the middle ⅓ of the panel, no corrective work will be required.
- Should a second full-depth crack develop within the middle ⅓ of the panel, remove and replace the panel to the nearest planned contraction joint, eliminating both cracks. If the location of the mid-panel full-depth crack is within 6 feet of the boundaries of the area to be repaired, extend the area to be repaired to include the mid-panel crack.
- When any portion of a full-depth crack falls outside the middle ⅓ of the panel, remove and replace the portion of panel between the contraction joint and the crack. Make 1 full-depth saw cut parallel to the contraction joint on the mid-panel side of the crack to be removed. Make another cut in the adjacent panel, parallel to the contraction joint, clear of the basket assembly, but not less than 6 feet from the first cut. Remove the cracked section and basket assembly. Drill holes in both sawed faces, and insert bars to make 2 contraction joints. Use dowels of the same size and spaced the same distance as those shown in the Contract Documents. Drill bar holes ¼ inch ± 0.05 inch larger than the diameter of the bar and fill them with epoxy or grout and insert the new dowel. Support the free ends of the bars parallel to the pavement surface until the epoxy or grout has set, obtaining proper alignment of the bar. Apply grease or an approved bond breaker to the free ends.
- If the boundaries of consecutive areas to be repaired are less than 6 feet apart, also remove and replace the areas between the patches.
- Saw off the longitudinal joint tie bars at the longitudinal joint. Drill holes midway between the existing bars and insert tie bars to make a new tied longitudinal hinged joint. Use tie bars of the same size and spacing as those in the Contract Documents. Drill bar holes ¼ inch ± 0.05 inch larger than the diameter of the bar and fill them with epoxy or grout and insert new tie bars.

(b) Longitudinal Cracks. When a single longitudinal crack falls within a panel, no corrective work will be required.



(3) Repair of Non-Reinforced, Dowel Jointed PCCP

(a) Transverse and Diagonal Cracks

- Remove and replace or Dowel Bar Retrofit-Repair (Section 504).
- Remove and replace – same procedure as for reinforced PCCP.

Full Depth

- Tie Bar Insertion Repair (Section 505) may be used for *partial-depth cracks* (verified by coring).



(3) Repair of Non-Reinforced, Dowel Jointed PCCP

Number of Cracked Panels Per Lane Mile	Repair Required
≤4	Remove and Replace or Dowel Bar Retrofit
5 to 18	Same as above except if 2 consecutive panels are cracked remove and replace.
>18	Remove and Replace until ¼ mile segment has less than 4 panels cracked. Then repair or replace.



Repairs Details



Dowel Repair Details

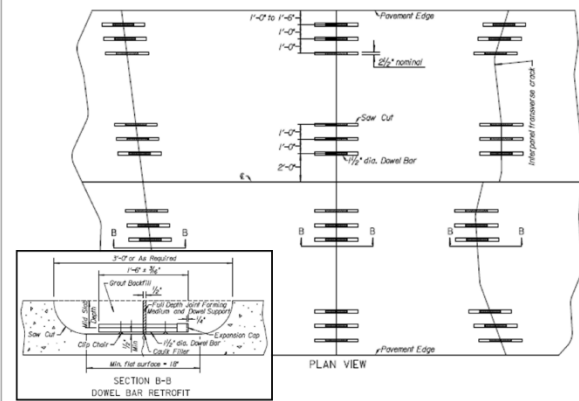

Tie-Bar Repair Details

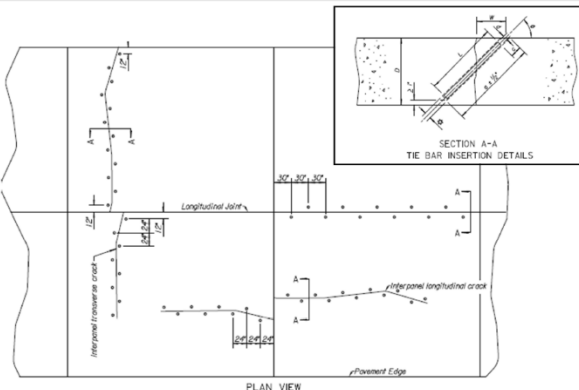

(3) Repair of Non-Reinforced, Dowel Jointed PCCP

(b) Longitudinal Cracks

- Within 3-in. of longitudinal joint – partial depth patch (same as for spalls)
- Within 3 to 6-in. – fill the entire planned longitudinal joint with epoxy
- More than 6-in. – remove and replace or Tie Bar Insertion Repair

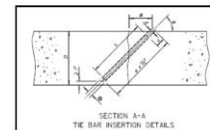

When a second full-depth longitudinal crack falls within a panel, remove and replace the panel to the nearest planned contraction joint, eliminating both cracks.

(3) Repair of Cracks in both New Non-reinforced Dowel Jointed PCCP and Mainline Plain PCCP.

(a) Transverse and Diagonal Cracks.

(i) Full Depth.

- If a maximum of 4 panels per any lane mile has a crack, repair according to **SECTION 504 – DOWEL BAR RETROFIT-REPAIR**, or remove and replace the pavement.
- If 5 to 18 of the panels per any lane mile has a crack, repair according to **SECTION 504 – DOWEL BAR RETROFIT-REPAIR**. When 2 consecutive panels have a crack, remove and replace the panels from contraction joint to contraction joint.
- If more than 18 of the panels per any lane mile have a crack, remove and replace the pavement bounded by the cracks in that segment. Remove and replace until ¼ mile segment has less than 4 panels cracked, then repair or replace.

(ii) Partial Depth. If coring (at no additional cost to KDOT) verifies the transverse cracks are not full depth, repairs may be made by **SECTION 505 – TIE BAR INSERTION-REPAIR**.

(iii) When required or at the Contractor's option, remove and replace pavement panels containing any transverse or diagonal crack according to the following:

- Make a full-depth saw cut in the abutting panel nearest to the crack, parallel to the contraction joint, just clear of the basket assembly to allow the existing dowel basket assembly to be completely removed. Make a second saw cut parallel with the contraction joint on the opposite side of the crack away from the contraction joint. For plain PCCP, make the saw cut at the joint nearest to the crack. Make the second saw cut opposite the first cut a minimum of 6 feet from the first saw cut to include the crack. Remove the resulting area.
- The minimum longitudinal length of a patch is 6 feet.
- Do not permit a patch to fall within 6 feet of a contraction joint.
- The maximum distance between doweled/non-doweled contraction joints is 18 feet.
- Drill holes and insert dowel bars to make new contraction joints within the vertical faces of both newly created panel ends. Use dowels of the same size and spaced the same distance as shown in the Contract Documents. Drill bar holes ¼ inch ± 0.05 inch larger than the diameter of the bar and fill with epoxy or 7ortland cement grout and insert the new dowel. Support the free ends of the bars until the epoxy or grout has set to obtain proper alignment of the bar. Apply grease or an approved bond breaker to the free ends. Do not use dowel bars in plain PCCP.
- Saw off the longitudinal joint tie bars at the longitudinal joint. Drill holes midway between the existing bars and insert tie bars to make a new tied longitudinal hinged joint. Do not place new tie bars within 12 inches of doweled joint. Use tie bars of the same size and spacing as those in the Contract Documents. Drill bar holes ¼ inch ± 0.05 inch larger than the diameter of the bar and fill them with epoxy or grout and insert new tie bars.

(b) Longitudinal Cracks. Repair or remove and replace pavement panels that contain a single longitudinal crack, according to the following:

- Repair longitudinal cracks that are within 3 inches of the planned longitudinal joint for their entire length with a partial depth patch as specified for spall in **subsection 501.4k.(1)**, except make the transverse dimension of the patch 6 inches and saw cuts to $D/3 \pm ¼$ inch.
- For longitudinal cracks between 3 and 6 inches from the planned longitudinal joint, fill the entire planned longitudinal joint full depth with epoxy through the length of the longitudinal crack.
- Repair longitudinal cracks that are 6 inches or more from the planned longitudinal joint by removing and replacing pavement panels, or repair pavement by **SECTION 505 – TIE BAR INSERTION-REPAIR**.



(4) Repair of Cracks in Shoulder Plain PCCP

(a) Transverse and Diagonal Cracks

- Rout and seal cracks within 3 ft. of transverse contraction joints.
- Remove and replace when there are 2 or more cracks.

(b) Longitudinal Cracks

- Tie Bar Insertion Repair for 1 crack
- Remove and Replace when there are 2 or more cracks.



(l) Protection from Rain

- Have an approved Plan
 - Include protective covering and side forms
 - Use Polyethylene, burlap or other covering materials
 - Side forms
 - Wood or steel
 - Depth a minimum of the thickness of the pavement
 - Specify storage location so Engineer can review
 - Include the type and amount of protective materials
 - Include methods proposed to protect the pavement



(l) Protection from Rain

- Imminent Rain
 - Stop all paving operations
 - Initiate the Protection Plan
 - Extend the covering back to the point where the rain will not indent the surface
 - Exercise care to prevent unnecessary damage to the surface with the covering.



(m) Pavement Smoothness

- Pay According to Section 503
 - Beyond Scope of Class
 - Table 503-3 has Pay Adjustments

Average Profile Index (in./mi. per lane per 0.1 mi. section)	Contract Price Adjustment (per 0.1 mi. section per lane)
6.0 or less	+\$1000.00
6.0 to 10.0	+\$835.00
10.1 to 15.0	+\$625.00
15.1 to 18.0	+\$310.00
18.1 to 30.0	0.00
30.1 to 40.0	0.00*
40.1 or more	-\$615.00*

Remove and replace pavement panels that contain 2 or more longitudinal cracks.

(4) Repair of Cracks in Shoulder Plain PCCP.

(a) Transverse and Diagonal Cracks.

- When a single transverse crack falls within a panel and is within 3 feet of the transverse contraction joint, fill the contraction joint according to the Contract Documents and rout and seal the crack.
- When 2 or more transverse cracks fall within a panel, remove and replace the panels.

(b) Longitudinal Cracks.

- When a single longitudinal crack falls within a panel, repair pavement by **SECTION 505 – TIE BAR INSERTION-REPAIR**.
- When 2 or more longitudinal cracks fall within a panel, remove and replace the panels.

l. Protection of Pavement from Rain. Before placing PCCP, prepare and submit to the Engineer for approval, a Protection Plan to address the onset of rain during concrete placement. As a minimum, the plan shall include protective covering and side forms available at the project site at all times to protect the surfaces and edges of the newly placed concrete pavement. Polyethylene, burlap or other covering materials may be used. Side forms may be of wood or steel and shall have a depth a minimum of the thickness of the pavement. Specify the location of the storage site in order that a review of the protective materials may be conducted by the Engineer.

Include the type and amount of protective materials as well as the methods proposed to protect the pavement.

When rain appears imminent, stop all paving operations and initiate the Protection Plan. Extend the covering back to the point where the rain will not indent the surface. Exercise care to prevent unnecessary damage to the surface with the covering.

m. Pavement Smoothness. Evaluate pavement smoothness for pay according to **SECTION 503**.

500-16

.....
503.4 MEASUREMENT AND PAYMENT

Pay adjustments will be based on the initial average profile index determined for the "sections" prior to performing any corrective work, unless the surface of the entire project is continuously ground.

If the Contractor elects or is required by **TABLE 503-2** to continuously grind the entire project, pay adjustments will be based on the average profile index determined after all grinding is performed.

If the Contractor elects to remove and replace the sections, the Contractor will be paid the price adjustment that corresponds to the initial average profile index obtained on the pavement sections after replacement.

The Engineer will apply the contract price adjustment according to **TABLE 503-3**.

Payments made for "Concrete Pavement Smoothness" will be shown as an added item to the contract.

TABLE 503-3: CONCRETE PAVEMENT SMOOTHNESS PAY ADJUSTMENT NEW CONSTRUCTION	
Average Profile Index (in./mi. per lane per 0.1 mi. section)	Contract Price Adjustment (per 0.1 mi. section per lane)
6.0 or less	+\$1000.00
6.0 to 10.0	+\$835.00
10.1 to 15.0	+\$625.00
15.1 to 18.0	+\$310.00
18.1 to 30.0	0.00
30.1 to 40.0	0.00*
40.1 or more	-\$615.00*

*Correct to 30.0 inch/mile (40.0 in./mi. as noted in **TABLE 503-1**).

The pay adjustments in **TABLE 503-3** are for 12-inch thick hot mix asphalt and 8-inch thick portland cement concrete pavements. Pay adjustments for pavements of different thicknesses will be reduced or increased proportionally, based on the typical section for the extent. (i.e. pay adjustment for a 12-inch portland cement concrete pavement is equal to the adjustment from the TABLE multiplied by 1.5).

106.3 SAMPLING, TESTING, AND CITED SPECIFICATIONS

The Engineer, Inspector, or both may inspect, test, and approve or reject all materials before, during, and after incorporation into the work.

The Engineer or Inspector will take or direct the Contractor to take all samples, except the Contractor's process control and QC samples. Sample and test the process control and QC samples. Upon request, KDOT will provide copies of test results KDOT performed. When the Contract Documents refer to an undated specification, standard, or test method that AASHTO, ASTM, GSA, or another recognized national technical association has adopted, the reference means the most recent published (including interim or tentative) specification, standard, or test method in effect on the Letting date.

The Secretary will pay the cost of all inspection and testing the Engineer or Inspectors undertake.

The Contractor shall:

- pay the cost of all materials that KDOT or the Contractor uses for sample testing;
- pay the cost of all testing the Contractor performs on quality control/quality assurance (QC/QA) projects;
- include such costs in the QC/QA bid item; and
- pay the costs of testing KDOT performs on materials that exceed contract quantities and testing that is requested but the Engineer or Inspector deems unnecessary.

If the Contract Documents specify one manufacturer's product, the Contractor may request the use of a product of another manufacturer unless the Contract Documents prohibit substitution. Submit the request to the Engineer and include:

- a complete description of the item;
- an explanation of how the alternate product meets the same standards as the product the Contract Documents specify;
- copies of shop drawings, catalog cuts, or both; and
- test reports or other descriptive literature, completely illustrating such items.

The Engineer alone determines whether the alternate product is acceptable.

Provide the Engineer required test reports or certifications for all materials incorporated into the work.

The Engineer may waive the testing requirements of small quantities of materials if the material is incidental to the work, a recognized commercial brand, or obtained from sources having a history of adequate QC.

On projects where Buy America requirements apply, note on shop drawings and catalog cuts that steel and iron used meets Buy America, unless otherwise specified.

106.4 CONTRACTOR QUALITY CONTROL REQUIREMENTS FOR QUALITY CONTROL/QUALITY ASSURANCE (QC/QA) PROJECTS

This **subsection 106.4** outlines general requirements for all types of QC/QA projects. Consult the particular section or subsection to obtain detailed process and QC requirements for a particular type of construction.

a. General.

- (1) Provide personnel and equipment that meet Part V QC testing procedures.
- (2) Provide the Engineer all reports, records, and diaries developed during construction activities. These documents are KDOT's property.

b. Quality Control Plan.

(1) At the pre-construction conference, submit in writing a Quality Control Plan (QC Plan) that meets Part V testing procedures (partially detailed below) for the Engineer's review and approval.

(a) List the names and phone numbers of all individuals and alternates responsible for QC administration and inspection. For each particular type of construction, supply one or more individuals who have complied with the technical certification requirements detailed in "KDOT Policy and Procedure Manual for The Certified Inspection and Testing Training (CIT) Program Manual". Only certified technicians may perform testing used for materials acceptance.

- The certification requirement applies whether the personnel belong to the Contractor's QC organization or private testing firms.

106 – CONTROL OF MATERIALS

- Obtain the "KDOT Certified Technician Manual" from the KDOT Bureau of Materials and Research.

(b) On the organizational chart, show the specified lines of authority for both mix design and QC operations during production.

(2) The Engineer's review and approval of the Contractor's QC Plan are for KDOT's benefit, not to ensure QC results. This review and approval is not a substitute for the Contractor's obligation to control quality.

c. Testing Facilities.

(1) Locate the QC testing facility either at the plant site or adjacent to the Project site and in a place that is readily accessible to the Project. Before beginning mixture production, obtain the Engineer's approval of the testing facility, including the facility's location and the testing equipment. Obtain the District Materials Engineer's approval to put the testing facility in a location other than the plant site or adjacent to the Project site. Provide the QC personnel the space and testing equipment needed to meet Part V.

(2) Calibrate and correlate the testing equipment with prescribed procedures and conduct tests according to Part V testing procedures.

(3) To facilitate communication between the Contractor and the Engineer, equip the QC testing facility with the following:

(a) A telephone with a private line for the QC personnel's exclusive use.

(b) A copying machine for the Contractor's, Engineer's, and Inspector's use.

(4) In the testing facility, post a copy of the organizational chart from the QC Plan.

(5) Allow the Engineer access to the testing facility to observe testing procedures, calculations, test documentation, and plotting of test results among other items.

(6) If the Contract Documents require one, locate the Field Office and Laboratory (Lab) near the Contractor's testing facility. See **SECTION 803**.

d. Testing, Recording, and Data Presentation Requirements.

(1) Take all test samples at random locations, at the frequencies designated in the approved QC Plan, and at the rates specified in the KDOT Sampling and Testing Frequency Chart, Part V. Provide the Inspector with the random locations or frequencies before going to the job site to sample or test. The Engineer reserves the right to generate the random locations, frequencies, or both. If KDOT generates the random locations or frequencies, KDOT will provide notification prior to the sampling time.

(2) Record all original documentation in a bound field book or other KDOT approved bound record and turn over to KDOT at the end of the Project. Record and document all test results and calculations on data sheets KDOT has approved. Record specific test results on a daily summary sheet KDOT has approved. Base moving averages on 4 consecutive test results. Include in the Daily Quality Control Summary Sheet a description of quality control actions taken. Post and keep current QC charts showing both individual test results and moving average values. As a minimum, plot the single test values and the 4-test moving average values, as applicable, on KDOT-approved control charts. Keep control charts current on an ongoing basis. Plot results and limits as follows:

- individual test results for each test point in black. Connect those points with a solid black line;
- moving average for each test variable in red. Starting with the fourth test, connect those points with a dashed red line;
- KDOT verification test results with green asterisks; and
- specification working range limits for single test results with a green ink dotted line and for the 4-point moving average results with a green ink solid line.

(3) Store and retain all QC and verification samples for 7 business days.

(4) Provide test data as specified in the appropriate QC/QA construction specification.

e. Inspection by KDOT.

(1) The Engineer and Inspector reserve the right to run any test at any time to determine contract compliance.

(2) The Engineer or Inspector will inspect aggregates at the point of production for approved deposits, ledges, and beds. Do not produce aggregates from non-approved deposits, ledges, or beds. Immediately remove from the stockpile aggregates obtained from non-approved deposits, ledges, or beds.

106 – CONTROL OF MATERIALS

(3) The Engineer or Inspector may test aggregates for acceptance at the point of usage. Remove and replace, repair, or otherwise correct, at the Contractor's expense, work incorporating aggregates from non-approved sources.

106.5 CONTRACTOR'S PROCESS CONTROL FOR NON-QC/QA PROJECTS

a. General.

- (1) Provide and maintain an adequate process control system.
 - Perform all inspections and tests necessary to meet the Contract Documents; and
 - Provide materials and formulate design mixes that meet the Contract Documents.
- (2) Assume responsibility for the process control of all aggregate and aggregate combinations during production, handling, stockpiling, blending, mixing, and placing operations.
- (3) Perform all tests by personnel certified under the Certified Inspection and Testing Training (CIT₂) Program. Personnel may be certified by another program with approval of the Engineering Technician Training Coordinator.

b. Process Control Plan.

- (1) Before beginning material production, submit in writing a Process Control Plan for the Engineer's review and approval. In the Process Control Plan, include the following:
 - Sampling and testing frequencies, sampling locations, sampling and testing methods, and other inspections required to maintain the Process Control Plan. Upon request, KDOT will provide a recommended process control sampling and testing frequencies chart;
 - Procedures to determine gradation, plasticity index, and deleterious substance content of all aggregates the Contractor may use;
 - Procedures for inspecting stockpiles for separation, contamination, or segregation;
 - For cold feed bins, include calibration procedures for setting cold feeds including observation of cold feed operation for uniformity;
 - For hot bins, include procedures to determine the gradation of aggregate in each bin. Determine the theoretical combined grading and calibrate the hot feed settings to provide the required material;
 - For batch plants, determine the percent or weight to be used from each bin to assure compliance with the Approved HMA Mix Design or Approved Concrete Mix Design; and
 - For continuous flow plants, establish a gate calibration chart for each bin. Determine gate settings for each bin to assure compliance with the Approved HMA Mix Design or Approved Concrete Mix Design.

(2) KDOT considers the guidelines set forth in **subsection 106.5b.(1)** as customary activities necessary to control the production of materials or mixes at an acceptable quality level. The activity KDOT requires depends on the type of process or materials the Contractor is producing. The frequency of these activities also varies with the process and the materials.

(3) The Engineer's review and approval of the Contractor's Process Control Plan are for KDOT's benefit, not to ensure Contractor quality processes. This review and approval is not a substitute for the Contractor's obligation to control processes.

c. Sampling and Testing. Use the same process control sampling, testing methods, and procedures that KDOT uses. Consult Part V for the Kansas Test (KT) Methods and for a Sampling and Testing Frequency Chart that the Contractor or producer may use as a material acceptance guide when developing the Process Control Plan. Advise producers supplying material for non-QC/QA projects to find the minimum required sampling and testing frequencies in Part V.

d. Test Reports. Maintain a file of all process control tests and provide this file to the Engineer at the Engineer's request.

106 – CONTROL OF MATERIALS

e. Inspection by KDOT.

(1) The Engineer and Inspector reserve the right to run any test at any time to determine contract compliance.

(2) The Engineer or Inspector will inspect aggregates at the point of production for approved deposits, ledges, and beds. Do not produce aggregates from non-approved deposits, ledges, or beds. Immediately remove from the stockpile aggregates obtained from non-approved deposits, ledges, or beds.

(3) The Engineer or Inspector will test aggregates for acceptance at the point of usage. Remove and replace, repair, or otherwise correct, at the Contractor's expense, work incorporating aggregates from non-approved sources.

106.6 PLANT INSPECTION

a. When materials are inspected at the point of manufacture, the following apply:

(1) Cooperate with and assist the Engineer or Inspector and make sure the material producer cooperates with and assists the Engineer or Inspector.

(2) The Engineer or Inspector has full right of entry at all times to areas of the plant concerning the manufacture or production of the materials being provided;

(3) Provide and maintain adequate safety measures; and

(4) KDOT may retest materials delivered to the plant that were tested and approved at the source of supply. KDOT may reject materials that do not meet the Contract Documents requirements upon re-testing.

b. The Engineer may accept non-complying, plant-inspected material if all of the following conditions are met:

(1) The Engineer has satisfactory test results of both prior and subsequent material tests using the same source or sources as the non-complying material.

(2) The Engineer finds the incidence and degree of nonconformance with the specification requirements are within reasonable and practical limits.

(3) Demonstrates diligent, exercised material controls consistent with standard industry practices.

(4) The Engineer determines the non-complying material will not adversely affect the value or serviceability of the completed work.

106.7 STORAGE OF MATERIALS

Provide all space required to store stockpiled materials. Locate stored materials to facilitate prompt inspection. Do not use private property to store materials without the owner's or lessee's written approval. Provide copies of such written approval at the Engineer's request. The Engineer may approve portions of the right-of-way for storing materials. Restore all storage sites to their original condition at the Contractor's expense.

Store materials to preserve the materials' quality. The Engineer or Inspector may re-inspect and reject stored materials, even if the Engineer or Inspector previously approved the materials before storage.

106.8 APPROVED MATERIAL SIGNS

a. Provide, install, and maintain "Approved Material" signs at each major material stockpile site that contains both non-KDOT tested and KDOT-approved materials. Sites include the Contractor's or commercial batching areas, plant sites, and major stockpile sites.

b. Install and construct the signs using the material specified below and conforming reasonably to the details shown in **FIGURE 106-1**. Keep the signs clean and in good condition at all times.

(1) Sign Face Details.

- Top Line 4-inch Standard Alphabet Series "B" Legend;
- Second Line 3-inch Standard Alphabet Series "B" Legend;
- I.D. Signs 2-inch Standard Alphabet Series "B" Legend; and
- Plain painted white background with black legend direct applied copy with ¼ inch inset border.

(2) Materials. Manufacture the signs from backing material composed of either metal (14 gauge steel or 0.100 inch thick flat sheet aluminum) or ¾ inch thick exterior type fir plywood and mounted on a suitable post.

306 – CEMENT TREATED BASE

SECTION 306

CEMENT TREATED BASE

Exception: If the PCCP in the contract is not specified as QC/QA, (Bid item Quality Control Testing (CTB) is not included as a bid item) subsections 306.2 (entire subsection), 306.4d. and 306.4g. of this SECTION are not applicable to the contract.

306.1 DESCRIPTION

Design a cement treated base (CTB) mixture meeting the requirements of the Contract Documents. Construct 1 or more courses of the CTB on a prepared roadway as shown in the Contract Documents.

BID ITEMS

Cement Treated Base
Quality Control Testing (CTB)

UNITS

Square Yard
Square Yard

306.2 CONTRACTOR QUALITY CONTROL REQUIREMENTS

a. General. Provide qualified personnel and sufficient equipment complying with the requirements listed in Part V to conduct quality control testing that complies with Appendix B, Sampling and Testing Frequency Chart for Concrete Construction Items for Quality Control/Quality Assurance Projects.

Allow the Engineer access to the Contractor’s laboratory to observe testing procedures, calculations, test documentation and plotting of test results.

Calibrate and correlate the testing equipment with prescribed procedures, and conduct tests in compliance with specified testing procedures as listed in Part V.

Maintain a Quality Manual in the field laboratory showing the calibrations performed on all test equipment and when the next calibration is due for that equipment. As a minimum, follow the calibration/verification interval established in Table 1: Concrete Materials Test Equipment in Section 5.2.7.8-Cement Treated Base: Contractor’s Quality Control Plan (CTB), Part V. See also, Part V Section 5.2.7.8.1-Example of a Laboratory Quality Manual for CTB.

Provide personnel and equipment to conduct quality control testing that complies with the Contract Documents. Provide certified technicians to perform process control testing. Use equipment that complies with, and is calibrated according to the specified test methods.

b. Quality Control Plan (QCP). At the pre-construction conference, submit to the Engineer for approval by the DME, a QCP as outlined in Section 5.2.7-Contractor’s Quality Control Plan, Part V. Follow 5.2.7.8-Cement Treated Base: Contractor’s Quality Control Plan in Part V as a general guideline. Keep a printed copy of the approved QCP in the Contractor’s laboratory and make available to the Engineer when requested.

The Contractor’s laboratory and equipment will be inspected and approved as outlined in Part V, Section 5.2.7-Contractor’s Quality Control Plan.

Include a listing of the names and phone numbers of individuals and alternates responsible for quality control administration and inspection. On the Contractor’s organizational chart, show the specified lines of authority relating both to mix design and quality control operations during production. Post the organizational chart in the Contractor’s test facility.

Provide a quality control organization or private testing firm having personnel certified according to the Policy and Procedures Manual for The Certified Inspection and Testing (CIT) Training Program. The testing for this type of construction will require personnel certified in ACI Concrete Field Testing Technician (CF), Aggregate Field Tester (AGF), Soils Field Tester (SOF) and Nuclear Moisture Density Gauge Tester (NUC) classifications. Only persons certified in the appropriate classifications covering the specific tests required shall perform such testing. Provide a minimum of 1 employee on the project certified in the QC/QA Concrete/Cement Treated Base Specs (QCS) classification.

Only persons certified in the appropriate classifications covering the specific tests required shall perform such testing. At the beginning of the project, provide the Engineer with the list of certified technicians and

306 – CEMENT TREATED BASE

alternates, phone numbers and tests/inspection they will be performing. As personnel changes and certifications may expire, continue to provide the Engineer with an accurate list.

Provide an organizational chart showing the specified lines of authority relating to both mix design and quality control operations during production. Identify the company official acting as liaison with KDOT, and the Certified Technician who will direct inspection and testing. Post the chart in the test facility.

Submit the mix design for the CTB. If an existing mix design is used, provide the mix design number. Include all the elements of the mix design specified in the Contract Documents.

Submit the proposed methods and procedures to control the elements identified as necessary for the quality of the CTB. These elements include, but are not limited to: producing the aggregate, managing the aggregate stockpiles, proportioning the individual materials for the mixture, mixing and transporting the mixture, placing and consolidating the mixture, and finishing and curing the mixture.

c. Required Duties of Certified Technicians. Be available on the project site whenever cement treated base is being produced and being placed on the project site. Perform and utilize quality control tests and other quality control practices to assure that delivered materials and proportioning meet the requirements of the mix designs, including temperature, slump, air content and strength.

Periodically inspect all equipment utilized in transporting, proportioning, mixing, placing, consolidating, finishing and curing to assure it is operating properly and that placement, consolidation, finishing and curing comply with the mix design and other contract requirements.

d. Contractor's Testing Facilities. Describe the testing facility and its accreditation in the QCP.

Locate the testing facility either at the plant site or at the project. Obtain approval of the testing facilities and location from the DME before the commencement of mixture production.

Provide suitable space for the required testing equipment. Also, equip the testing facility with these items for the exclusive use of the testing facility's quality control personnel and the Engineer:

- A telephone with a private line;
- A copying machine; and
- Broadband internet connection (for 1 computer). If the Engineer determines that broadband internet service is not available, provide a fax machine, at no additional cost.

e. Documentation. Include in the QCP procedures, charts and forms to be used to provide the required documentation.

Record and document all test results and calculations. Record all original documentation in a bound field book or other KDOT approved bound record and turn over to KDOT at the end of the project.

At all times, have complete records of all inspections and tests readily available on site for the Engineer. All records documenting the Contractor's quality control inspections and tests become the property of KDOT upon completion of the work.

Indicate the nature and number of observations made, the number and type of deficiencies found, the quantities approved and rejected, and the corrective action taken in the records. Examples of quality control forms and charts are available in Part V, or Contractors may design their own. Documentation procedures are subject to approval by the Engineer before the start of the work and to compliance checks during the progress of the work.

Maintain control charts on an ongoing basis. Plot data according to **SECTION 106**.

Record all test results and calculations on electronic data sheets. Record specific test results on a Daily Quality Summary Sheet to facilitate the computation of moving test averages. Base the moving averages on 4 consecutive test results. Include a description of quality control actions taken (adjustment of aggregate or additive proportions in the mix, moisture adjustments, etc.) in the Daily Quality Summary Sheet.

Provide forms on a computer-acceptable medium, where required. Document batch tickets and gradation data according to KDOT requirements.

Complete testing and charting within 1 working day after sampling.

Keep all quality control charts current. Email or fax the data to the Field Engineer and DME, weekly. Show both individual test results and moving average values. As a minimum, plot the single test values and the 4-test moving average values for gradation of combined aggregates, in-place CTB moisture and dry density, and compressive strength (requires a separate graph for PWL, but no moving average plot).

Complete the charting within 1 working day after the sampling or testing, respective to each type of test.

Make all test results and control charts available to the Engineer at the project site. The Engineer will periodically make compliance checks on the documentation during the progress of the work.

306 – CEMENT TREATED BASE

Submit (email or fax) copies of all failing test results (based on a moving average of 4 tests, if appropriate) and a summary sheet to the Field Engineer on a daily basis.

File all reports, records, charts and diaries developed during the progress of construction activities. Upon completion of the contract, all documentation becomes the property of KDOT.

f. Testing Requirements. In the QCP, identify test methods, procedures and equipment proposed for use. Use standard KDOT test methods and properly calibrated measuring and testing equipment as outlined in Part V. Detail any alternative sampling method, procedure or inspection equipment proposed to be used. Such alternatives are subject to review and approval by the DME.

Take all samples for tests and perform in-place tests at random locations selected according to the Contractor's QC Plan and at the rates specified in the Sampling and Testing Frequency Chart for Cement Treated Base for Quality Control/Quality Assurance Projects in Appendix B, Part V. Retain the latest 10 gradation samples for use by the Engineer.

Retain the second half of the latest 10 gradation samples for use by the Engineer.

g. Mix Design. Design a mixture of aggregate and portland cement or fly ash, or both. If fly ash is used in the mixture, address the set time and strength gain as a function of the ambient temperature. Design the mixture according to the following requirements:

(1) The compressive strength shall be between 650 and 1600 psi. Any test correlating to the maximum value or higher requires scoring or sawing joints in the base that fall within the failing test section (from previous to next passing test sections). Determine compressive strength at 7 days, according to Part V.

(2) Submit a single point gradation for the combined aggregates along with a plus/minus tolerance for each sieve to the Engineer. The plus/minus tolerances shall be used by the Contractor to perform quality control checks and by the Engineer to perform aggregate gradation verification testing. Perform tests on the combined materials.

(3) Submit the mix batch weights in an acceptable manner to the DME. Address the initial set times (specified in AASHTO T 154) and placement times (with regards to the set times) in the proposed mix design.

(4) Submit laboratory compressive strength test results on a minimum of 1 set of 3 plugs, produced from the proposed mix design and utilizing the actual materials proposed for use on the contract.

(5) Submit the test results 2 weeks prior to the anticipated date for using the design on the contract. The Engineer will review the design within 5 working days of receipt. The Engineer may perform any testing necessary to verify the adequacy of the Contractor's design. If the Engineer calls for verification tests, supply the Engineer with the necessary materials to enable the Engineer to test the mix properties within 5 working days of notification.

(6) Submit any proposed changes to the approved mix design to the DME for approval before implementing the proposed changes.

h. Corrective Action. In the QCP, identify procedures for notifying the Engineer when corrective measures must be implemented, and for halting production.

Notify the Engineer when the moving average test result trend line for any property approaches the specification limits. Cease operations when 2 consecutive moving average points fall outside the specification limits, or 2 consecutive single compressive strength tests exceed the specification limits. Ceasing operations is the Contractor's responsibility. Quality control tests for this determination include aggregate gradation, compliance with the mix design band and in-place density of CTB.

Failure to cease operations for the conditions cited above will subject all subsequent material to rejection, or acceptance at a reduced price, as determined by the Engineer.

The Engineer may examine materials represented by individual test results, which lie beyond the Contractor's normal quality control testing variation. The investigation may be based on either Contractor or KDOT test results. The information from additional testing (including testing of in-place pavement) may be used to define unacceptable work according to **SECTION 105**. The Engineer will apply appropriate price reductions or initiate corrective action.

If a dispute exists between the Engineer and Contractor about the validity of any test results other than compressive strengths or thickness determination, the KDOT District Materials Laboratory or MRC will perform referee testing. If one of the disputed KDOT test results was generated at the MRC, then an independent laboratory agreeable to both parties will be selected. The AASHTO Accreditation Program shall have approved the selected laboratory for the appropriate test procedure. If referee testing indicates that KDOT test results are correct, the Contractor is responsible for the cost of additional testing, including referee testing performed at the MRC. If the

306 – CEMENT TREATED BASE

referee testing indicates that the Contractor test results are correct, KDOT is responsible for the cost of additional testing.

i. Non-Conforming Materials. In the QCP, specifically address how non-conforming materials will be controlled and identified.

Establish and maintain an effective and positive system for controlling non-conforming material, including procedures for its identification, isolation and disposition. Reclaim or rework non-conforming materials according to procedures acceptable to the Engineer.

Identify all non-conforming materials and products to prevent use, shipment and intermingling with conforming materials and products. Provide holding areas, mutually agreeable to the Engineer and Contractor.

The Engineer will determine if reclaiming or reworking of non-conforming materials is allowed.

306.3 MATERIALS

Provide materials that comply with the applicable requirements.

Concrete Admixtures & Curing Material	DIVISION 1400
Portland Cement and Fly Ash	DIVISION 2000
Water for CTB	DIVISION 2400
Aggregates for CTB	DIVISION 1100

306.4 CONSTRUCTION REQUIREMENTS

a. Preparation and Maintenance of the Subgrade. Before placing any CTB material on any section, complete the ditches and drains along that section to effectively drain the highway. Use automatic grade control equipment to trim the surface of the subgrade to the line, grade and cross-section as shown in the Contract Documents. Maintain the subgrade to the as-constructed condition under other contract bid items, repairing any encountered defects to the specifications of the previous bid items. Maintain the subgrade surface to readily drain at all times. Protect the subgrade from damage when handling materials, tools and equipment. Do not store or stockpile materials on the subgrade. Do not place material or lay CTB on a frozen or muddy subgrade.

Lightly spray the subgrade with water to obtain a thoroughly moistened condition before the CTB is placed. Do not puddle water on the grade.

Do not place CTB on frozen subgrade. Do not deposit any material until the subgrade or base has been checked and approved by the Engineer.

b. Mixing the Materials. Do not place CTB on the project until the Engineer has reviewed and approved the submitted mix design.

Plant mix the aggregate, cementing agent and water according to the approved mix design.

Control the charge in a batch mixer, or the rate of feed to a continuous mixer (pugmill), to allow complete mixing of all the materials. Mix the materials to produce a homogeneous mixture. Do not use frozen aggregate.

Take all compressive strength samples at the plant site. Compact the samples prior to the CTB reaching its initial set.

c. Spreading and Compacting the CTB. The maximum compacted thickness of a single lift is 6 inches. If the thickness is greater than 6 inches, spread and compact the subgrade in multiple lifts of equal thickness with a maximum lift thickness of 6 inches. If the base is spread in multiple lifts, offset the longitudinal joints by at least 6 inches.

If multiple lifts are placed, keep the surface of each lift moist until the succeeding lift is spread. Cover the exposed lower lift with the final lift the same day the lower lift is placed.

Compact each lift of CTB to a minimum of 95% of the standard density.

Compact the CTB within 2 hours from the time the water and cementing agent is added to the aggregate, or before the mixture reaches the initial set, whichever is the shorter timeframe.

d. Compaction Determination. Determine dry density and moisture content according to Part V.

306 – CEMENT TREATED BASE

If the mix is stiff (can be slip-formed), determine the standard density by averaging the 3 most recent field molded densities using plant mixed base material. Compact one standard mold (using plant mixed material with the proper moisture content) for each day's operation as specified in KT-37.

If the mix is fluid (requires forming), determine the Standard Dry Density by averaging the 3 most recent consolidated unit weight test results (KT-20). It will be necessary to convert the unit weight (wet density) into a standard dry density which also requires the percent of moisture (KT-11 (4)) to be known. Use Equation 1 to determine the standard dry density.

$$\text{Equation 1: Standard Dry Density} = \frac{\text{Wet Density}}{(1 + [\% \text{Moisture} / 100])}$$

Determine the density of the CTB within 1 day of the compaction operations. The Engineer may verify the Contractor's density test results by conducting density tests at random. If the comparison is not favorable, the DME will investigate to determine the cause and may suspend production until corrective action is taken.

e. Trimming and Finishing the CTB. Trim and recompact the CTB within 2½ hours of the time the water and cementing agent is added to the aggregate.

Trim and compact the CTB to the grades, lines and typical cross sections shown in the Contract Documents. Dress the edge slopes and joints between sections.

Use automatic grade control equipment to trim the surface of the CTB to line grade and cross section.

Keep the surface of the CTB moist during all finishing operations.

Perform the finishing and compacting operations to produce a smooth, dense surface, free of surface compaction planes, cracks, ridges or loose material.

If required, lightly scarify the surface of the CTB to loosen any imprints left by the trimming and compacting equipment. Recompact the surface of the CTB.

At the end of each day's operations, construct a straight transverse construction joint by cutting back into the completed work to form a vertical face. Place a protective covering of earth on the newly constructed CTB a distance back of the joint for turning of equipment used on the following day's work.

Upon satisfactory performance, the Engineer may approve the use of equipment that combines the placing, compacting and finishing operations.

f. Protection and Curing. Keep the surface of the CTB moist until the curing material is applied. Apply the curing material immediately after completing the trimming and finishing. Protect the CTB against the loss of moisture for a curing period of 7 days (unless the Contractor's mix design test results justify a different curing period). Protect the CTB against freezing during the curing period.

Apply a wax-based liquid membrane-forming compound for the curing material. The minimum application rate for wax-based liquid membrane-forming compound is 0.12 gallons per square yard. Use an enclosed spray system that minimizes wind influence and obtains the proper application rate. Keep all traffic and construction equipment off the CTB. The only exception is the equipment used to apply the curing material. Cover the surface and edges of the CTB with a complete, uniform coverage. Use a hand sprayer in inaccessible areas.

If the wax-based liquid membrane-forming compound will be in place for more than 30 days, reapply a single coat at the single application rate within 7 days of placing the pavement.

At locations where it is necessary to carry traffic across the CTB, place a layer (8 inches or greater, compacted depth) of stable earth (sand-clay) over the CTB.

The Contractor may place portland cement concrete pavement (PCCP) on the CTB after a minimum of 24 hours, provided all traffic and construction equipment is kept off the CTB.

The Contractor assumes the risk of 7-day compressive strength requirements when PCCP is placed early.

To promote cracking through the full depth of the base, score or cut the finished CTB surface to coincide with the pavement joint locations, in a parallel manner and within 1 foot:

- if the 7-day compressive strength exceeds 1600 psi. (Note: This does not apply if the CTB has developed cracks at regular intervals prior to placing the PCCP.)
- if the Contractor opts to place the PCCP over the CTB before the 7-day compressive strength is determined. The Engineer may waive this requirement when the Contractor's control charts for CTB shows a history that the 7-day compressive strength is below 1600 psi.

306 – CEMENT TREATED BASE

g. Compressive Strength Determination. Using random numbers, select and obtain sampled material at the plant. Make and cure compression test specimens to represent each subplot. Make and cure compression test specimens, and determine the 7-day compressive strength of the CTB according to Part V. Sulfur cap compression test specimens in accordance with AASHTO T 231. When additional test specimens are taken for early determination of the compressive strength, the specimens are for information only. Perform the 7-day compressive strength testing. Maintain records of all sampling and testing. The Engineer will witness all compressive strength tests and initial the Contractor's documentation.

A percent within limits (*PWL*) analysis shall be made on a lot-by-lot basis and shall be based on Contractor quality control test results on all quality control samples representing the lot of the completed CTB. The *PWL* result shall be determined as specified under Computation of Pay Factor. Compute the pay adjustment as shown in Equation 2. It shall be based on the compressive strength values within each lot and the lower specification limits (*LSL*).

KDOT will use a spreadsheet program to calculate pay adjustments for compressive strength and to compare the Contractor's QC and KDOT's verification test results. If the comparison fails, KDOT's value will be used to calculate the pay adjustment for that lot. The lot comparison is based on KDOT's verification result falling within the Contractor's mean, plus or minus 2 times the Contractor's sample standard deviation. When the Contractor's sample standard deviation is less than 260 psi, then 260 psi shall be used for the sample standard deviation during lot comparison with KDOT's value. When there are 3 or more tests in a lot and when the lot comparison between Contractor and KDOT tests pass, the Contractor's actual standard deviation will be used to calculate the compressive strength pay factor. When requested, KDOT will provide a copy of this program to the Contractor. It is the Contractor's responsibility to obtain the software required to run this program.

Values computed using equations referenced in this specification may vary slightly from the spreadsheet values due to the rounding of numbers. In such cases, the numbers computed by the spreadsheet shall take precedence.

A typical lot is defined as a normal day's placement. At the beginning of the project, estimate the quantity to be placed during a normal day and submit to the Engineer for approval. Once approved, break the quantity into 4 equal parts (each part represents a subplot). Determine a random location for sampling within each subplot. When the total quantity for the day deviates from expectations, adjust the number of sublots based on **TABLE 306-1**.

TABLE 306-1: SUBLLOT BREAKDOWN OF A NORMAL DAY'S PRODUCTION	
Number of Sublots	% of Daily Quantity
4	75-115
3	50-74
2	25-49
1	1-24

Adjust the quantity of the last subplot to accommodate any minor changes in production, and adjust the random location for sampling based on the size of the subplot. When there is only 1 test in a lot, the pay factor will be automatically calculated by the KDOT spreadsheet using a sample standard deviation of 260 psi and n of 3. When there are 2 tests in a lot, the pay factor will be calculated by the KDOT spreadsheet using a spreadsheet calculated standard deviation and n of 3. When there are 3 or 4 tests, the lot stands on its own. Regardless of the number of Contractor tests in a lot, the lot comparison between Contractor and KDOT tests will apply. When the quantity exceeds 115% of the normal daily quantity, increase the number of sublots and restrict the 4th subplot to a maximum of 100% of the established normal daily quantity. Each subplot added may have a maximum of 25% of the normal daily quantity.

Compute the sample standard deviation as shown in Section 5.2.1-Statistics, Part V.

Calculate the Compressive Strength Quality Indices (Q_L) for each lot as shown in Section 5.2.1-Statistics, Part V. Use the following definitions, and round to the nearest hundredth.

Where: \bar{X} is the average measured compressive strength of all QC samples representing a lot, rounded to 1.0 psi.

LSL is the lower specification limit for compressive strength, defined as 650 psi.

S is the sample standard deviation of the compressive strength of all QC samples representing a lot, rounded to 0.1 psi.

306 – CEMENT TREATED BASE

Determination of the percent within limits (*PWL*) values. Use the computed *Q* value to determine the compressive strength percent within limits value (*PWL_C*) by locating the *Q_L* values in the left column of the *PWL* Table in Section 5.2.1-Statistics, Part V. Select the appropriate *PWL_C* by moving across the selected *Q_L* to the column representing the number of samples in the lot.

When the computed *Q_L* is a negative value (\bar{X} lies below the *LSL*), the Engineer will determine if the material in the lot may remain in place. If the material is left in place, and there were no individual plugs found to be less than 600 psi, then 50.00 is assigned as the *PWL* value. For results exceeding these limits and permitted to remain in place, use the calculated *PWL* value.

When the computed *Q_L* is greater than the largest *Q_L* value shown in the table, a value of 100.00 is assigned as the *PWL* value for the designated *PWL_C*.

Computation of Cement Treated Base Compressive Strength Pay Adjustment. Compute the pay factor for compressive strength using Equation 2 and round to nearest thousandth (0.001). Multiply the pay factor times the square yards, times \$5.00 per square yard to determine the pay adjustment.

$$\text{Equation 2: } P = \frac{(PWL_C \times 0.15)}{100} - 0.135$$

Cement Treated Base Compressive Strength Pay Factor (Failing Comparison Test). When the comparison between Contractor and KDOT tests fails, use KDOT test results to calculate the compressive strength pay factor for the lot. Follow the procedures as stated above to determine the pay factor or disposition of the lot. Use the following values to determine *Q_L*: \bar{X} of KDOT's test result for the lot, *S* of 260 psi, *LSL* of 650 psi. When selecting the *PWL_C* value from the *PWL* in TABLE 2, use *n* of 4.

h. Weather Limitations. Do not place material if the CTB will be exposed to ambient air temperatures below 32°F during the first 7 days of cure. (See subsections 306.4b., c. and f.). Remove and replace all CTB that is permitted to freeze within the first 24 hours, whether frozen on the surface or full depth. When materials are exposed to freezing ambient air temperatures after the first 24 hours but before the 7 day cure period is complete, demonstrate that the 7 day design strength has been achieved. Failure to demonstrate the 7 day design strength has been achieved shall require removal and replacement at Contractor's expense.

As directed by the Engineer and at the Contractor's expense, repair or replace cured materials exposed to ambient air temperatures below freezing or repeated freeze/thaw cycles that result in loosening or fluffing of the surface.

A lift of pavement placed prior to exposure to freezing ambient air temperatures constitutes curing of the CTB.

Do not place material on frozen subgrade. Mixing and placing may proceed when the ambient air temperature is 40°F and rising, and discontinue when the ambient air temperatures reaches 45°F and falling.

306.5 MEASUREMENT AND PAYMENT

The Engineer will measure the CTB and quality control testing of CTB by the square yard. Material placed beyond the neat lines indicated in the Contract Documents is not measured for payment unless authorized by the Engineer.

Payment for "Cement Treated Base" and "Quality Control Testing (CTB)" at the contract unit prices is full compensation for the specified work.

No adjustment of the contract unit price for "Quality Control Testing (CTB)" is made for overruns or underruns in the contract quantity.

If the PCCP in the contract is specified as QC/QA, (Quality Control Testing (CTB) is included as a bid item), compressive strength pay adjustments will apply under the bid item "Cement Treated Base Compressive Strength Pay Adjustment", and will be shown as an added item to the contract.

**KANSAS DEPARTMENT OF TRANSPORTATION
SPECIAL PROVISION TO THE
STANDARD SPECIFICATIONS, 2015 EDITION**

Delete SECTION 401 and replace with the following:

SECTION 401

GENERAL CONCRETE

401.1 DESCRIPTION

Provide the grades of concrete specified in the Contract Documents.
See SECTION 402 for specific requirements for Structural Concrete.
See SECTION 403 for specific requirements for On Grade Concrete.
See SECTION 404 for specific requirements for Prestressed Concrete.

401.2 MATERIALS

Provide materials that comply with the applicable requirements.

Aggregate	DIVISION 1100
Admixtures and Plasticizers	DIVISION 1400
Grade 2 Calcium Chloride.....	DIVISION 1700
Cement, Fly Ash, Silica Fume, Slag Cement and Blended Supplemental Cementitious.....	DIVISION 2000
Water	DIVISION 2400

401.3 CONCRETE MIX DESIGN

a. General. Design the concrete mixes specified in the Contract Documents.

Do not place any concrete on the project until the Engineer approves the concrete mix designs. Once the Engineer approves the concrete mix design, do not make changes without the Engineer's approval.

Take full responsibility for the actual proportions of the concrete mix, even if the Engineer assists in the design of the concrete mix.

Provide aggregate gradations that comply with **DIVISION 1100** and Contract Documents.

Admixture dosage rate requirements for mix design approval and field production are provided in **subsection 401.3k**.

If desired, contact the DME for available information to help determine approximate proportions to produce concrete having the required characteristics on the project.

Submit all concrete mix designs to the Engineer for review and approval. Submit completed volumetric mix designs on KDOT Form No. 694 and all required attachments at least 60 days prior to placement of concrete on the project. The Engineer will provide an initial review of the design within 5 business days following submittal.

Include the following information:

(1) Test data from KT-73 tested at 28 days, KT-79 tested at 28 days or AASHTO T-277 tested at 56 days. Provide test results on a minimum of 1 set of 3 cylinders for each mix, tested at the highest water to cementitious material ratio that meets **subsection 401.3h**. Submit accelerated cure procedures for the Engineer's approval.

(2) Test data from ASTM C 1567 for blended cements meeting **subsection 401.3j**. for all concrete utilizing all actual materials proposed for use on the project at designated percentages.

(3) Single point grading for the combined aggregates along with a plus/minus tolerance for each sieve. Use plus/minus tolerances to perform quality control checks and by the Engineer to perform aggregate grading verification testing. The tests may be performed on the combined materials or on individual aggregates, and then theoretically combined to determine compliance.

(4) Laboratory 28-day compressive strength test results on a minimum of 1 set of 3 cylinders produced from the mix design with the highest water to cementitious ratio for the project, utilizing all actual materials

proposed for use on the project at designated percentages. The average compressive strength shall exceed the strength requirements for the Grade specified in the Contract Documents as determined by **subsection 401.3b**. Perform compressive strength tests according to KT-76.

(5) Historical mix production data for the plant producing concrete for the project to substantiate the standard deviation selected for use in **subsection 401.3b.**, if applicable.

(6) Necessary materials to enable the Engineer to test the mix properties, if applicable.

(7) Batching sequence. Consider the location of the concrete plant in relation to the job site, and identify when and at what location the water reducer or plasticizer is added to the concrete mixture.

Submit complete mix design data including proportions and sources of all mix ingredients, and the results of strength and permeability tests representing the mixes proposed for use. The data may come from previous KDOT project records or a laboratory regularly inspected by Cement and Concrete Reference Laboratory (CCRL). Data from other sources will only be accepted if testing was conducted or witnessed by personnel certified in Hardened Concrete Properties (HCP) according to the Policy and Procedures Manual for The Certified Inspection and Testing (CIT) Training Program.

After initial review, the Engineer will perform any testing necessary to verify the design. This may include a 3-cubic yard test batch at the producing plant. Do not make changes to the Approved Concrete Mix Design without the Engineer's approval. Limited adjustments may be made to admixture dosages and aggregate proportions in accordance with **subsection 401.3i** and **subsection 403.4e**. These adjustments must be recorded and submitted to the Engineer.

Mix designs will remain approved when verification testing for strength and permeability conducted within the last 12 months indicate continued compliance with the specifications and percentages of constituents including aggregate and cementitious materials and product, type and supplier of admixtures remain the same. Test results on the same mix from other sources are acceptable.

Improvements in concrete strength, workability, durability and permeability are possible if the combined aggregate grading is optimized. Procedures found in ACI 302.1 or other mix design techniques, approved by the Engineer, are acceptable in optimizing the mix design.

Delay the commencement of tests for temperature, slump, and air content and molding of field cylinders from 4 to 4½ minutes after the sample has been taken from a continuous mixer. If a batch type mixer is used, take the tests at the point of placement and begin testing immediately.

b. Required Compressive Strength for Concrete Mix Design. The required compressive strength for mix design approval shall be based on previous data from similar mix designs or according to **subsection 401.1b.(2)**.

(1) Concrete Mix Design Based on Previous Data. Provide concrete mix designs based on previous 28-day compressive strength test data from similar concrete mixtures. Similar mixtures are within 1000 psi of the specified 28-day compressive strength, and are produced with the same type and sources of cementitious materials, admixtures and aggregates.

Consider sand sources the same, provided they are not more than 25 miles apart on the same river and no tributaries enter the river between the 2 points. Consider crushed locations similar if they are mined in one continuous operation, and there is no significant change in geology. Mixes that have changes of more than 10% in proportions of cementitious materials, aggregates or water content are not considered similar.

Air entrained mixes are not considered similar to non-air entrained mixes.

Mixes tested with admixtures are not the same as mixes tested without those admixtures.

Test data should represent at least 30 separate batches of the mix. One set of data is the average of at least 2 cylinders from the batch. The data shall represent a minimum of 45 days of production within the past 12 months.

Do not include data over 1 year old. When fewer than 30 data sets are available, the standard deviation of the data must be corrected to compensate for the fewer data points.

Provide a 4000 psi concrete with a f'_{cr} greater than or equal to 5200 psi. Otherwise provide a concrete mix design that will permit no more than 5% of the 28-day compressive strength tests to fall below the specified 28-day compressive strength (f'_c) based on equation A, and no more than 1% of the 28-day compressive strength tests to fall below the specified 28-day compressive strength (f'_c) by more than 500 psi based on equation B.

Equation A:
$$f'_{cr} = f'_c + 1.62 * k * s$$

Equation B:
$$f'_{cr} = (f'_c - 500) + 2.24 * k * s$$

If a truck mixer or truck agitator is used to transport concrete that was completely mixed in a stationary central mixer, agitate the concrete while transporting at the agitating speed specified by the manufacturer of the equipment (shown on the manufacturer's plate on the equipment). Do not exceed 200 total revolutions (additional re-mixing and agitating).

Provide a batch slip including batch weights of every constituent of the concrete and time for each batch of concrete delivered at the work site, issued at the batching plant that bears the time of charging of the mixer drum with cementitious materials and aggregates. Include quantities, type, product name and manufacturer of all admixtures on the batch ticket.

On paving projects and other high volume work, the Engineer will evaluate the haul time, and whether tickets will be collected for every load. Thereafter, random checks of the loads will be made. Maintain all batch tickets when not collected.

When non-agitating equipment is used for transportation of concrete, place within 30 minutes of adding the cement to the water. Provide approved covers for protection against the weather when required by the Engineer.

When agitating equipment is used for transportation of the concrete, place concrete within the time and temperature conditions shown in **TABLE 401-5**.

TABLE 401-5: AMBIENT AIR TEMPERATURE AND AGITATED CONCRETE PLACEMENT TIME		
T = Ambient Air Temperature at Time of Batching (°F)	Time limit agitated concrete must be placed within, after the addition of cement to water (hours)	Admixtures
T < 75	1 ½	All Cases
75 ≤ T < 90	1	None
75 ≤ T < 90	1 ½	Set Retarder
T_c = Concrete Temperature at time of placement (°F)	Time limit agitated concrete must be placed within, after the addition of cement to water (hours)	Admixtures
90 ≤ T _c *	¾	All Cases
Other conditions contributing to quick stiffening of concrete	¾	All Cases

Do not use concrete that has developed its initial set. Regardless of the speed of delivery and placement, the Engineer will suspend the concreting operations until corrective measures are taken, if there is evidence that the concrete cannot be adequately consolidated.

Weather conditions and the use of admixtures can affect the set times for the concrete. Do not use the time limits and total revolutions as the sole criterion for rejection of concrete. Exceed the time limits and total revolutions only after demonstrating that the properties of the concrete can be improved. Evaluation of the consistency and workability should be taken into consideration. Reject concrete that cannot be adequately consolidated.

Adding water to concrete after the initial mixing is prohibited, with this exception:

If the concrete is delivered to the work site in a truck mixer, the Engineer will allow water (up to 2 gallons per cubic yard) be withheld from the mixture at the batch site, and if needed, added at the work site to adjust the slump to the specified requirements. Determine the need for additional water as soon as the load arrives at the construction site. Use a calibrated water-measuring device to add the water, and add the water to the entire load. Do not add more water than was withheld at the batch site. After the additional water is added, turn the drum or blades an additional 20 to 30 revolutions at mixing speed. The Engineer will supervise the adding of water to the load, and will allow this procedure only once per load. Conduct all testing for acceptance and produce any required cylinders after all water or admixtures have been added.

Do not add water at the work site if the slump is within the designated slump tolerance, even if water was withheld.

Do not add water at the work site if the percent air is above 8%, regardless of the slump, even if water was withheld.

Do not withhold and add water if plasticizer is added to the concrete mixture at the batch site.

If at any time during the placement of concrete it is determined that redosing with water is adversely affecting the properties of the concrete, the concrete will be rejected and the Engineer will suspend the practice.

b. Placement Limitations.

(1) Placing Concrete at Night. Do not mix, place or finish concrete without sufficient natural light, unless an adequate, artificial lighting system approved by the Engineer is provided.

(2) Placing Concrete in Cold Weather. Unless authorized by the Engineer, discontinue mixing and concreting operations when the descending ambient air temperature reaches 40°F. Do not begin concreting operations until an ascending ambient air temperature reaches 35°F and is expected to exceed 40°F.

If the Engineer permits placing concrete during cold weather, aggregates may be heated by either steam or dry heat system before placing them in the mixer. Use an apparatus that heats the mass uniformly and is so arranged as to preclude the possible occurrence of overheated areas which might injure the materials. Do not heat aggregates directly by gas or oil flame or on sheet metal over fire. Aggregates that are heated in bins, by steam-coil or water-coil heating, or by other methods not detrimental to the aggregates may be used. The use of live steam on or through binned aggregates is prohibited. Unless otherwise authorized, maintain the temperature of the mixed concrete between 50 to 90°F at the time of placing. Do not, under any circumstances, continue concrete operations if the ambient air temperature is less than 20°F.

If the ambient air temperature is 35°F or less at the time the concrete is placed, the Engineer may require that the water and the aggregates be heated to between 70 and 150°F.

Do not place concrete on frozen subgrade or use frozen aggregates in the concrete.

Make adjustments for potential longer set time and slower strength gain for concrete with SCMs. Adjust minimum time requirements as stated in **SECTION 710** for concrete used in structures. For concrete paving, be aware of the effect that the use of SCMs (except silica fume) may have on the statistics and moving averages.

401.9 INSPECTION AND TESTING

Unless otherwise designated in the Contract Documents or by the Engineer, obtain samples of fresh concrete for the determination of slump, weight per cubic yard and percent of air from the final point of placement.

The Engineer will cast, store and test strength and permeability test specimens in sets of 3.

KDOT will conduct the sampling and test the samples according to **DIVISION 2500** and the Sampling and Testing Frequency Chart in Part V. For QC/QA contracts, establish testing intervals within the specified minimum frequency.

The Engineer will reject concrete that does not comply with specified requirements.

The Engineer will permit occasional deviations below the specified cementitious content, if it is due to the air content of the concrete exceeding the designated air content, but only up to the maximum tolerance in the air content.

Continuous operation below the specified cementitious content for any reason is prohibited.

As the work progresses, the Engineer reserves the right to require the Contractor to change the proportions if conditions warrant such changes to produce a satisfactory mix. Any such changes may be made within the limits of the specifications at no additional compensation to the Contractor.

**KANSAS DEPARTMENT OF TRANSPORTATION
SPECIAL PROVISION TO THE
STANDARD SPECIFICATIONS, 2015 EDITION**

Delete SECTION 403 and replace with the following:

SECTION 403

ON GRADE CONCRETE

403.1 DESCRIPTION

Provide the grades of concrete specified in the Contract Documents.

This specification is specific to On Grade Concrete. See **SECTION 401** for general concrete requirements.

403.2 MATERIALS

Provide materials that comply with the applicable requirements.

General Concrete.....	SECTION 401
Aggregate	DIVISION 1100
Admixtures and Plasticizers	DIVISION 1400
Grade 2 Calcium Chloride.....	DIVISION 1700
Admixtures and Plasticizers	DIVISION 1400
Cement, Fly Ash, Silica Fume, Slag Cement and Blended Supplemental Cementitious	DIVISION 2000
Water	DIVISION 2400

403.3 CONCRETE MIX DESIGN

a. General. Design the concrete mixes for on grade concrete as specified in the Contract Documents.

b. Concrete Mix Design. Use procedures outlined in **SECTION 401**.

c. Portland Cement and Blended Hydraulic Cement and Supplemental Cementitious Materials.

Unless specified otherwise in the Contract Documents, select the type of portland cement, blended hydraulic cement and supplemental cementitious materials as specified in **SECTION 401**.

d. On Grade Concrete Specific Requirements. Use Optimized, Air-Entrained Concrete. Provide the Engineer written notification of mix design selection prior to the pre-construction conference.

(1) Design air-entrained concrete for pavement meeting **TABLE 403-1**.

(2) Design air-entrained concrete for shoulders meeting **TABLE 403-2**.

(3) Design air-entrained concrete for other uses with a maximum water to cementitious ratio of 0.45 and a minimum cementitious content of 480 lbs per cubic yard.

(4) For projects that are not QC/QA paving projects, verify the mix design in the field by performing compressive strength tests on cylinders made from samples taken from concrete produced at the project site before or during the first day that concrete pavement is placed on the project. If the compressive strength tests indicate noncompliance with minimum design values, suspend paving operations and submit a new mix design for approval.

(5) Control air content for PCCP by **subsection 403.4**.

(6) The amount of cementitious material listed in **TABLES 403-1** and **403-2** is the designated minimum for concrete pavement and shoulders respectively. It may be necessary to add additional cementitious material or otherwise adjust the mix proportions as permitted by the specifications to provide a mix design that complies with the compressive strength and permeability requirements.

(7) Maximum limit of lb. of water per lb. of cementitious material includes free water in aggregates, but excludes water of absorption of the aggregates.

- (8) Concrete permeability requirements according to **TABLES 403-1** and **403-2**.
 (9) Permeability requirements do not apply for concrete patching material used in **SECTION 833** when existing pavement to be patched is more than 10 years old.
 (10) ASTM C1567 may be required if supplementary cementitious materials (SCMs) other than silica fume are utilized. See **subsection 401.3j**. for requirements.

TABLE 403-1: AIR-ENTRAINED CONCRETE FOR PAVEMENT						
lb. of Cementitious per yd³ of Concrete, minimum	lb. of Water per lb. of Cementitious, maximum	Percent of Air by Volume	28-Day Comp Strength, psi minimum	Volume of Permeable Voids, maximum	Surface Resistivity, minimum	Rapid Chloride Permeability, maximum
517	0.45	See subsection 403.3e.	4000	12.5%	9.0 kΩ-cm	3000 Coulombs

TABLE 403-2: AIR-ENTRAINED CONCRETE FOR SHOULDERS					
lb. of Cementitious per yd³ of Concrete, minimum	lb. of Water per lb. of Cementitious, maximum	Percent of Air by Volume	Volume of Permeable Voids, maximum	Surface Resistivity, minimum	Rapid Chloride Permeability, maximum
480	0.45	See subsection 403.3e.	12.5%	9.0 kΩ-cm	3000 Coulombs

(11) Concrete for shoulders using the same aggregates, gradations, and water to cementitious ratio as the mainline pavement concrete on the same project will be approved without testing for Volume of Permeable Voids, Surface Resistivity or Rapid Chloride Permeability.

e. Design Air Content. Provide a minimum air content that complies with these 2 criteria:

- a minimum volume of 5.0% or the volume determined using Equation C, whichever is greater, as measured behind the paver, and
- a maximum AVA spacing factor of 0.0100 inch behind the paver.

For a typical PCCP, design the mix at the minimum air content plus 0.5%.

The target air content is the air content that meets both criteria above.

If the AVA spacing factor exceeds 0.0100 inch, use Equation C to determine the target air content required to produce an acceptable spacing factor.

Equation C: Min. % air content at 0.0100 inch = % air measured + (measured AVA spacing factor – 0.0100)/0.0010.

Mixes with Laboratory or Field Prequalification AVA spacing factors greater than 0.0100 inch will not be approved.

When AVA spacing factors exceed 0.0100 inch take immediate steps to reduce the spacing factor. The Field Engineer will conduct an investigation using the following steps. If any one of the steps 1 through 9 corrects the problem, the Field Engineer will stop the investigation. The steps may be completed in combination and/or out of order. For example some may want to conduct steps 5 or 6 before some of the other steps.

1. If the failing sample came from behind the paver, the Engineer will take the following steps. Obtain an AVA sample from a unit weight bucket of concrete obtained from grade in front of the paver. Also, measure the total air content in the concrete on the grade in front of the paver. Obtain AVA and total air samples from behind

the paver. Determine the loss of air and spacing factor due to the paving operation. Adjust for air loss due to paving.

2. Verify calibration of the AVA.
3. Change the location of the AVA during testing.
4. Call in the Research Unit or another AVA machine for comparison testing.
5. Check the mix design for compliance with **SECTION 401**.
6. Check all of the gradations.
7. Check the total air content vs. target air content.
8. Check for Contractor compliance with admixture supplier's recommendations on dosage rates and order of introduction of the chemicals into the mix.
9. Check for material compatibility by using different admixtures or sources of admixtures.

Refer to the "11 Strategies to Improve the Air-Void Spacing Factor" in **APPENDIX A**.

If the problem is not corrected, the Field Engineer will take the following steps:

Obtain 2 cores from any area with an AVA spacing factor >0.0125 inches and send to Materials Research Center for hardened air evaluation.

- If the AVA spacing factor > 0.0125 inches and the average hardened air spacing factor is > 0.0080 inches, then suspend paving and submit new mix design.
- If the AVA spacing factor > 0.0125 inches and the average hardened air spacing factor < 0.0080 inches, then accept PCCP.

Take immediate steps to increase the air content whenever the air content behind the paver falls below 5.0%. Suspend paving operations when 2 consecutive air contents behind the paver fall below 5.0%. Suspend paving operation and remove and replace the represented concrete when air content behind the paver falls below 4.0%.

Air Void Spacing Factor does not apply to concrete used in **SECTION 833** when existing pavement to be patched is more than 10 years old.

The maximum air content is 10%. Take immediate steps to reduce the air content whenever the air content exceeds 8%.

f. Slump.

(1) Maximum design slump for slip form On Grade Concrete is 2 ½ inches. Do not designate a slump in excess of 5 inches for all other On Grade Concrete.

(2) For all other On Grade Concrete placement, designate a slump that is required for satisfactory placement of the concrete application. Reject concrete with a slump that limits the workability or placement of the concrete.

(3) If the designated slump is 3 inches or less, the tolerance is ±3/4 inch, or limited by the maximum allowable slump for the individual type of construction.

(4) If the designated slump is greater than 3 inches the tolerance is ±25% of the designated slump.

403.4 AIR-ENTRAINED ON GRADE CONCRETE

a. Air Content for PCCP. Provide an air content that complies with **subsection 401.3e**.

Using fresh concrete, the Engineer will determine the air void spacing factor using the AVA according to the manufacturer's requirements. Prequalify mixtures by either the laboratory option or the field option. Contact the Engineer to arrange testing by the AVA. Additional AVA testing will be required if the concrete plant is changed during the course of the project.

b. Laboratory Prequalification. Prepare a trial mix using a drum-type mixer according to AASHTO T 126 using all of the materials in the proportions, except the air entraining agent, contemplated for use in the field. Laboratory mixes require more air entraining agent than is needed in the field.

The Engineer will perform the following: Consolidate a sample in the unit weight bucket by vibration according to KT-20. Obtain 3 samples from the unit weight bucket for testing by the AVA. Valid results must have a minimum of 2 spacing factor readings within a range of 0.0025 inch. Test the third sample if the first 2 do not meet these criteria. Determine the air content of the trial mix by KT-19 (Volumetric Method) or KT-18 (Pressure

Method) calibrated to yield the same result. Calculate a target percent air content at a maximum air void spacing factor of 0.01 inch using the equation in **subsection 403.3e.**, when applicable.

c. Field Prequalification. Produce a trial batch at a minimum air temperature of 60°F using the batch plant and project materials.

The Engineer will perform the following: Test for air content by the procedure specified under laboratory prequalification. Correlate this air content to the average of at least 2 valid AVA test results. Valid AVA results have a maximum range of 0.0025 inch.

When necessary, calculate a target percent air content at a maximum AVA spacing factor of 0.0100 inch, using the Equation C in **subsection 403.3e.**

d. Field Verification. Coordinate with the Engineer so production samples may be obtained behind the paver to establish the target air content on the first paving day. Produce concrete using the same materials and proportions that were used in the prequalification mixture. Adjustments may be approved in the dosage of air entraining agent. AVA samples will be taken both in the path of a vibrator and the gap between vibrators.

Perform the test for air content at the delivery site of the concrete KT-19 (Roll-a-meter) or KT-18 (pressure meter), calibrated to yield the same result.

e. Control of the Air Content During Paving Operations. Maintain an air content behind the paver as determined by KT-19 or KT-18, which meets **subsection 403.3e.** Maintain all production parameters established during field verification. The dosage of air-entraining agent may be varied to control the air content. With AVA testing, 5% adjustments will be permitted to the aggregate proportions, as well as any adjustment to the water reducer in accordance with **subsection 401.3k.** Comply with all specifications regarding production of fresh concrete.

Determine the air loss due to paving operations at a minimum of two randomly-determined sublots per day. Determine the difference between the air content from concrete sampled before the paver, and concrete sampled behind the paver. QC/QA samples may be obtained in front of the paver and then corrected subtracting the difference determined during that ½ days production. Loss of air due to paving operations may adversely affect the spacing factor.

Failure to maintain the minimum required air content will result in suspension of operation. Take immediate steps to increase the air content above the minimum values stated in **subsection 403.3e.**

Other similar designs using higher cementitious contents (this may adversely affect permeability) and the same admixture types and dosage (with the same or lower water-cementitious ratio) may be used in limited areas such as crossovers, etc. Unauthorized changes in any aspect of production are cause for rejection of the pavement.

Random checks of the air void spacing factor of the concrete in the path and gap of the vibrators will be conducted by the Engineer to verify a maximum AVA spacing factor of 0.0100 inch at the measured air content.

APPENDIX A – NON-MANDATORY INFORMATION

STRATEGIES TO IMPROVE THE AIR VOID SPACING FACTOR

Better air-void characteristics are obtained by a more thorough mixing of the sand and the air-entraining agent. Below are listed some strategies to help the mixing process.

1. Increase the mixing time of the plant or mixing revolutions of the truck.
2. Use a higher dosage of water reducer, up to 390 ml per 100 kg (6 oz. per 100 lbs) of cement. Use a non-retarding water reducer above 195 ml per 100 kg (3 oz. per 100 lbs) if needed.
3. Reduce the Paste Content (less water or less cement).
4. Use a higher proportion of rock.
5. Use a third, mid-sized aggregate.
6. Use coarser graded sand, or a finer sand if the current one is extremely coarse.
7. Maintain a higher air content (use more air-entraining agent).
8. Use coarser cement.
9. Change types or brands of the water reducer or the air entraining agent, or both.
10. Cool the mix ingredients; i.e., use chilled water.
11. Use a different plant, or modify the plant configuration. Introduce aggregates together on the belt feed (multiple weigh hoppers), use live bottoms aggregate bins, use dual drums, etc.

501 - PORTLAND CEMENT CONCRETE PAVEMENT (QC/QA)

SECTION 501

PORTLAND CEMENT CONCRETE PAVEMENT (QC/QA)

Note: PCCP is considered QC/QA when the bid item Quality Control Testing is included in the contract. Note the exceptions in subsection 501.5.

501.1 DESCRIPTION

Construct Portland Cement Concrete Pavement (PCCP) on a prepared subgrade or base course. Develop and perform quality control testing.

Urban PCCP Environment: Projects or sections of the project classified as Urban Type are typically:

- within city limits;
- require pieced construction due to:
 - business and residential entrances;
 - frequency of side streets; or
 - project phasing.

Before paving, meet with the Engineer to determine if the project or sections of the project are classified as Urban Type.

BID ITEMS

Concrete Pavement (* Uniform) (AE) (**)
Concrete Pavement (* Variable) (AE) (**)
Early Strength Concrete Pavement (*Uniform) (AE) (**)
Early Strength Concrete Pavement (*Variable) (AE) (**)
Quality Control Testing (PCCP)⁺
Concrete Core (Set Price)

UNITS

Square Yard
Square Yard
Square Yard
Square Yard
Square Yard
Each

* Thickness

** No entry denotes PCCP with mesh and dowel assemblies. "Plain" denotes PCCP without mesh and dowel assemblies. "NRDJ" denotes non-reinforced dowel jointed PCCP. "Br App" denotes bridge approach pavement.

⁺ Br App pavement quantities are not included in this item.

501.2 CONTRACTOR QUALITY CONTROL REQUIREMENTS

a. General. Provide qualified personnel and sufficient equipment complying with the requirements listed in Part V to conduct quality control testing that complies with Appendix B, Sampling and Testing Frequency Chart for Concrete Construction Items for Quality Control/Quality Assurance Projects.

Allow the Engineer access to the Contractor's laboratory to observe testing procedures, calculations, test documentation and plotting of test results.

Calibrate and correlate the testing equipment with prescribed procedures, and conduct tests in compliance with specified testing procedures as listed in Part V.

Maintain a Quality Manual in the field laboratory showing the calibrations performed on all test equipment and when the next calibration is due for that equipment. As a minimum, follow the calibration/verification interval established in Table 1: Concrete Materials Test Equipment in Section 5.2.7.4-Concrete: Contractor's Quality Control Plan, Part V. See also Section 5.2.7.5-Example of a Laboratory Quality Manual for Concrete, Part V.

b. Quality Control Plan (QCP). At the pre-construction conference, submit to the Engineer for approval by the DME, a QCP as outlined in Section 5.2.7.4-Concrete: Contractor's Quality Control Plan, Part V. Follow 5.2.7.4: Concrete: Contractor's Quality Control Plan in Part V as a general guideline. Keep a printed copy of the approved QCP in the Contractor's laboratory and make available to the Engineer when requested.

501 - PORTLAND CEMENT CONCRETE PAVEMENT (QC/QA)

The Contractor's laboratory and equipment will be inspected and approved as outlined in Section 5.2.7- Contractor's Quality Control Plan, Part V.

Include a listing of the names and phone numbers of individuals and alternates responsible for quality control administration and inspection. On the Contractor's organizational chart, show the specified lines of authority relating both to mix design and quality control operations during production. Post the organizational chart in the Contractor's test facility.

Provide a quality control organization or private testing firm having personnel certified according to the Policy and Procedures Manual for The Certified Inspection and Testing (CIT) Training Program. The testing for this type of construction will require personnel certified in Aggregate Field Tester (AGF), Aggregate Lab Technician (AGL), Profilograph (PO), ACI Concrete Field Testing Technician (CF), Nuclear Moisture Density Gauge Tester (NUC) and Hardened Concrete Properties (HCP) classifications. Provide a minimum of 1 employee on the project certified in the QC/QA Concrete/Cement Treated Base Specs (QCS) classification.

Only persons certified in the appropriate classifications covering the specific tests required shall perform such testing. At the beginning of the project, provide the Engineer with the list of certified technicians and alternates, phone numbers and tests/inspection they will be performing. As personnel changes and certifications may expire, continue to provide the Engineer with an accurate list.

Provide an organizational chart showing the specified lines of authority relating to both mix design and quality control operations during production. Identify the company official acting as liaison with KDOT, and the Certified Technician who will direct inspection and testing. Post the chart in the test facility.

c. Required Duties of Certified Technicians. Be available on the project site whenever concrete for pavement is being produced and being placed on the project site. Perform and utilize quality control tests and other quality control practices to assure that delivered materials and proportioning meet the requirements of the mix designs.

Periodically inspect all equipment utilized in transporting, proportioning, mixing, placing, consolidating, finishing and curing to assure it is operating properly and that placement, consolidation, finishing and curing comply with the mix design and other contract requirements.

d. Contractor's Testing Facilities. Describe the testing facility and its accreditation in the QCP.

Locate the testing facility either at the plant site or at the project. Obtain approval of the testing facilities and location from the DME before the commencement of mixture production.

Provide suitable space for the required testing equipment. Also, equip the testing facility with these items for the exclusive use of the testing facility's quality control personnel and the Engineer:

- A telephone with a private line;
- A copying machine; and
- Broadband internet connection (for 1 computer). If the Engineer determines that broadband internet service is not available, provide a fax machine, at no additional cost.

e. Documentation. Include in the QCP procedures, charts and forms to be used to provide the required documentation.

Record and document all test results and calculations. Record all original documentation in a bound field book or other KDOT approved bound record and turn over to KDOT at the end of the project.

At all times, have complete records of all inspections and tests readily available on site for the Engineer. All records documenting the Contractor's quality control inspections and tests become the property of KDOT upon completion of the work.

Indicate the nature and number of observations made, the number and type of deficiencies found, the quantities approved and rejected, and the corrective action taken in the records. Examples of quality control forms and charts are available in Part V, or Contractors may design their own. Documentation procedures are subject to approval by the Engineer before the start of the work and to compliance checks during the progress of the work.

Maintain control charts on an ongoing basis. Plot data according to **SECTION 106**.

Record specific test results on a Daily Quality Control Summary sheet designed to facilitate the computation of moving test averages. Base moving averages on 4 consecutive test results. Include a description of quality control actions taken (such as adjustment of aggregate or additive proportions in the mix, moisture adjustments) in the Daily Quality Control Summary Sheet.

501 - PORTLAND CEMENT CONCRETE PAVEMENT (QC/QA)

Provide forms on a computer-acceptable medium, where required. Document tickets and gradation data according to KDOT requirements.

Complete testing and charting within 1 working day after sampling.

Keep all quality control charts current. Show both individual test results and moving average values. As a minimum on approved control charts, plot the single test values and the 4 test moving average values for these properties:

- Percent air in concrete mixture;
- Slump of concrete mixture;
- Concrete unit weight;
- In-place concrete density on plastic concrete as a percentage of determined unit weight; and
- Combined aggregate gradation (as a minimum, plot the 3/8" and No. 8 sieves).

Also plot the single test values for actual workability and target workability of the combined aggregates.

Provide the following test data to the KDOT Project Representative:

- Copies of all test results and control charts on a weekly basis, representing the prior week's production;
- Copies of the quality control summary sheet on a daily basis. Include, as a minimum, combined aggregate gradations, actual workability and target workability of combined aggregates, percent air content, slump, concrete unit weight and density of fresh concrete in-place; and
- Copies of all failing test results. Include all applicable sieves, actual workability, percent air content, slump and density of fresh concrete in-place.
- Copies of vibrator checks daily to the Inspector. Email a weekly recap to the Construction Engineer.

Email or fax the data to the Field Engineer and DME, weekly.

f. Testing Requirements. In the QCP, identify test methods, procedures and equipment proposed for use. Use standard KDOT test methods and properly calibrated measuring and testing equipment as outlined in Part V. Detail any alternative sampling method, procedure or inspection equipment proposed to be used. Such alternatives are subject to review and approval by the DME.

Take all samples for tests and perform in-place tests at random locations, selected according to the Contractor's QC Plan and at the rates specified in the Sampling and Testing Frequency Chart for Portland Cement Concrete Pavement for Quality Control/Quality Assurance Projects in Appendix B, Part V. Retain the latest 10 gradation samples for use by the Engineer.

g. Corrective Action. In the QCP, identify procedures for notifying the Engineer when corrective measures must be implemented, and for halting production.

Notify the Engineer when the moving average test result trend line for any property approaches the specification limits. Cease operations if 2 consecutive moving average points fall outside the specification limits. Ceasing operations is the Contractor's responsibility. Quality control tests for this determination include aggregate gradation, compliance with the mix design band, percent air content, concrete unit weight and density of fresh concrete in-place.

Failure to cease operations for the conditions cited above will subject all subsequent material to rejection, or acceptance at a reduced price, as determined by the Engineer.

The Engineer may examine materials represented by individual test results, which lie beyond the Contractor's normal quality control testing variation. The investigation may be based on either Contractor or KDOT test results. The information from additional testing (including testing of in-place pavement) may be used to define unacceptable work according to **SECTION 105**. The Engineer will apply appropriate price reductions or initiate corrective action.

If a dispute exists between the Engineer and Contractor about the validity of any test results other than compressive strengths or thickness determination, the KDOT District Materials Laboratory or MRC will perform referee testing. If one of the disputed KDOT test results was generated at the MRC, then an independent laboratory agreeable to both parties will be selected. The AASHTO Accreditation Program shall have approved the selected laboratory for the appropriate test procedure. If referee testing indicates that KDOT test results are correct, the

501 - PORTLAND CEMENT CONCRETE PAVEMENT (QC/QA)

Contractor is responsible for the cost of additional testing, including referee testing performed at the MRC. If the referee testing indicates that the Contractor test results are correct, KDOT is responsible for the cost of additional testing.

Follow the procedures outlined in **subsection 501.5g.(4)** if a dispute arises for any test determining compressive strengths or thickness.

h. Non-Conforming Materials. In the QCP, specifically address how non-conforming materials will be controlled and identified.

Establish and maintain an effective and positive system for controlling non-conforming material, including procedures for its identification, isolation and disposition. Reclaim or rework non-conforming materials according to procedures acceptable to the Engineer.

Identify all non-conforming materials and products to prevent use, shipment and intermingling with conforming materials and products. Provide holding areas, mutually agreeable to the Engineer and Contractor.

i. Concrete Information. Separately list the grades of concrete involved in the project. For each grade of concrete to be used, include at a minimum, the following:

- Mix designs. List mix design numbers if using existing mixes.
- Aggregate production.
- Quality of components.
- Stockpile management.
- Proportioning, including added water.
- Mixing and transportation.
- Initial mix properties.
- Placement and consolidation.
- Concrete yield.
- Compressive strength.
- Finishing and curing.
- Frequency of sampling and testing.
- How duties and responsibilities are to be accomplished and documented, and if more than one Certified Technician is required.
- The criteria used by the Certified Technician to correct or reject unsatisfactory materials.

501.3 MATERIALS

Provide materials that comply with the applicable requirements.

Concrete and Grout	SECTIONS 401& 403
Aggregates for On Grade Concrete	SECTION 1116
Reinforcing Steel	DIVISION 1600
Epoxy Coated Steel Bars for Concrete Reinforcement	DIVISION 1600
Joint Sealants	DIVISION 1500
Expansion Joint Filler	DIVISION 1500
Concrete Curing Materials	DIVISION 1400
Preformed Elastomeric Compression Joint Seals	DIVISION 1500
Cold Applied Chemically Cured Joint Sealant	DIVISION 1500
Hot Type Joint Sealing Compound	DIVISION 1500
Backer Rod	DIVISION 1500
Epoxy Resin-Base Bonding System for Concrete	SECTION 1705
Bond Breakers	SECTION 1718

501.4 CONSTRUCTION REQUIREMENTS

a. Preparation of the Subgrade. Before placing any surfacing material on any section, complete the ditches and drains along that section to effectively drain the highway. Trim the base or subgrade to the line, grade

501 - PORTLAND CEMENT CONCRETE PAVEMENT (QC/QA)

and typical cross-section as shown in the Contract Documents. Maintain the subgrade or base to the as-constructed condition under other bid items, repairing any encountered defects to the specifications of those bid items. Maintain the subgrade surface to readily drain at all times. Protect the subgrade from damage when handling materials, tools and equipment. Do not store or stockpile materials on the subgrade. Do not place material or lay pavement on a frozen or muddy subgrade, or when it is raining or snowing.

Lightly spray the subgrade or base with water to obtain a thoroughly moistened condition when the concrete is deposited on it. Do not puddle water on the grade.

Do not deposit any material until the subgrade or base has been checked and approved by the Engineer.

b. Slip Form Paving. When paving is performed with a slip form paving unit, use equipment as described in **subsection 154.5**.

Pave 24-foot wide mainline pavement in a single operation. Do not exceed 24-foot paving width in a single operation except as follows:

- The Contractor may pave a maximum of 2 lanes plus a 6-foot shoulder (30 feet maximum) in a single operation.
- For pavements of 3 lanes or more, pave a minimum of 2 lanes mainline (with the option of including a single shoulder for a maximum of 30 feet) in a single operation.
- Approval will be based on satisfactory performance of the Contractor's operation.

Place ramps and auxiliary lanes/shoulders as shown in the Contract Documents.

Once the paving operation has started, provide adequate equipment and supply of materials to maintain continuous placement for any given working period. Keep all concrete conveying equipment clean.

Do not apply any tractive forces to the slip form paver, except that which is controlled from the machine.

Trim to grade the subgrade or surface of the base over which the tracks of the paver will travel. Do not disturb this surface with other equipment. If the equipment or method of operation requires the subbase to be wider than shown in the Contract Documents, place additional material to provide an adequate surface for the tracks of the paver. Upon completion of the paving operations, remove or repair any base material damaged by the slip form paver's tracks. All necessary construction and removal of this additional base material is subsidiary to other items of the contract.

Operate the paver continuously, stopping only when absolutely necessary. If the forward motion of the paver is stopped, immediately stop the vibrator and tamping elements.

Deposit the concrete on the grade in successive batches to minimize re-handling. Place concrete over and against any joint assemblies so the joint assembly is retained in its correct position. Spread the concrete using approved mechanical spreaders to prevent segregation and separation of the materials.

After striking the concrete off with the spreader, leave sufficient concrete in place to allow the final shaping by the use of screeds, templates and pans, depending on make, model and type of machines approved for use in the paving train. Adjust the paving units to meet the required final cross-section, minimizing the need to carry back concrete to fill voids or depressions. Adjust each screed or template so a uniform roll of concrete extends the full length of the screed or template and allows just enough concrete to pass under the unit to properly feed the next machine. Do not shove large volumes of concrete with the screed or template. Adjust the screed or template to maintain a uniform cross-section.

Use multiple spreaders for single and multiple lift operations. Place concrete ahead of the initial spreader strikeoff no more than 30 minutes ahead of the final spreader strikeoff.

The use of any paving machine in the paving train is contingent on its ability to finish the pavement satisfactorily to the required grade, section and specified degree of consolidation. The Engineer may at any time require the adjustment, repair or replacement of the machine for unsatisfactory performance.

Correct any edge slump of the pavement in excess of $\frac{1}{4}$ inch, exclusive of edge rounding, before the concrete hardens. Excessive edge slumping will be sufficient reason to discontinue paving until machinery (or mix) is properly adjusted or removed from the project.

When the machine finishing has been completed, check the surface with a straightedge a minimum of 10 feet in length before texturing. Operate the straightedge parallel to the pavement centerline, starting at the center and progressing outward. Advance in successive stages of less than $\frac{1}{2}$ the length of the straightedge. At the Contractor's option, this requirement may be eliminated when smoothness is to be determined by the profilograph.

Achieve grade control by use of 1 or more of the following grade reference devices. Approval of any of these devices will be based upon satisfactory performance.

501 - PORTLAND CEMENT CONCRETE PAVEMENT (QC/QA)

Erected Stringline. Use an erected stringline consisting of a tightly stretched wire or string offset from and parallel to the pavement edge on 1 or both sides. Erect the stringline parallel to the established pavement surface grade and support at intervals as necessary to maintain the established grade and alignment.

Stringless Paving. Control line, grade and pavement cross-section as shown in the Contract Documents. Use electronic guidance systems that meet the requirements and tolerances listed in **SECTION 802**. Horizontal control is guided by GPS. Vertical control is guided by Total Stations. GPS will not be allowed for Vertical control.

When paving on a fresh subgrade that has not been trimmed by an automatically controlled machine, use an erected stringline or stringless paving to establish grade. When directed by the Engineer, use an erected stringline or stringless paving to match grade control points such as bridges.

c. Placing Reinforcement. Place pavement reinforcement at the locations shown in the Contract Documents. Use a sufficient number of approved metal, bar supports or pins to hold all dowel bars and tie bars in proper position as required by the Contract Documents. Install tie-bars perpendicular to the concrete face being tied together. Do not use stones, concrete or wood to support the reinforcement.

Joint tie bars may be installed mechanically if approved by the Engineer. The satisfactory placement of the bars depends on the ability of the Contractor's operation to place and maintain the bars in their true position. When satisfactory placement is not obtained by mechanical means, the Engineer may require the tie bars be installed ahead of placing the concrete, and that they be securely held in their exact position by staking and tying.

Do not install dowel bars mechanically. Install the dowel bars ahead of placing the concrete, and hold them securely in their exact position by staking or tying.

Thoroughly coat each dowel with hard grease or other approved bond breaker as shown in the Contract Documents. The bond breaker coating shall not exceed 15 mils \pm 5 mils in thickness when averaged over 3 points measured at the $\frac{1}{4}$ points on the bar at 90° intervals around the bar.

When reinforced concrete pavement is placed in 2 layers, strike off the entire width of the bottom layer to such length and depth that the sheet of fabric or bar mat may be laid full length on the concrete in its final position without further manipulation. Place the reinforcement directly on the concrete, then place the top layer of concrete, strike it off and screed it. Remove any portion of the bottom layer of concrete that has been placed more than 30 minutes, and replace it with fresh mixed concrete at the Contractor's expense. When reinforced concrete is placed in 1 layer, the reinforcement may be positioned in advance of the concrete placement or it may be placed in the plastic concrete after initial spreading, by mechanical or vibratory means.

Place the wire mesh reinforcement in the pavement at the locations shown in the Contract Documents. When 2 layers of wire mesh reinforcement are required, support the bottom layer in the required position with bar chairs. Use separators for the top layer if the strike-off can not be used properly for the operation. Lap the reinforcement as shown in the Contract Documents. Laps parallel to the centerline of the pavement are prohibited except for unusual width of pavement lanes or for irregular areas. If the Contract Documents do not show dimensions for laps, the minimum lap either perpendicular or parallel to the centerline of the pavement is 6 inches. Fasten or tie adjacent wire mesh sheets together to hold all parts of the wire mesh sheets in the same plane.

If a "wire pattern" appears on the surface of the fresh pavement, immediately modify placement procedures to eliminate the problem.

Use reinforcing steel free from detrimental materials that could impair the bond between the steel and concrete.

d. Consolidation and Finishing. Perform hand spreading with shovels, not rakes. Do not allow workers to walk in the fresh concrete with boots or shoes coated with earth or foreign substance.

Do not apply moisture to the surface of the concrete pavement unless the Engineer approves the use of additional water on the fresh concrete surface to lubricate the float of the longitudinal finisher. If unusual weather conditions require the addition of superficial water to the concrete surface, apply it only in the form of a fine, fog mist.

Uniformly consolidate the concrete without voids, and finish to the cross-section and elevation shown in the Contract Documents.

Use vibrators or other approved equipment to consolidate each layer of concrete, when placed in more than 1 lift, or full depth if placed in 1 lift. Uniformly vibrate the concrete across the full width and depth of the pavement so that the density of pavement concrete is a minimum of 98% of the consolidated unit weight. The 98% density

501 - PORTLAND CEMENT CONCRETE PAVEMENT (QC/QA)

requirement may be eliminated on miscellaneous areas such as entrance pavement, median pavement and gore areas.

Vibrators, either of the surface type (pan or screed) or the immersion type (tube or spud) may be attached to the spreader, paver or finishing machine, or may be mounted on a separate carriage. Only operate the vibrators when the machine they are mounted on is moving forward. Do not operate hand vibrators more than 15 seconds, or less than 5 seconds in any one location unless approved otherwise by the Engineer. Place vibrators in and withdraw from concrete vertically in a slow deliberate manner.

On mainline paving, every 4 hours, check the electronic monitoring system vibrator frequencies with the vibrator under load to comply with the frequencies shown in **subsection 154.2e**.

If the system indicates a vibrator is not working properly, manually check the vibrators, immediately. If a vibrator is not functioning properly, immediately replace.

If the electronic monitoring system fails to operate properly, manually check the vibrators, immediately. If the vibrators are functioning properly, paving may continue but make all efforts to correct the problem within 3 paving days. The Engineer may allow additional time if circumstances are beyond the Contractor's control. Perform the vibrator checks manually until the system is fixed.

Document the checks, and give the data to the Inspector, daily. Email a recap of the data to the Engineer, weekly.

Maintain a uniform, continuous roll of concrete over the vibrators ahead of the strike-off. The height of the roll shall be approximately the same height as the thickness of the pavement being vibrated.

In order to obtain concrete consolidation in the vicinity of joint assemblies, the Engineer may require that these areas be hand vibrated with an immersion spud vibrator.

In the event the specified density is not attained, cease paving operations and make necessary adjustments to produce concrete to conform to the density requirements.

Use an approved nuclear density measuring device to monitor in-place density. Provide a moveable bridge and move it to test locations as required to allow the Inspector to work over the fresh concrete.

On projects or areas within projects where the use of conventional equipment is impracticable, other consolidation and finishing equipment may be used with approval of the Engineer.

e. Fixed Form Paving. At the Contractor's option, the fixed form paving method may be used.

(1) Forms. Use straight, metal forms having adequate strength to support the equipment. Each section shall be a minimum of 10 feet in length. Use forms with a depth equal to the prescribed edge thickness of the concrete, a base width at least equal to the depth of the forms and without a horizontal joint. Use flexible or curved forms of proper radius for curves of 150-foot radius or less, except approved straight forms of 5-foot lengths may be used for curves of a radius from 75 to 150 feet. Flexible or curved forms must be approved by the Engineer. The Engineer may approve the use of wood forms in areas requiring hand finishing. Secure the forms in place to withstand the impact and vibration of the consolidating and finishing equipment without visible spring or settlement. Extend flange braces outward on the base a minimum of $\frac{2}{3}$ the height of the form. Remove forms with battered top surfaces or bent, twisted or broken forms. Do not use repaired forms until they have been inspected and approved by the Engineer. Do not use buildup forms, except where the total area of pavement of any specified thickness on the project is less than 2,000 square yards. Do not vary the top face of the form from a true plane more than $\frac{1}{8}$ inch in 10 feet, and do not vary the vertical face of the form by more than $\frac{1}{4}$ inch. The forms shall contain provisions for locking the ends of abutting form sections together tightly, and for secure setting.

(2) Base Support. Provide a foundation under the forms that is compact and true to the specified grade so that the whole length of the form will be set firmly in contact with the grade.

(3) Form Setting. Set forms sufficiently in advance of the point where concrete is being placed so that line and grade may be checked. After the forms have been correctly set, thoroughly tamp the grade mechanically at both the inside and outside edges of the base of the forms. Stake forms into place with a minimum of 3 pins for each 10 foot section. Place a pin at each side of every joint. Tightly lock form sections, free from play or movement in any direction. Do not deviate the form from true line by more than $\frac{1}{4}$ inch at any point. No excessive settlement or springing of forms under the finishing machine is permitted. Clean and oil forms before the placing of concrete.

(4) Grade and Alignment. Check the alignment and grade elevations of the forms immediately before placing the concrete and make any necessary corrections. When any form has been disturbed or any grade has become unstable, reset and recheck the form.

(5) Placing Reinforcement and Consolidating and Finishing Concrete. Meet the requirements in **subsections 501.4c. and d.**

501 - PORTLAND CEMENT CONCRETE PAVEMENT (QC/QA)

(6) Removing Forms. Unless otherwise provided, do not remove forms from freshly placed concrete until it has set for a minimum of 12 hours, except auxiliary forms used temporarily in widened areas. Remove forms carefully to avoid damage to the pavement.

f. Texturing. Use texturing equipment and devices as described in **subsection 154.7**.

Use a burlap drag as soon as all excess moisture has disappeared and while the concrete is still plastic enough to make a granular surface possible.

Following the dragging operation, use a mechanical device to make a final finish or texture by giving the surface of the plastic pavement a longitudinal tining, unless shown otherwise in the Contract Documents. Perform the operation at such time to minimize displacement of larger aggregate particles and before the surface permanently sets.

Small or irregular areas may be tined by hand methods.

On projects of less than 5,000 square yards, or projects with longitudinal tining, the tining and curing devices may be mounted on the same carriage when approved by the Engineer. Operations of this type will be based on satisfactory performance.

Before final texturing, finish the exposed edge of the pavement to a radius of ¼ inch with an edger. Edge the interior longitudinal joints on multiple-lane pavement to a radius of ⅛ inch. Eliminate any tool marks appearing on the slab adjacent to the joints or edge of the slab. Do not disturb the rounding of the corner of the slab.

g. Joints.

(1) General. Construct joints according to the Contract Documents. Failure to construct the joints in the best possible manner will be cause for suspension of work until the cause of the defective work is remedied.

If existing pavement of any type is required to abut with the new pavement, and the termination of the removal is not at an existing joint, make the new joint by sawing the existing pavement full depth with a diamond saw before removal.

The objective is to create or form a plane of weakness in the fresh concrete before uncontrolled or erratic cracking occurs. The following methods are acceptable:

- Use concrete saws to saw all contraction joints no wider than the initial saw cut and to a depth of $D/3 \pm 1/4$ inch. Extreme conditions could exist which make it impracticable to prevent erratic cracking by sawing the joints early. At the onset of the project, devise methods, with the approval of the Engineer, to control this cracking.
- Make a “plastic concrete cut” straight and well defined so it can be sawed out by the saw crew. The “plastic concrete cut” would replace the specified initial saw cut. Suggested procedures could be the use of a stiff metal parting strip, with or without handles that would be gently inserted in the fresh concrete and removed, thereby parting the interlocking coarse aggregate and providing a plane of weakness.
- Cut the fresh concrete with a mason’s trowel and straightedge from a worker’s bridge. It is imperative that the “plastic concrete cut” joint and the second stage saw cut are in the same exact location.
- At the Contractor’s option, “early entry” saws may be used based on satisfactory performance and depth of cut recommended by the equipment manufacturer.
- Procedures to control erratic cracking are not limited to these examples.

Edge any transverse joint requiring hand finishing and edging with a tool having a radius of ⅛ inch. Do not indent the surface of the pavement with the horizontal face of the edger.

(2) Pressure Relief Joints. Install pressure relief joints according to the bridge approach details in the Contract Documents.

Form or saw openings for the joint material approximately 1 ¾ inches wide for the 2-inch joint and approximately 3 ¾ inches wide for the 4-inch joint at the locations shown in the Contract Documents. Use the lubricant adhesive as recommended by the manufacturer of the pressure relief joint material.

Just before the installation of the joint material, clean the faces of the joint by sandblasting, followed by an air blast to clean all dust from joint faces.

The Engineer may approve pre-positioning of the 2-inch material if adequate means are taken to obtain proper placement and retention, and if deformation of the material does not occur when the fresh concrete is placed against it.

501 - PORTLAND CEMENT CONCRETE PAVEMENT (QC/QA)

Use a foam spacer block beneath the 4-inch joint filler material to maintain the specified grade. The spacer block is an easily compressed foam material cut to fill the void beneath the joint filler.

(3) Contraction Joints. Install contraction joints of the type, dimensions and spacing shown in the Contract Documents.

Stretch a stringline along the centerline of the joint, or otherwise adequately mark it to verify dowel bar joint assembly alignment.

Install the dowel bar joint assembly so the centerline of the assembly is perpendicular to the centerline of the slab, and the dowels lie parallel to the slab surface and slab centerline. Place concrete so it will not displace or disarrange the joint assembly. Mark the location of contraction joints to assure the joints are sawed in the proper location.

(4) Longitudinal Joints. Construct longitudinal joints according to the Contract Documents. When sawed joints are specified or used, provide approved guide lines or devices to cut the longitudinal joint on the true line as shown in the Contract Documents. Perform the sawing of longitudinal joints at a time that will prevent erratic or uncontrolled cracking. When "plastic concrete cut" methods are used, no sawing or widening of the joint will be required to make a sealant reservoir.

(5) Construction Joints. Make a butt construction joint perpendicular to the centerline of the pavement at the close of each day's work, or when the process of depositing concrete is stopped for a length of time sufficient for the concrete to take its initial set. Form this joint by using a clean header having a nominal thickness of 2 inches, and minimum cross-sectional area equal to pavement thickness by pavement width. Cut the header true to the crown of the finished pavement. Accurately set and hold it in place in a plane at right angles to centerline and perpendicular to the surface of the pavement.

Protect the top surface of the header with steel. Securely fasten a trapezoidal piece of metal or wood approximately 2 inches wide and a minimum of 1 inch in depth on the face of the header, along the center of the header to form a grooved or keyed joint.

With approval of the Engineer, the Contractor may pave beyond the joint location a distance to maintain the line and grade. Saw the construction joint when the concrete has hardened. Drill holes for reinforcing tie bars and epoxy the bars in-place. Place fresh concrete against the previously placed concrete taking care to avoid injury to the edge. Vibrate the concrete to obtain an interlocking joint and prevent a honeycombed face of the joint. The additional concrete, removal of debris and other work created by this alternative is at the Contractor's expense.

Unless shown otherwise in the Contract Documents, do not place any construction joint within 5 feet of an expansion, contraction or other construction joint.

(6) Special Joint Construction. Construct special joints as shown in the Contract Documents or as ordered by the Engineer around drainage, utility and other structures located within the concrete pavement boundaries. Hold temporary forms securely in place during the concrete placement operation.

(7) Joint Construction. Construct all joints as shown in the Contract Documents. Repair or replace any curing medium damaged during joint construction. Construct joints as follows:

(a) Induced Plane of Weakness. The first saw cut is a relief cut at the proper joint location, approximately $\frac{1}{8}$ inch wide and to the full joint depth as shown in the Contract Documents ($D/3 \pm \frac{1}{4}$ inch). Make the relief cut as soon as the concrete has hardened enough so that no excess raveling or spalling occurs, but before any random cracks develop. The sequence of the relief sawing is at the Contractor's option, provided all relief sawing is completed before random cracking develops. Use suitable guide lines or devices to cut the joint straight and in the correct location. Repair curing membrane damaged during sawing as directed by the Engineer. See **subsection 501.4g.(1)** for alternate methods to the first stage sawing.

(b) Reservoir Construction. Do not perform widening of the relief joints to full width until the concrete is a minimum of 48 hours old. Delay it longer if the sawing causes raveling of the concrete. If second stage sawing is performed before completion of the curing period, maintain the cure by use of curing tapes, plastic devices or other materials approved by the Engineer. Center the joint groove over the relief cut, and saw it to the dimensions shown in the Contract Documents. Should any spalling of the sawed edges occur that would detrimentally affect the joint seal, patch it with an approved epoxy patching compound and allow it to harden before installing the joint material. Make each patch true to the intended neat lines of the finished cut joint.

(8) Cleaning Joints.

501 - PORTLAND CEMENT CONCRETE PAVEMENT (QC/QA)

- (a) Immediately clean freshly cut sawed joints by flushing with a jet of water under pressure and other necessary tools to remove the resulting slurry from the joint and immediate area.
- (b) To clean joints, use air compressors equipped with suitable traps capable of removing all surplus water and oil from the compressed air. The Engineer will check the compressed air for contamination, daily. When contaminated air is found to exist, work will be stopped until suitable adjustments are made, and the air stream is found to be free of contaminants.
- (c) Just before applying the hot or cold joint sealant, complete a final cleaning by air blasting to clean incompressibles from the joint.
- (d) Before installing preformed elastomeric joint seals, use water or sandblasting equipment to clean the seal reservoir of the transverse joint a minimum of the vertical height of the installed elastomeric joint material plus ½ inch measured from the pavement surface. Use a multiple pass technique until the surfaces are free of dirt, curing compound or any residue that might prevent ready insertion of the seal, or uniform contact with the concrete. (Note: These seals are held in place by compressive forces and friction acting on the faces of the joint, not chemical bonding as with other joint sealants.) After final cleaning, and immediately before installing the seal, blow out the joint seal reservoir with compressed air until it is free of debris and visible water.

(9) Sealing Joints. The joint location, size and configuration is shown in the Contract Documents. Use applicable materials to obtain the required joint sealant configuration. Seal transverse pavement joints with preformed elastomeric compression joint seals, unless shown otherwise in the Contract Documents. Seal longitudinal pavement joints full depth with either a cold applied chemically cured joint sealant or a hot joint sealing compound. Use only 1 type of longitudinal joint sealant on a project, unless otherwise approved by the Engineer. Seal joints before opening to traffic. For opening to construction traffic, see **subsection 501.4i.(3)(a)**.

When using cold applied chemically cured joint sealant, hot joint sealing compound or preformed elastomeric compression joint seals, arrange for a technical representative of the manufacturer to be present during installation of the joint seal to provide guidance on cleaning, preparation of the joint and installation of the seal.

Keep the manufacturer's technical representative on the project until Contractor and KDOT personnel have been thoroughly trained in the proper installation of the material. The Engineer may waive this requirement for Contractors that are experienced in installing the type and brand of material being used. Provide the Engineer with a résumé of experience for evaluation.

- (a) Cold Applied Chemically Cured Joint Sealants. Do not seal joints until they are clean and dry, and the pavement has attained the age recommended by the manufacturer of the sealant. Do not apply sealant to damp concrete, or install it during inclement weather. Do not apply joint sealant when the ambient air temperature is below 40°F, or as specified by the manufacturer. Place the sealer full depth in close conformity with dimensions shown in the Contract Documents. Any deviation will be cause for rejection of the joint until satisfactory corrective measures are taken.

Apply the joint sealant by an approved mechanical device. Any failure of the joint material in either adhesion or cohesion will be cause for rejection. Repair the joint to the Engineer's satisfaction.

Some cold applied, chemically cured sealants are not self-leveling and will not position properly in the joint under its own weight. Tool the sealant surface as shown in the Contract Documents. Accomplish tooling before a skin forms on the surface. Do not use soap or oil as a tooling aid.

After a joint has been sealed, promptly remove all surplus joint sealer from the pavement or structure surfaces.

Do not permit traffic over sealed joints until the sealer is tack free, or until debris from traffic can not embed into the sealant.

- (b) Hot Applied Joint Sealing Compound. Do not seal joints until they are clean and dry, and the pavement has attained the age recommended by the manufacturer of the joint sealing compound. Install joint sealing compound according to the manufacturer's recommendations.

Completely clean out the application unit when changing brands of materials, or if the material exhibits any sign of changes in application characteristics, polymer or oil separation, balling or any signs of jelling. If the application unit contains compatible material from a previous project at start-up, provide the Engineer a certification covering the material in the application unit, including the manufacturer, type, etc. Before start-up, completely clean out any material that can not be identified and certified.

501 - PORTLAND CEMENT CONCRETE PAVEMENT (QC/QA)

After a joint has been sealed, promptly remove all surplus joint sealer from the pavement or structure surfaces.

Do not permit traffic over sealed joints until the sealer is tack free, or until debris from traffic can not embed into the sealant.

(c) Preformed Elastomeric Joint Seals. Concrete that has reached an age that permits proper sawing and cleaning without causing deterioration of the joint edges and joint faces, is considered acceptable for seal installation.

Under normal construction procedures, seal transverse joints full width with no splices made in the preformed joint seal. However, under phased construction of widenings, where the lanes placed earlier have been opened to traffic, the preformed joint seal may be spliced at the construction joint. When the existing seal is peeled back to saw the construction joint, clean it, reapply the lubricant/adhesive and reinstall as soon as possible. After the new seal is installed, place the longitudinal joint sealant through the intersection with the transverse joint, with the transverse seals butted in. Place the longitudinal sealant to encase and seal the ends of the preformed seals.

Install the joint seal with a machine especially designed to compress and install the sealant in an upright position, without cutting, nicking, distorting or otherwise damaging the seal. Apply lubricant to the concrete or the preformed seal (or both), and install the seal in a substantially compressed condition. Place the top of the seal at a depth below the finished surface of the pavement, recommended by the manufacturer.

Use a method of installation such that the joint seal will not be stretched or compressed longitudinally more than 3% of the length, unless stated otherwise in the manufacturer's instructions. The method of installation will be checked for stretching or compression by comparing the distance between 2 marks on the surface of the seal measured before and after the installation. If the check indicates stretching or compression beyond the limits stated above, modify the method of installation to correct the situation. The Contractor may proceed slightly out of specification for a short distance under the supervision of the manufacturer's technical representative, while making corrections and adjustments to return to specification limits. This material may remain in place, provided the stretching does not exceed 5%, and the Contractor makes a good faith effort to correct the problem. Once the machine is in proper adjustment and the installation is proceeding satisfactorily, further checks (approximately every 100 joints) will be made to verify proper installation.

Remove any joint seal not conforming to the above stated limits of installation and replace with new material. After being removed for any reason, no seal may be reused.

(10) Sawed (Non-Sealed) Joints.

(a) Joint Construction. The joint location, size and configuration are shown in the Contract Documents. Use concrete saws to saw all joints a nominal 1/8 inch wide to the full joint depth, $D/3 \pm 1/4$ inch, unless shown otherwise in the Contract Documents.

Make the saw cut as soon as the concrete has hardened enough so that no excess raveling or spalling occurs, but before any random cracks develop. The sequence of the sawing is at the Contractor's option, provided all sawing is completed before random cracking develops. Use suitable guide lines or devices to cut the joint straight and in the correct location.

(b) Cleaning Joints. Immediately clean freshly cut sawed joints by flushing with a jet of water under pressure and other necessary tools to remove the resulting slurry from the joint and immediate area. Repair curing membrane damaged during sawing and cleaning, as directed by the Engineer.

(c) Backer Rod. Install and maintain backer rod (of a size sufficient to prevent debris from entering the joint) in the joint. When major construction traffic is no longer driving on the pavement, and prior to opening to the public, remove the backer rod, and follow with an air blast to remove any debris.

(d) Repair of Joints. If the sawed joint is $\geq 1/4$ inch, seal the joint using Hot Applied Joint Sealing Compound, according to **subsections 501.4g.(7) thru (9)(b)**. Seal transverse joints the full width of pavement. Seal longitudinal joints the full length of the panel. If the joint can not be properly sealed, see **subsection 501.4k**.

501 - PORTLAND CEMENT CONCRETE PAVEMENT (QC/QA)

(e) Opening to Traffic. When no joints require sealing, disregard **subsection 501.4i.(3)(a)**, third bullet and **501.4i.(3)(b)**.

(f) Side Roads and Entrance Pavement. If the PCCP is designated with sawed (non-sealed joints), construct the side road and entrance pavement joints according to **subsection 501.4g.(10)**, unless otherwise specified in the Contract Documents.

(g) Curb and Gutter/Valley Gutter. Unless specified otherwise in the Contract Documents, if the PCCP is designated with sawed (non-sealed) joints, construct the curb and gutter/valley gutter joints according to **subsections 501.4g.(10)(a) thru (c)** with the following exception: saw to a depth a minimum of 1 ¼ inches below the surface of the gutter. If the curb and gutter is placed monolithically with the pavement, saw to the same depth as the pavement.

h. Hand Finishing. Hold hand finishing methods to a minimum. Generally, hand methods of placement and finishing will be permitted as follows:

- For pavement when a breakdown of some portion of the paving train occurs, making the hand finishing of that portion of the concrete already in place necessary.
- For pavement lanes that may be too narrow or a length too short to accommodate a full paving spread.
- For all irregular shaped areas.
- For special approach sections to bridges, widened portions at bridges, intersections and sections widened beyond traffic lanes.
- When the dimensions of the work make the use of a complete power operated paving impossible, or impracticable.

For uniform width areas or transition width areas using false forms, finish handwork with a mechanical finishing machine or approved vibrating screed, whenever possible.

Use spud hand vibrators on any area considered impracticable to vibrate with a vibrating screed. Approved metal or wood floats may be used if needed to help close an open or porous surface condition.

Continue the operation of consolidation and screeding or striking off the concrete until the concrete is uniformly consolidated and the surface is true to line, grade and cross-section.

After the pavement has been properly struck off, straightedge the pavement for trueness and finish it. Use a burlap drag to remove surface straightedge marks. The burlap drag may be pulled by hand, but the results shall be similar to that on the mainline pavement.

Manual methods may be used for texturing hand finished pavement areas. Where applicable, the tined texture applies. Use a metal comb with dimensions and spacing shown in **subsection 154.7c**. Obtain a finished textured surface similar to that produced mechanically.

On miscellaneous areas such as entrance pavement, median pavement and gore areas, texturing with the metal comb may be eliminated. Final finish may be attained by the use of a drag that consists of a seamless strip of damp burlap, cotton fabric or other suitable material capable of producing a uniform surface of gritty texture.

i. Protection and Curing of Concrete. Cure the pavement by using burlap, liquid membrane-forming compounds, white polyethylene sheeting, concrete curing blankets or reinforced white polyethylene sheeting. Failure to provide proper curing is cause for immediate suspension of the concreting operations.

(1) Burlap, Concrete Curing Blankets, White Polyethylene Sheeting and Reinforced White Polyethylene Sheeting. Place the curing material on the pavement immediately after the pavement has been finished, and the concrete has hardened sufficiently to avoid harmful marring of the surface, yet early enough to prevent undue loss of moisture from the concrete. If the pavement becomes dry before the curing material is placed, moisten the concrete with a fine spray of water. Dampen burlap and place on the surface. Place burlap-polyethylene blankets with the dampened burlap side down. Keep burlap damp throughout the entire curing period.

Lap adjacent units of curing materials approximately 18 inches. Upon removal of the forms, extend the material to completely cover the full depth of the exposed pavement.

Weigh the curing material down using continuous windrows of earth placed along the sides and edges of the pavement and transversely across the pavement on the laps to cause the material to remain in contact with the covered surface throughout the curing period. Other methods may be used with approval of the Engineer.

Walking on the pavement surface to place the curing material is prohibited. Walking on the curing material is prohibited until the pavement has cured sufficiently to prevent damage to the surface.

501 - PORTLAND CEMENT CONCRETE PAVEMENT (QC/QA)

Leave the curing material in place for a minimum of 4 days, unless otherwise directed by the Engineer. Immediately repair any tears or holes appearing in the material during the curing period, or replace it with material in good condition.

The material may be reused, provided it is kept serviceable by proper repairs, and if in the judgment of Engineer it will provide water retention during the curing period.

(2) Type 2 White Liquid Membrane-Forming Compound. After finishing operations have been completed and immediately after the free water has left the surface, completely coat and seal the surface of the slab with a uniform layer of compound. Apply the compound in 1 application at a minimum rate of 1 gallon per 150 square feet of surface. Thoroughly mix the compound at all times during usage. Do not dilute the compound. Daily provide the Inspector documentation of the quantity of curing compound used.

Protect the treated surface from injury a minimum of 4 days, unless otherwise directed by the Engineer. If the newly coated film is damaged in any way, apply a new coat of material to the affected areas equal in coverage to that specified for the original coat. A minimum of foot traffic will be permitted on the dried film as necessary to properly carry on the work, provided any damage to the film is immediately repaired by application of an additional coat of compound.

Immediately after the forms are removed (fixed form and slip form), coat the entire area of the sides of the slab with compound at the rate specified for the pavement surface, regardless of whether or not further concrete placement will be made against the pavement edge. Approved hand spray equipment will be permitted only for the application of compound on the sides of the slab, for repairing damaged areas and for hand finished areas. Repair any damaged areas caused by joint sawing.

(3) Opening to Traffic. No motorized traffic is allowed on the pavement until all of the following conditions are met.

(a) Construction Traffic Only.

- The flexural strength of the pavement shall meet or exceed 450 psi. Determine the flexural strength of the pavement by testing flexural strength specimens utilizing the third point loading method, or by use of a calibrated maturity meter.
- If flexural strength does not meet or exceed 450 psi, observe a 10 day curing period before allowing motorized traffic on the pavement. Provide a strength gain curve of concrete cured at 45°F to justify a curing period of less than 10 days.
- Provide protection to keep foreign material out of the unsealed joints by an approved method.

(b) All Traffic. In addition to **subsection 501.4i.(3)(a)**, seal the joints according to **subsection 501.4g.(9)**.

The Contractor may, at own expense, increase the cement content from the minimum shown in **SECTION 403** to accelerate the strength gain of the PCCP.

(4) Cold Weather Curing. Maintain the concrete pavement at a minimum temperature of 40°F, as measured along the surface of the concrete, for a minimum of 4 days after placing. When the ambient air temperature is expected to drop below 35°F anytime during the curing period, take precautions to maintain the concrete temperature. Keep a sufficient supply of approved moisture barrier material, other than liquid curing compound, and suitable blanketing material, such as straw, hay and burlap close by. Be prepared to cover the pavement with a moisture barrier and protect all pavement less than 4 days old with blanketing material. Remove, dispose of and replace concrete damaged by cold weather, as determined by the Engineer.

(5) Early Strength Concrete Curing. The curing period shall conform to the requirements specified for regular concrete pavement in **subsection 501.4.i**. Construct joints according to the manufacturer's recommendations for early strength concrete pavement.

j. Cold Weather Limitations. If concrete is placed in cold weather, comply with **SECTION 401**.

k. Repair of Defective Pavement Slabs. It is the responsibility of the Contractor to repair any spalled, cracked or broken panels as specified hereinafter at no cost to KDOT. Completely remove and replace pavement panels (area between contraction joint and contraction joint) containing both transverse and longitudinal cracks (separating the panel into 4 or more parts) through the full depth of the slab.

Properly seal the joints of the repaired or replaced panels.

(1) Repair of Spalls.

501 - PORTLAND CEMENT CONCRETE PAVEMENT (QC/QA)

- In no case shall an individual patch of a spall be less than 1 square foot with no dimension less than 1 foot.
- For spalls greater than $\frac{1}{4}$ inch and less than or equal to $\frac{1}{2}$ inch from edge of the original sawed joint, repair with hot pour.
- For spalls greater than $\frac{1}{2}$ inch and less than or equal to 1 inch from the edge of the original sawed joint, blast clean and repair with epoxy patch material.
- For spalls greater than 1 inch from the edge of original sawed joint, repair by making a saw cut a minimum of 1 inch outside the spalled area to a minimum depth of 2 inches. The interior angles formed by the intersection of adjacent sides of the patch shall be a minimum of 60° . When the spalled area abuts a joint, make the saw cut to a depth of 2 inches or $\frac{1}{6}$ the slab thickness, whichever is greater. Chip out the concrete between the saw cut and the joint or primary crack to solid concrete. Do not use chipping hammers greater than 15 pounds. Thoroughly clean all loose material from the formed cavity. Apply a coat of an approved concrete bonding epoxy to the dry, cleaned surface of all sides of the cavity, except the joint. Apply the epoxy by scrubbing the material into the surface with a stiff bristle brush. Place portland cement concrete, epoxy resin concrete or mortar, immediately following application of the epoxy, according to the manufacturer's recommendations. If the spalled area to be patched abuts a working joint, use an insert or other bond breaking medium during the repair work to maintain working joints. Remove and replace major honeycombed areas found after removal of the forms. Removed areas or sections so removed shall be a minimum of 6 feet in length if less than full width of the lane involved. When it is necessary to remove a section of pavement, also remove and replace any remaining portion of the slab adjacent to the joints that is less than 6 feet in length.

(2) Repair of Cracks in New Reinforced, Dowel Jointed PCCP.

(a) Transverse and Diagonal Cracks.

(i) Full Depth.

- When a single full-depth transverse crack falls within the middle $\frac{1}{3}$ of the panel, no corrective work will be required.
- Should a second full-depth crack develop within the middle $\frac{1}{3}$ of the panel, remove and replace the panel to the nearest planned contraction joint, eliminating both cracks. If the location of the mid-panel full-depth crack is within 6 feet of the boundaries of the area to be repaired, extend the area to be repaired to include the mid-panel crack.
- When any portion of a full-depth crack falls outside the middle $\frac{1}{3}$ of the panel, remove and replace the portion of panel between the contraction joint and the crack. Make 1 full-depth saw cut parallel to the contraction joint on the mid-panel side of the crack to be removed. Make another cut in the adjacent panel, parallel to the contraction joint, clear of the basket assembly, but not less than 6 feet from the first cut. Remove the cracked section and basket assembly. Drill holes in both sawed faces, and insert bars to make 2 contraction joints. Use dowels of the same size and spaced the same distance as those shown in the Contract Documents. Drill bar holes $\frac{1}{4}$ inch \pm 0.05 inch larger than the diameter of the bar and fill them with epoxy or grout and insert the new dowel. Support the free ends of the bars parallel to the pavement surface until the epoxy or grout has set, obtaining proper alignment of the bar. Apply grease or an approved bond breaker to the free ends.
- If the boundaries of consecutive areas to be repaired are less than 6 feet apart, also remove and replace the areas between the patches.
- Saw off the longitudinal joint tie bars at the longitudinal joint. Drill holes midway between the existing bars and insert tie bars to make a new tied longitudinal hinged joint. Use tie bars of the same size and spacing as those in the Contract Documents. Drill bar holes $\frac{1}{4}$ inch \pm 0.05 inch larger than the diameter of the bar and fill them with epoxy or grout and insert new tie bars.

(b) Longitudinal Cracks. When a single longitudinal crack falls within a panel, no corrective work will be required.

501 - PORTLAND CEMENT CONCRETE PAVEMENT (QC/QA)

When a second full-depth longitudinal crack falls within a panel, remove and replace the panel to the nearest planned contraction joint, eliminating both cracks.

(3) Repair of Cracks in both New Non-reinforced Dowel Jointed PCCP and Mainline Plain PCCP.

(a) Transverse and Diagonal Cracks.

(i) Full Depth.

- If a maximum of 4 panels per any lane mile has a crack, repair according to **SECTION 504 - DOWEL BAR RETROFIT-REPAIR**, or remove and replace the pavement.
- If 5 to 18 of the panels per any lane mile has a crack, repair according to **SECTION 504 - DOWEL BAR RETROFIT-REPAIR**. When 2 consecutive panels have a crack, remove and replace the panels from contraction joint to contraction joint.
- If more than 18 of the panels per any lane mile have a crack, remove and replace the pavement bounded by the cracks in that segment. Remove and replace until ¼ mile segment has less than 4 panels cracked, then repair or replace.

(ii) Partial Depth. If coring (at no additional cost to KDOT) verifies the transverse cracks are not full depth, repairs may be made by **SECTION 505 - TIE BAR INSERTION-REPAIR**.

(iii) When required or at the Contractor's option, remove and replace pavement panels containing any transverse or diagonal crack according to the following:

- Make a full-depth saw cut in the abutting panel nearest to the crack, parallel to the contraction joint, just clear of the basket assembly to allow the existing dowel basket assembly to be completely removed. Make a second saw cut parallel with the contraction joint on the opposite side of the crack away from the contraction joint. For plain PCCP, make the saw cut at the joint nearest to the crack. Make the second saw cut opposite the first cut a minimum of 6 feet from the first saw cut to include the crack. Remove the resulting area.
- The minimum longitudinal length of a patch is 6 feet.
- Do not permit a patch to fall within 6 feet of a contraction joint.
- The maximum distance between doweled/non-doweled contraction joints is 18 feet.
- Drill holes and insert dowel bars to make new contraction joints within the vertical faces of both newly created panel ends. Use dowels of the same size and spaced the same distance as shown in the Contract Documents. Drill bar holes ¼ inch ± 0.05 inch larger than the diameter of the bar and fill with epoxy or portland cement grout and insert the new dowel. Support the free ends of the bars until the epoxy or grout has set to obtain proper alignment of the bar. Apply grease or an approved bond breaker to the free ends. Do not use dowel bars in plain PCCP.
- Saw off the longitudinal joint tie bars at the longitudinal joint. Drill holes midway between the existing bars and insert tie bars to make a new tied longitudinal hinged joint. Do not place new tie bars within 12 inches of doweled joint. Use tie bars of the same size and spacing as those in the Contract Documents. Drill bar holes ¼ inch ± 0.05 inch larger than the diameter of the bar and fill them with epoxy or grout and insert new tie bars.

(b) Longitudinal Cracks. Repair or remove and replace pavement panels that contain a single longitudinal crack, according to the following:

- Repair longitudinal cracks that are within 3 inches of the planned longitudinal joint for their entire length with a partial depth patch as specified for spall in **subsection 501.4k.(1)**, except make the transverse dimension of the patch 6 inches and saw cuts to $D/3 \pm 1/4$ inch.
- For longitudinal cracks between 3 and 6 inches from the planned longitudinal joint, fill the entire planned longitudinal joint full depth with epoxy through the length of the longitudinal crack.
- Repair longitudinal cracks that are 6 inches or more from the planned longitudinal joint by removing and replacing pavement panels, or repair pavement by **SECTION 505 - TIE BAR INSERTION-REPAIR**.

501 - PORTLAND CEMENT CONCRETE PAVEMENT (QC/QA)

Remove and replace pavement panels that contain 2 or more longitudinal cracks.

(4) Repair of Cracks in Shoulder Plain PCCP.

(a) Transverse and Diagonal Cracks.

- When a single transverse crack falls within a panel and is within 3 feet of the transverse contraction joint, fill the contraction joint according to the Contract Documents and rout and seal the crack.
- When 2 or more transverse cracks fall within a panel, remove and replace the panels.

(b) Longitudinal Cracks.

- When a single longitudinal crack falls within a panel, repair pavement by **SECTION 505 - TIE BAR INSERTION-REPAIR**.
- When 2 or more longitudinal cracks fall within a panel, remove and replace the panels.

l. Protection of Pavement from Rain. Before placing PCCP, prepare and submit to the Engineer for approval, a Protection Plan to address the onset of rain during concrete placement. As a minimum, the plan shall include protective covering and side forms available at the project site at all times to protect the surfaces and edges of the newly placed concrete pavement. Polyethylene, burlap or other covering materials may be used. Side forms may be of wood or steel and shall have a depth a minimum of the thickness of the pavement. Specify the location of the storage site in order that a review of the protective materials may be conducted by the Engineer.

Include the type and amount of protective materials as well as the methods proposed to protect the pavement.

When rain appears imminent, stop all paving operations and initiate the Protection Plan. Extend the covering back to the point where the rain will not indent the surface. Exercise care to prevent unnecessary damage to the surface with the covering.

m. Pavement Smoothness. Evaluate pavement smoothness for pay according to **SECTION 503**.

501.5 MEASUREMENT AND PAYMENT

a. Plan Quantity Measurement. The quantities of concrete pavement for which payment will be made are the quantities shown in the Contract Documents for the traveled way lanes and the various paved approaches, exits and interchanges, provided the project is constructed essentially to details shown in the Contract Documents.

When the Contract Documents have been altered, or when a disagreement exists between the Contractor and the Engineer as to the accuracy of the Contract Document quantities in any location or the entire project, either party has the right to request and cause the quantities involved to be measured according to **subsection 501.5b**.

b. Measured Quantities. The quantity to be paid for under this item will be the number of square yards of concrete pavement as measured in-place. The width for measurement will be the width of the pavement shown on the typical cross-section of the Contract Documents, additional widening where added, or as otherwise directed in writing by the Engineer. The length will be measured horizontally along the centerline of each roadway or ramp.

c. Excavation Included in Contract. On projects where the grading and the pavement or base construction is included in the same contract, the Engineer will not measure additional excavation required to obtain the specified subgrade elevation.

d. Sawing and Sealing Joints. The Engineer will not measure this work for separate payment. All costs of complying with the requirements specified herein are included in the contract price for the concrete pavement in which the joints are located.

e. Quality Control Testing. The Engineer will measure the Contractor's quality control testing by the square yard of PCCP placed on the project. The Engineer will measure each concrete core when the results from the core information (required for disputed tests) increases payment to the Contractor. All other cores taken as required by this specification are subsidiary to this item.

501 - PORTLAND CEMENT CONCRETE PAVEMENT (QC/QA)

f. Water. The Engineer will not measure water used in dust control on haul roads, around plant installations, etc.

g. Pavement Thickness and Compressive Strength Determination.

(1) General. Make the required corrections for pavement smoothness before making the pavement thickness determinations. Determination of pavement thickness and pavement compressive strength for the purpose of establishing pay adjustments will be based on test results from cores taken from each lot of pavement.

- For mainline pavement, pay adjustments will be made for both thickness and compressive strength.
- For acceleration lane, deceleration lane, frontage road, side road and ramp pavement, pay adjustments will be made for thickness, but not compressive strength, unless the Contract Documents specifically require compressive strength pay adjustments.
- For gore areas, bridge approach slabs, intersection curb returns, entrances, shoulders, medians and widenings, pay adjustments will not be made for thickness or compressive strength, and pavement cores will not be required.

Where coring is not required, verify that the thickness of the pavement meets or exceeds the Contract Document requirements by use of stringline, survey or other suitable depth measurement. For pavement types not cored for strength, use only concrete mix designs approved for use in the mainline pavement. The Engineer will observe and document the Contractor’s measurement or other means of ensuring the appropriate thickness of the plastic concrete, and the Engineer will verify that only approved mixes are used. Prior to placing any pavement not specifically defined above, reach an agreement with the Engineer as to the applicability of pay factors.

(2) Lots and Sublots Defined.

(a) For mainline and other pavement subject to coring for pay adjustments for both thickness and strength, a lot is defined as the surface area of mainline lane placed in a single day. Normally, divide a lot representing a day’s production into 5 sublots of approximately equal surface area.

For high daily production rates, rates exceeding 6000 square yards per day, the Contractor may choose to divide the day’s production into 2 approximately equal lots consisting of 5 sublots each. Prior to taking any core samples, notify the Engineer of the decision to divide a day’s production into 2 equal lots. For low daily production rates (and not in an urban PCCP environment), the Contractor may choose to divide the lot into a lesser number of sublots as shown in **TABLE 501-1**. When daily production rates are less than 1000 square yards, and not in an urban PCCP environment, combine the day’s production with the next day’s production to form a lot. When a day’s production involves less than 1000 square yards while completing a particular mix design or project, combine with the previous day’s production and treat as a single lot.

For low daily production rates less than 1000 square yards in an urban PCCP environment, consider each day’s production as a separate lot. KDOT’s representative will core (or have cored) a minimum of two randomly-determined sublots per day; one in the morning and one in the afternoon. Each randomly-determined location will be cored for both strength and thickness, and results inserted into the “Urban PCCP” worksheet for pay adjustment.

TABLE 501-1: PCCP SUBLLOT BREAKDOWN	
Daily Production Rate in square yards	Number of Sublots
Under 1000 (Urban)	2
1001 – 2000	3
2001 – 4000	4
4001 or more	5

(b) For pavement that is to be cored for thickness only, group each continuous section of acceleration lane, deceleration lane, side road, frontage road and ramp pavement of equal plan thickness and contract unit price into a lot a maximum of 5000 square yards in area. Divide each lot into a minimum of 3 sublots of approximately equal surface area. Sublots shall be a maximum

501 - PORTLAND CEMENT CONCRETE PAVEMENT (QC/QA)

of 1000 square yards in size. Sample each subplot in a manner so that each square yard of pavement has a chance of being randomly selected for coring.

(3) Coring. The Engineer reserves the right to generate the random locations. If KDOT plans to generate the random locations, the Contractor will be notified before taking cores for thickness determination.

(a) For mainline and other pavement subject to coring for pay adjustments for both thickness and strength, take 1 core sample having a minimum diameter of 4 inches from a randomly selected site within each subplot. The Contractor has the option of taking an additional core sample having a minimum diameter of 2 inches from a randomly selected site within each subplot for the purpose of making an early determination of the pavement thickness only. Select sites according to the approved QCP. Additionally, take 1 companion core having a minimum diameter of 4 inches per each lot at a randomly selected site as designated by the Engineer. Repair all core holes in a manner approved by the Engineer. Perform all coring for the purpose of determining strength a minimum of 21 days after the pavement has been placed, and in time to determine 28-day compressive strengths. Coring prior to the 21-day minimum will be permitted with approval of the Engineer, when opening to early traffic is desired. If the companion cores will be measured and tested by the MRC, the Engineer will deliver the companion cores to the MRC within 25 days after the pavement has been placed. No initial QC compressive strength data will be accepted for concrete paving that is more than 28 days of age, unless approved by the Engineer.

(b) For all other PCCP subject to coring for pay adjustment, thickness only, define the lots prior to placement with the Engineer's approval.

After placement, randomly select each subplot location. Take 1 core sample having a minimum diameter of 2 inches. Repair all core holes in a manner approved by the Engineer. Coring may be performed at any time after all pavement in the lot has been placed.

(4) Mark each core with the lot and subplot number from which it was selected. Transport the cores to the laboratory as soon as possible and perform the thickness determination. Take 3 caliper measurements on each core at approximately 120° apart. Record these 3 measurements to the nearest 0.01 inch, and average them to represent the height of that core.

Do not test 2-inch core samples for compressive strength. Do not measure 4-inch cores for pavement thickness determination if a separate 2-inch core sample was taken in a subplot for that purpose.

The measured core height will represent the constructed pavement thickness for each pavement subplot. The Engineer will witness thickness determinations and initial the Contractor's documentation.

Moist cure the 4-inch cores to be tested for compressive strength as required in KT-49, until they are tested. Perform the 28-day compressive strength testing on the entire length of the core after squaring the ends according to KT-49. The compression machine shall be capable of testing cores up to and including 12 inches in length. Remove only the excess length that exceeds compression machine capabilities from the bottom of the cores. Determine length and diameter to the nearest 0.01 inch. Determine the length/diameter ratio (LD), and round the result to the nearest hundredth using the following formula:

$$LD = \text{Length} / \text{Diameter}$$

After performing the strength test, correct the compressive strength using a correction factor determined by using the appropriate formula in **TABLE 501-2**.

TABLE 501-2: COMPRESSIVE STRENGTH CORRECTION FACTOR FORMULAS	
LD	Correction Factor
LD < 2	$\frac{100}{95 + 0.2(1/LD) + 19.5(1/LD)^2}$
LD = 2	1.000
LD > 2	$\frac{100}{110 - 5(LD)}$

501 - PORTLAND CEMENT CONCRETE PAVEMENT (QC/QA)

The compressive strength correction factor may also be obtained by using **TABLE 501-3**. If a discrepancy should arise due to rounding numbers or the appropriate value is not shown in the table, the value determined by the above formulas shall govern.

TABLE 501-3: COMPRESSIVE STRENGTH CORRECTION FACTOR			
LD	Compressive Strength Correction Factor	LD	Compressive Strength Correction Factor
1.00	0.872	2.60	1.031
1.10	0.898	2.70	1.036
1.20	0.920	2.80	1.042
1.30	0.937	2.90	1.047
1.40	0.952	3.00	1.053
1.50	0.963	3.10	1.058
1.60	0.973	3.20	1.064
1.70	0.982	3.30	1.070
1.80	0.989	3.40	1.075
1.90	0.995	3.50	1.081
2.00	1.000	3.60	1.087
2.10	1.005	3.70	1.093
2.20	1.010	3.80	1.099
2.30	1.015	3.90	1.105
2.40	1.020	4.00	1.111
2.50	1.026		

Correct the compressive strength determined during testing by multiplying that amount by the compressive strength correction factor.

The Engineer will witness all compressive strength tests for each subplot and initial the Contractor's documentation.

Companion cores will be measured and tested at KDOT's laboratory to verify the Contractor's test results. Supply 28-day compressive strength data to KDOT. Acceptance of the pavement and pay adjustments will be on the basis of Contractor quality control test results on random samples taken from a lot, provided the statistical comparison is favorable.

KDOT will routinely compare the variances (F-test) and the means (t-test) of the verification test results with the quality control test results for thickness and compressive strength as appropriate using a KDOT spreadsheet. The F and t-tests, along with the KDOT Spreadsheet used to compare the Contractor's Quality Control (QC) results and KDOT's verification (QA) results, are described in Section 5.2.6-Comparison of Quality Control and Verification Tests, Part V. If KDOT verification test results do not show favorable comparison with the Contractor's quality control test results, KDOT verification test results will be used for material acceptance, material rejection and the determination of any pay adjustment for thickness and compressive strength. Follow the requirements stated in **subsection 501.5h.(6)** for failing t-tests. If the Contractor disputes KDOT's verification test results, and the Contractor and the Engineer cannot mutually agree on the use of KDOT test results to determine pay adjustments, the test results for the lot in question will be voided. In such case, new cores to represent each subplot will be taken on a 2-for-1 frequency, tested in the presence of the Engineer, and a new pay factor will be calculated using the KDOT spreadsheet. These cores shall be obtained in time to determine the 35-day compressive strengths unless approved by the Engineer. If the new pay factor results in the same or less pay due the Contractor than the voided pay factor, no payment will be made for the additional coring. If the new pay factor results in greater payment to the Contractor, KDOT will pay for each additional core at the contract set unit price.

(5) When the measurement of any core is deficient by more than 1 inch from plan thickness or has a 28-day compressive strength less than 2900 psi, take exploratory cores at a minimum of 10 foot intervals along a line passing through the deficient core and parallel to the centerline of the pavement unit. Continue along this line until an exploratory core taken in each direction is not deficient in length by more than 1 inch, or the compressive strength is a minimum of 2900 psi, depending on which case is being investigated. Exploratory cores will be used only to determine the length of pavement in a unit that is to be removed and replaced as provided below. Discard the original core representing the subplot. Randomly select another core (outside the defective area if left in place) to

501 - PORTLAND CEMENT CONCRETE PAVEMENT (QC/QA)

represent the remainder of the subplot and use to compute the pay factor for the lot. All exploratory cores will be obtained in time to determine the compressive strengths within 35 days from the time the pavement was placed, unless approved by the Engineer. Obtain all cores representing the remainder of the subplot and used to compute the pay factor for the lot in time to determine the 35-day compressive strengths, unless approved by the Engineer.

When the Engineer determines that deficient pavement must be removed, the Contractor is required to remove the deficient areas and replace them with pavement of satisfactory quality, strength and thickness. When it is necessary to remove and replace a length of pavement and one end of the deficient pavement is less than 10 feet from an expansion, contraction or construction joint, remove and replace the entire pavement up to the joint. Remove the area so that new joints are a minimum of 10 feet apart. No additional compensation for materials or labor involved in the removal or replacement of the deficient concrete pavement will be made.

(6) For subplot thickness results greater than 1 inch more than design thickness, change the subplot thickness result to 1 inch more than the design thickness. The KDOT spreadsheet will calculate a new lot mean and sample standard deviation based on the corrected value.

h. Pay Adjustments for Mainline and Other Specified Pavement.

(1) General. A single combined pay adjustment for thickness and compressive strength will be made on a lot-by-lot basis and will be based on Contractor quality control test results on all quality control samples representing the lot of the completed pavement provided the statistical check is favorable. Otherwise follow **subsection 501.5g.(4)**. Compute the combined pay factor (P) (positive or negative) as shown in Equation 1.

$$\text{Combined Pay Adjustment} = P \times (\text{the number of square yards included in the lot}) \times (\text{the contract unit price per square yard})$$

The thickness component of the combined pay factor will be based on values determined by using the difference between plan thickness and the measured core sample thickness, and the lower specification limit (LSL). LSL is defined as 0.2 inch less than plan thickness. The compressive strength component of P will be based on the corrected measured compressive strength of core samples taken from the pavement (see **subsection 501.5g.(4)** for LD correction). The pay adjustment amount will be added or subtracted as Concrete Pavement Composite Pay Adjustment on the pay estimate.

Note 1: A lot will normally be comprised of the results of 5 tests performed on a day's placement of a given pavement type. Lot and subplot size is defined in **subsection 501.5g.(2)**.

Note 2: The sample standard deviation (S) will be computed as shown in Section 5.2.1-Statistics, Part V.

(2) Thickness Quality Index (Q_T) Computation. Calculate Q_T for each lot as shown in 5.2.1, Part V, using the following definitions, and round to hundredths.

Where: \bar{X} is the average measured core length of all QC samples representing a lot, rounded to the nearest 0.1 inch.

LSL is the lower specification limit for thickness, and equals plan thickness minus 0.2 inch.

S is the sample standard deviation of the measured core lengths of all QC samples representing a lot, rounded to the nearest hundredth.

(3) Compressive Strength Quality Index (Q_S) Computation. Calculate Q_S for each lot as shown in Section 5.2.1-Statistics, Part V, using the following definitions, and round to the nearest 0.1 inch.

Where: \bar{X} is the average measured compressive strength of all QC core samples representing a lot, rounded to 1 psi.

LSL is the lower specification limit for compressive strength and is defined as 3900 psi.

S is the sample standard deviation of the compressive strength of all QC samples representing a lot, rounded to the hundredth.

(4) Determination of the Percent within Limits Values. First, use the computed Q_T to determine the thickness percent within limits value (PWL_T) by locating Q_T in the left column of the Percent Within Limits (PWL) Table in Section 5.2.1-Statistics, Part V. Select the appropriate (PWL_T) by moving across the selected Q row to the

501 - PORTLAND CEMENT CONCRETE PAVEMENT (QC/QA)

column representing the number of samples in the lot. Next, follow the same procedure using the computed Q_S value to select the appropriate compressive strength percent within limits value (PWL_S).

If either computed Q_T or Q_S is a negative value (\bar{X} is less than LSL), the Engineer will determine if the material in the lot may remain in place. If the material is left in place, a value of 50.00 is assigned as PWL_T or PWL_S , respectively. If both Q_T and Q_S are negative, assign a value of 50.00 for each PWL component.

If either Q_T or Q_S is greater than the largest Q shown in the table, a value of 100.00 is assigned as PWL_T or PWL_S , respectively, or for both should Q_T and Q_S both exceed the values shown in the table.

(5) Computation of Combined Pay Factor. Compute P for thickness and compressive strength using Equation 1 and round to nearest hundredth.

$$\text{Equation 1: } P = \left(\frac{(PWL_T + PWL_S) * 0.60}{200} \right) - 0.54$$

(6) Failing t-test. If the t-test fails, KDOT's test result will be used to calculate that particular pay factor for the lot. Follow the procedures given in **subsection 501.5h.(4)** to determine the pay factor or disposition of the lot.

Use the following values to determine Q_T or Q_S :

Where: \bar{X} will be KDOT's test result for the lot.

N is equal to the number of Contractor's sublots.

S will be $\frac{3}{8}$ inch for thickness and 500 psi for strength.

LSL will be as stated in **501.5h.(2)** for determining Q_T , and **501.5h.(3)** for determining Q_S .

i. Pay Adjustments for Pavements Cored for Thickness Only.

(1) General. A single pay adjustment for thickness only will be made on a lot-by-lot basis. It will be based on Contractor quality control test results on all quality control thickness samples representing the lot of the completed pavement provided the statistical check is favorable. Otherwise, follow **subsection 501.5h.(4)**. Compute the thickness pay factor (P_T) (positive or negative) as shown in Equation 2.

Thickness Pay Adjustment = P_T x (the number of square yards included in the lot) x (the contract unit price per square yard)

The thickness component will be based on values determined by using the difference between plan thickness and the measured core sample thickness, and the lower specification limit (LSL). The pay adjustment amount will be added or subtracted as Concrete Pavement Composite Pay Adjustment on the pay estimate.

Note: A lot will normally be comprised of the results of tests performed on all sublots within a given pavement type. Lot and subplot size for pavements cored for thickness only is defined in **subsection 501.5g.(4)**.

(2) Determine PWL_T as shown in **subsection 501.5h.(4)**.

(3) Computation of Thickness Pay Factor. Compute the pay factor for thickness using Equation 2 and round to nearest hundredth.

$$\text{Equation 2: } P_T = \left(\frac{(PWL_T) * 0.30}{100} \right) - 0.27$$

(4) Failing t-test. If the t-test fails, KDOT's test result will be used to calculate that particular pay factor for the lot. Follow the procedures given in **subsection 501.5h.(4)** to determine the pay factor or disposition of the lot.

Use the following values to determine Q_T :

Where: \bar{X} will be KDOT's test result for the lot.

N is equal to the number of Contractor's sublots.

S will be $\frac{3}{8}$ inch for thickness.

LSL will be as stated in **501.5 i.(2)**.

501 - PORTLAND CEMENT CONCRETE PAVEMENT (QC/QA)

j. Pay Adjustments for Urban PCCP Environment.

(1) General. A single pay adjustment will be made on a subplot-by-subplot basis. The adjustment will be based on a single randomly-selected (by KDOT) core for both strength and thickness. Compute the pay factor (P_U) (incentive or disincentive) as shown in **Equation 3**.

The thickness component will be based on values determined by using the difference between plan thickness and the measured core sample thickness. When the measured core sample thickness is greater than the plan thickness, the “ Δ thickness” of **Equation 3** is positive. When the core thickness is less than the plan thickness, the “ Δ thickness” is negative. The compressive strength component will be based on values determined by breaking the core. Pay adjustment amount will be added or subtracted on the pay estimate. Remove and replace when values are less than those stipulated in **subsection 501.5g.(5)**. Maximum individual or combined pay adjustment is 103%.

(2) Computation of Urban PCCP Pay Factor. Compute the pay factor for thickness and strength using **Equation 3** and round to nearest hundredth.

Equation 3: $P_U = (P_{UC} + P_{UT})/2$

Where:

$P_{UC} = 0.0001 * (\text{strength}) + 0.59$; where strength is measured to the nearest 1 psi.

$P_{UT} = 0.15 * (\Delta \text{ thickness}) + 1.00$; where Δ thickness is measured to the nearest 0.01 inch from plan thickness.

(3) Computation of Urban PCCP Pay Adjustment. Compute the subplot pay adjustment using **Equation 4**.

Equation 4: Urban PCCP Pay Adjustment = $(P_U - 1) \times$ (the number of square yards included in the subplot) \times (the contract unit price per square yard)

This adjustment will be paid for under the bid item Concrete Pavement Composite Pay Adjustment.

k. Computations and Rounding. KDOT will use a MICROSOFT EXCEL spreadsheet program to calculate pay adjustments for thickness and compressive strength and to compare the Contractor’s QC and KDOT’s verification test results. KDOT will provide a copy of this program to the Contractor, when requested. Additional information on the program may be obtained from the Bureau of Construction and Materials. It is the Contractor’s responsibility to obtain the software required to run this program.

Values computed using equations referenced in this specification may vary slightly from the spreadsheet values due to rounding of numbers. In such cases the numbers computed by the spreadsheet take precedence.

l. General Payment. Payment for "Concrete Pavement", "Early Strength Concrete Pavement" and "Quality Control Testing" with pay adjustments as specified above is full compensation for the work specified.

Payment for "Concrete Core (Set Price)" at the contract set unit price will be paid when the results from the core information (required for disputed tests) increases payment to the Contractor.

In the event of overruns or underruns of the Contractor quality control testing, the Engineer will not adjust the contract unit price.

Pay adjustments for thickness-only and pay adjustments for thickness and strength combined will use the bid item "Concrete Pavement Composite Pay Adjustment", and will be shown as an added item to the contract.

1105 - AGGREGATES FOR CEMENT TREATED BASES

SECTION 1105

AGGREGATES FOR CEMENT TREATED BASES

1105.1 DESCRIPTION

This specification covers aggregate for the construction of fly ash and portland cement treated base.

1105.2 REQUIREMENTS

a. Composition. Provide singly or in combination, crushed limestone, crushed dolomite, crushed portland cement concrete pavement (PCCP) reclaimed from the project site and sand or sand-gravel produced from a naturally occurring alluvial deposit.

b. Quality¹. Provide individual aggregates that comply with the following:
Crushed Limestone and Dolomite.

- Soundness², minimum (KTMR-21) 0.85
- Wear³, maximum (AASHTO T 96) 50%

Reclaimed crushed PCCP.

- Soundness², minimum (KTMR-21) 0.85
- Wear³, maximum (AASHTO T 96) 60%

Sand or Sand Gravel.

- Soundness², minimum (KTMR-21) 0.85
- Wear³, maximum (AASHTO T 96)..... 50%

¹ Crushed aggregates with less than 10% material retained on the No. 4 sieve (excluding mineral filler supplements) must be produced from a source complying with the official quality requirements of this Section prior to crushing.

² The above requirements for soundness do not apply for aggregates having less than 10% material retained on the No. 4 sieve.

³ The above requirements for wear do not apply to aggregates having less than 10% material retained on the No. 8 sieve.

c. Product Control.

(1) Size Requirements. Develop a single point aggregate gradation and establish a plus and minus tolerance for each sieve specified in **TABLE 1105-1**. The established tolerances will be applied to the designated single point gradation for the purposes of establishing a gradation band for field acceptance testing. Perform sieve analyses of the aggregates and chart the results. Suspend production of materials when any test result on any sieve falls outside the gradation band.

TABLE 1105-1: GRADATION OF AGGREGATES FOR CEMENT TREATED BASES (PERCENT RETAINED)						
Sieve size	1 ½"	¾"	No. 4	No. 8	No. 40	No. 200
Single point	*	*	*	*	*	*
Tolerance	*	+/-*	+/-*	+/-*	+/-*	+/-*

* These values to be established by the Contractor

(2) Deleterious Substances. Provide aggregates that are free from grass, weeds, roots, sticks, and other undesirable foreign matter.

d. Stockpiling. Stockpile and handle aggregates in such a manner to prevent detrimental degradation and segregation, the incorporation of appreciable amounts of foreign material, and the intermingling of stockpiled materials.

1105 - AGGREGATES FOR CEMENT TREATED BASES

1105.3 TEST METHODS

Test aggregates according to the applicable provisions of **SECTION 1115**.

1105.4 PREQUALIFICATION

Prequalify aggregate sources according to **subsection 1101.4**.

1105.5 BASIS OF ACCEPTANCE

Aggregates covered by this subsection are accepted based on the procedures described in **subsection 1101.5**.

**KANSAS DEPARTMENT OF TRANSPORTATION
SPECIAL PROVISION TO THE
STANDARD SPECIFICATIONS, 2015 EDITION**

SECTION 1116

AGGREGATES FOR ON GRADE CONCRETE

1116.1 DESCRIPTION

This specification is for coarse aggregates, intermediate aggregates, fine aggregates, mixed aggregates (coarse, intermediate and fine material) and miscellaneous aggregates for use in construction of concrete placed on grade.

For Intermediate Aggregates and Mixed Aggregates, consider any aggregate with 30% or more retained on the No. 8 sieve to be Coarse Aggregate.

1116.2 REQUIREMENTS

a. Quality of Individual Aggregates.

(1) Provide aggregate for concrete that complies with the following requirements. Crushed aggregates with less than 20% material retained on the 3/8" sieve must be produced from a source complying with these requirements prior to crushing. Fine Aggregates for Concrete have additional Quality Requirements stated in subsection 1116.2e.(2).

Soundness by Freeze/Thaw (min.) (KTMR-21)*	0.90
Wear Grading B (max.)(AASHTO T 96)**	50%
Additional Requirements:***	
Modified Soundness by Freeze/Thaw (min.) (KTMR-21)	0.90
Relative Dynamic Modulus of Elasticity, minimum (KTMR-22 @ 660 F/T cycles) ...	95
Expansion, maximum (KTMR-22 @ 660 F/T cycles)	0.025%
* Soundness (KTMR-21) requirements do not apply to aggregates having less than 10% material retained on the No. 4 sieve.	
** Wear (AASHTO T 96) requirements do not apply to aggregates having less than 10% retained on the No. 8 sieve.	
***The additional requirements do not apply for uncrushed sand-gravel aggregates having less than 5% material retained on the 1/2" sieve.	

(2) All predominately siliceous aggregate must comply with the Wetting & Drying Test requirements, or be used with a Coarse Aggregate Sweetener, or will require Supplemental Cementitious Materials (SCM) to prevent Alkali Silica Reactions (ASR). Refer to TABLE 401-4 to determine the need for ASTM C 1567 Testing. When required, provide the results of mortar expansion tests of ASTM C 1567 using the project's mix design concrete materials at their designated percentages. Provide a mix with a maximum expansion of 0.10% at 16 days after casting. Provide the results to the Engineer at least 15 days before placement of concrete on the project.

Wetting & Drying Test of Siliceous Aggregate for Concrete (KTMR-23)	
Concrete Modulus of Rupture:	
• At 60 days, minimum.....	550 psi
• At 365 days, minimum.....	550 psi
Expansion:	
• At 180 days, maximum	0.050%
• At 365 days, maximum	0.070%

Aggregates produced from the following general areas are exempt from the Wetting and Drying Test:

- Blue River Drainage Area.
- The Arkansas River from Sterling, west to the Colorado state line.

- The Neosho River from Emporia to the Oklahoma state line.

(3) Coarse Aggregate Sweetener. Types and proportions of aggregate sweeteners to be used with Mixed Aggregates are listed in **TABLE 1116-1**.

TABLE 1116-1: COARSE AGGREGATE SWEETENER	
Type of Coarse Aggregate Sweetener	Proportion Required by Percent Weight
Crushed Sandstone*	40 (minimum)
Crushed Limestone or Dolomite*	40 (minimum)
Siliceous Aggregates meeting subsection 1116.2a.(2)	40 (minimum)
Siliceous Aggregates not meeting subsection 1116.2a.(2) **	30 (maximum)

*Waive the minimum portion of Coarse Aggregate Sweetener for all intermediate and fine aggregates that comply with the wetting and drying requirements for Siliceous Aggregates. In this case, combine the intermediate, fine and coarse aggregate sweetener in proportions required to comply with **subsection 1116.2a.(2)**

**To be used only with intermediate and fine aggregates that comply with the wetting and drying requirements of Siliceous Aggregates unless a Supplemental Cementitious Material is utilized.

(4) Deleterious Substances. Maximum allowed deleterious substances by weight are:

- Clay lumps and friable particles (KT-7) 1.0%
- Coal (AASHTO T 113)..... 0.5%
- Shale or Shale-like material (KT-8)..... 0.5%
- Sticks (wet) (KT-35)..... 0.1%
- Sum of all deleterious 1.5%

b. Mixed Aggregates

(1) Composition. Provide coarse, intermediate, and fine aggregates in a combination necessary to meet **subsection 1116.2b.(2)**. Use a proven optimization method such as ACI 302.1 or other method approved by the Engineer. Aggregates may be from a single source or combination of sources.

(2) Product Control.

(a) Gradations such as those shown in **TABLE 1116-2** have proven satisfactory in reducing water demand while providing good workability. Adjust mixture proportions whenever individual aggregate grading varies during the course of the work. Use the gradations shown in **TABLE 1116-2**, or other gradation approved by the Engineer.

Optimization is not required for concrete for patching pavements more than 10 years old, or Commercial Grade Concrete. The Engineer may waive the optimization requirements if the concrete meets all the requirements of **DIVISION 400** and/or **DIVISION 500**.

Follow these guidelines:

1. Do not permit the percent retained on two adjacent sieve sizes to fall below 4%;
2. Do not allow the percent retained on three adjacent sieve sizes to fall below 8%; and
3. When the percent retained on each of two adjacent sieve sizes is less than 8%, the total percent retained on either of these sieves and the adjacent outside sieve should be at least 13%.
 (for example, if both the No. 4 and No. 8 sieves have 6% retained on each, then:
 1) the total retained on the 3/8 in. and No. 4 sieves should be at least 13%, and
 2) the total retained on the No. 8 and No. 16 sieves should be at least 13%.)

TABLE 1116-2: ALLOWABLE GRADING FOR MIXED AGGREGATES FOR CONCRETE													
Type	Usage	Percent Retained - Square Mesh Sieves											
		1 1/2"	1"	3/4"	1/2"	3/8"	No. 4	No. 8	No. 16	No. 30	No. 50	No. 100	No. 200
MA-3	Optimized All Concrete		0	2-12	Note ¹	Note ¹	Note ¹	Note ¹	Note ²	Note ²	Note ²	95-100 ⁴	98-100 ⁵
MA-4	Optimized All Concrete ³	0	2-12	Note ¹	Note ¹	Note ¹	Note ¹	Note ¹	Note ²	Note ²	Note ²	95-100 ⁴	98-100 ⁵
MA-5	Optimized All Concrete		0	2-12	8 min	22-34		55-65		75 min		95-100	98-100
MA-7	Contractor Design KDOT Approved	Proposed Grading that does not correspond to other limits in this table but meet the requirements for concrete in DIVISION 400 and/or DIVISION 500.											98-100

¹ Retain a maximum of 22% and a minimum of 6% of the material on each individual sieve.

² Retain a maximum of 15% and a minimum of 6% of the material on each individual sieve.

³ Maximum top size of Limestone is 3/4".

⁴ Retain a maximum of 7% on the No. 100 sieve

⁵ Retain a maximum of 2% on the No. 200 sieve

- (b) Optimization Requirements for all Gradations, except MA-7.
- Actual Workability must be within ± 5 of Target Workability.

Where: W_A = Actual Workability
 W_T = Target Workability
 CF = Coarseness Factor

1. Determine the Grading according to KT-2
2. Calculate the Coarseness Factor (CF) to the nearest whole number.

$$CF = \frac{+3/8'' \text{ Material \% Retained}}{+ \# 8 \text{ Material \% Retained}} \times 100$$

3. Calculate the Actual Workability (W_A) to the nearest whole number as the percent material passing the #8 sieve.

$$W_A = 100 - \% \text{ retained on \#8 sieve}$$

4. Calculate the Target Workability (W_T) to the nearest whole number where
 For 517 lbs cement per cubic yard of concrete

$$W_T = 46.14 - (CF/6)$$

For each additional 1 lb of cement per cubic yard, subtract 2.5/94 from the Target Workability.

Maintain an Actual Workability within ± 5 of the Target Workability for combined aggregates.

- (c) Deleterious Substances. **Subsection 1116.2a.(4)**, as applicable.
- (d) Uniformity of Supply. Designate or determine the fineness modulus (grading factor) for each aggregate according to the procedure listed in Section 5.10.5-Fineness Modulus of Aggregates (Gradation Factor) of Part V before delivery, or from the first 10 samples tested and accepted. Provide aggregate that is within ±0.20 of the average fineness modulus.

Provide a single point grading for the combined aggregates along with a plus/minus tolerance for each sieve. Use plus/minus tolerances to perform quality control checks and by the Engineer to perform aggregate grading verification testing. The tests may be performed on the combined materials or on individual aggregates, and then theoretically combined to determine compliance.

(3) Handling of All Aggregates.

- (a) Segregation. Before acceptance testing, remix all aggregate segregated by transit or stockpiling.
- (b) Stockpiling.
 - Maintain separation between aggregates from different sources, with different gradings or with a significantly different specific gravity.
 - Transport aggregate in a manner that promotes uniform grading.
 - Do not use aggregates that have become mixed with earth or foreign material.
 - Stockpile or bin all washed aggregate produced or handled by hydraulic methods for 12 hours (minimum) before batching. Rail shipment exceeding 12 hours is acceptable for binning provided the car bodies permit free drainage.
 - Provide additional stockpiling or binning in cases of high or non-uniform moisture.
 - Stockpile accepted aggregates in layers 3 to 5 feet thick. Berm each layer so that aggregate do not “cone” down into lower layers.

c. Coarse Aggregates for Concrete.

(1) Composition. Provide coarse aggregate that is crushed gravel or crushed stone meeting the quality requirements of **subsection 1116.2a**. Consider limestone, calcite cemented sandstone, rhyolite, quartzite, basalt and granite as crushed stone.

Mixtures utilizing siliceous aggregate not meeting **subsection 1116.2a.(2)** may require supplemental cementitious materials to prevent Alkali Silica Reactions. Provide the results of mortar expansion tests of ASTM C 1567 using the project’s mix design concrete materials at their designated percentages. Provide a mix with a maximum expansion of 0.10% at 16 days after casting. Provide the results to the Engineer at least 15 days before placement of concrete on the project.

(2) Product Control. Use gradations such as those in **TABLE 1116-3** which have been shown to work in Optimized Mixed Aggregates, or some other gradation approved by the Engineer that will provide a combined aggregate gradation meeting **subsection 1116.2b**.

(3) Deleterious Substances. **Subsection 1116.2a.(4)**, as applicable.

TABLE 1116-3: GRADING REQUIREMENTS FOR COARSE AGGREGATES									
Type	Composition	Percent Retained - Square Mesh Sieves							
		1 ½"	1"	¾"	½"	3/8"	No. 4	No. 8	No. 30
CPA-1	Crushed Gravel or Crushed Stone	0	0-10	14-35	-	50-75	-	95-100	-
CPA-3	Crushed Gravel or Crushed Stone	-	-	0	0-35	30-70	75-100	95-100	-
CPA-4	Crushed Gravel or Crushed Stone	-	0	0-20	-	-	-	95-100	-

d. Intermediate Aggregate for Concrete.

(1) Composition. Provide intermediate aggregate for mixed aggregates (IMA) that is crushed stone, natural occurring sand, or manufactured sand meeting the quality requirements of **subsection 1116.2a**.

(2) Product Control. Provide IMA grading when necessary to provide a combined aggregate gradation meeting **subsection 1116.2b**.

(3) Deleterious Substances. **Subsection 1116.2a.(4)**, as applicable.

(4) Organic Impurities (AASHTO T21). The color of the supernatant liquid is equal to or lighter than the referenced standard solution.

e. Fine Aggregates for Concrete.

(1) Composition.

- (a) Type FA-A. Provide either singly or in combination natural occurring sand resulting from the disintegration of siliceous or calcareous rock, or manufactured sand produced by crushing predominately siliceous materials meeting the quality requirements of **subsection 1116.2a**. and **subsection 1116.2e.(2)**.

(2) Additional Quality Requirements.

(a) Mortar strength and Organic Impurities. If the DME determines it is necessary, because of unknown characteristics of new sources or changes in existing sources, provide fine aggregates that comply with the following:

- Mortar Strength (KTMR-26). Compressive strength when combined with Type III (high early strength) cement:
 - At age 24 hours, minimum 100%*
 - At age 72 hours, minimum 100%*

*Compared to strengths of specimens of the same proportions, consistency, cement and standard 20-30 Ottawa sand.
- Organic Impurities (AASHTO T 21). The color of the supernatant liquid is equal to or lighter than the reference standard solution.

(3) Product Control.

(a) Size Requirements. Provide FA-A that comply with **TABLE 1116-4** or some other gradation approved by the Engineer that will provide a combined aggregate gradation meeting **subsection 1116.2b**.

TABLE 1116-4: GRADING REQUIREMENTS FOR FINE AGGREGATES FOR CONCRETE								
Type	Percent Retained-Square Mesh Sieves							
	3/8"	No. 4	No. 8	No. 16	No. 30	No. 50	No. 100	No. 200
FA-A	0	0-10	0-27	15-55	40-77	70-93	90-100	98-100

(b) Deleterious Substances.

- Type FA-A: Maximum allowed deleterious substances by weight are:
 - Coal (AASHTO T113).....0.5%
 - Sticks (wet) (KT-35).....0.1%
 - Sum of all deleterious0.5%

f. Miscellaneous Aggregates for Concrete.

(1) Aggregates for Mortar Sand, Type FA-M.

(a) Composition. Provide aggregates for mortar sand, Type FA-M that is natural occurring sand.

(b) Quality.

- Mortar strength and Organic Impurities. If the DME determines it is necessary, because of unknown characteristics of new sources or changes in existing sources, provide aggregates for mortar sand, Type FA-M that comply with the following:
 - Mortar Strength (KTMR-26). Compressive strength when combined with Type III (high early strength) cement:
 - At age 24 hours, minimum 100%*
 - At age 72 hours, minimum 100%*

* Compared to strengths of specimens of the same proportions, consistency, cement and standard 20-30 Ottawa sand.
 - Organic Impurities (AASHTO T 21). The color of the supernatant liquid is equal to or lighter than the reference standard solution.

(c) Product Control.

- Size Requirements. Provide aggregates for mortar sand, Type FA-M that comply with **TABLE 1116-5**.

TABLE 1116-5: GRADING REQUIREMENTS FOR MORTAR SAND								
Type	Percent Retained - Square Mesh Sieves							Gradation Factor
	No. 4	No. 8	No. 16	No. 30	No. 50	No. 100	No. 200	
FA-M	0	0-2	0-30	20-50	50-75	90-100	98-100	1.70-2.50

- Deleterious Substances. **Subsection 1116.2a.(4)**, as applicable.

(2) Lightweight Aggregates.

(a) Composition. Provide a lightweight aggregate consisting of expanded shale, clay or slate produced from a uniform deposit of raw material.

(b) Quality.

- Soundness, minimum (KTMR-21) 0.90
- Loss on Ignition 5%

(c) Product Control.

- Size Requirements. Use gradations such as those in **TABLES 1116-3** and **1116-4** which have been shown to work in Optimized Mixed Aggregates, or some other gradation approved by the Engineer that will provide a combined aggregate gradation meeting **subsection 1116.2b**.
- Deleterious Substances. **Subsection 1116.2b.(2)(c)** as applicable.
- Organic Impurities (AASHTO T 21). The color of the supernatant liquid is equal to or lighter than the reference standard solution.
- Unit Weight (dry, loose weight) (max.) 1890 lbs/cu yd

(d) Concrete Making Properties. Drying shrinkage of concrete specimens prepared with lightweight aggregate proportioned as shown in the Contract Documents cannot exceed 0.07%.

(e) Uniformity of Supply. Designate or determine the fineness modulus (grading factor) according to procedure listed in Part V, Section 5.10.5-Fineness Modulus of Aggregates (Gradation Factor) before delivery, or from the first 10 samples tested and accepted. Provide aggregate that is within ± 0.20 of the average fineness modulus.

(f) Proportioning Materials. Submit mix designs for concrete using modified lightweight aggregate to Construction and Materials for approval prior to use.

(g) Stockpiling. Stockpile accepted aggregates in layers 3 to 5 feet thick. Berm each layer so that aggregate do not “cone” down into lower layer.

1116.3 TEST METHODS

Test aggregates according to the applicable provisions of **SECTION 1115**.

1116.4 PREQUALIFICATION

Aggregates for concrete must be prequalified according to **subsection 1101.4**.

1116.5 BASIS OF ACCEPTANCE

The Engineer will accept aggregates for concrete based on the prequalification required by this specification and **subsection 1101.5**.

MOVING AVERAGE

Notice how the individual test result fails in subplot 1D which exceeded the single lower specification limit (LSL). There is also a failure of the moving average in 3D. Read the specifications to determine what, if any, lower and upper specification limits exist for test results and what action is warranted when such an event occurs.

6. QUALITY LEVEL ANALYSIS

6.1. *Quality Level Analysis* is a statistical procedure that provides a method of estimating the percentage of each lot or subplot of material, product item of construction, or completed construction that may be expected to be within specified tolerance limits. This percent within limits is represented by the unshaded areas under the normal curves in **Figure 11**.

6.2. When the specifications require that the percent within limits be established by Quality Level Analysis, the following procedure shall apply:

Terminology:

6.2.1. x_i = the individual values under consideration

6.2.2. n = the number of individual values under consideration

6.2.3. \bar{X} = the arithmetic mean or average of values under consideration. \bar{X} may be expressed as $\Sigma x_i/n$, or the sum of the individual values divided by the number of individual values.

6.2.4. Q_U = Upper Quality Index. Found by subtracting the average \bar{X} from the Upper Specification Limit (USL) and dividing by the sample standard deviation(s).

6.2.5. Q_L = Lower Quality Index. Found by subtracting the Lower Specification Limit (LSL) from the average \bar{X} and dividing by the sample standard deviation (s).

SINGLE-LIMIT SPECIFICATION

DISTRIBUTION OF CHARACTERISTIC OF INTEREST

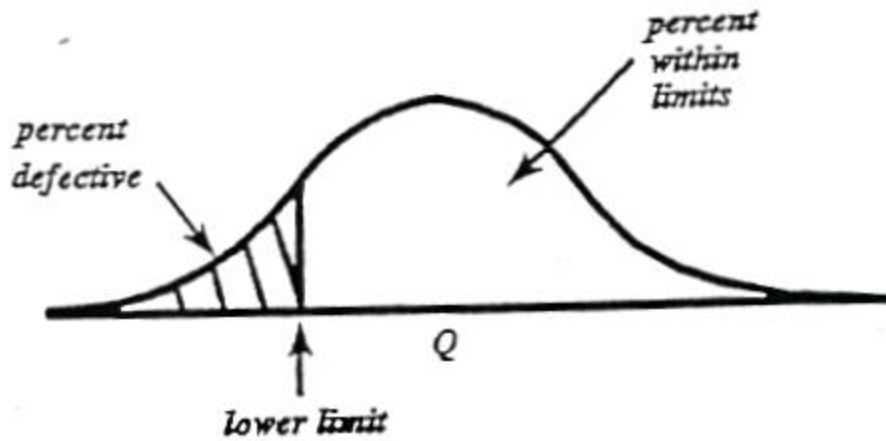

DOUBLE-LIMIT SPECIFICATION

DISTRIBUTION OF CHARACTERISTIC OF INTEREST

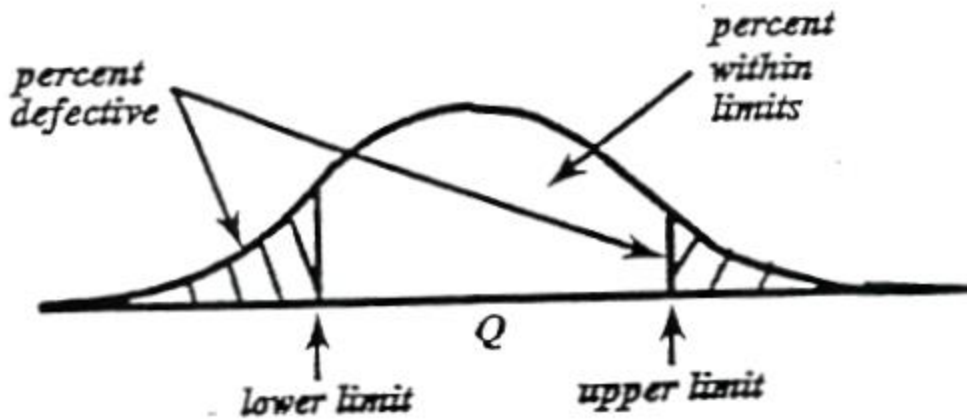

Figure 11. Concept of Percent Defective

6.3. Steps in Analysis for a double-limit specification:

6.3.1. Locate “n” sampling positions on the lot or subplot in a random manner.

6.3.2. Make a measurement at each sample position or take a test portion and make the measurement on the test portion.

6.3.3. Average all measurements to find \bar{x} .

6.3.4. Compute the sample standard deviation using:

$$s = \sqrt{\frac{\sum(x_i - \bar{x})^2}{n - 1}}$$

6.3.5. Find the Upper Quality Index (Q_U) by subtracting the average (\bar{x}) from the Upper Specification Limit (USL) and dividing the result by s .

$$Q_U = \frac{(USL - \bar{x})}{s}$$

6.3.6. Find the Lower Quality Index (Q_L) by subtracting the Lower Specification Limit (LSL) from the average (\bar{x}) and dividing the result by s .

$$Q_L = \frac{(\bar{x} - LSL)}{s}$$

6.3.7. Estimate the percentage that will fall below the Upper Specification limit (PWL_U). This is done by referring to **Table 2** with the computed value of Q_U and then reading the appropriate PWL_U value.

6.3.8. Estimate the percentage that will fall above the Lower Specification Limit (PWL_L).

6.3.9. Determine the Quality Level stated as percent within limits (PWL).

$$PWL = (PWL_U + PWL_L) - 100$$

6.4. Steps in Analysis for a single-limit specification with lower-limit specified:

6.4.1. Locate “n” sampling positions on the lot or subplot in a random manner.

6.4.2. Make a measurement at each sample position or take a test portion and make the measurement on the test portion.

6.4.3. Average all measurements to find \bar{x} .

6.4.4. Compute the sample standard deviation using:

$$s = \sqrt{\frac{\sum(x_i - \bar{x})^2}{n - 1}}$$

6.4.5. Find the Quality Index (Q) by subtracting the Lower Specification Limit (LSL) from the average (\bar{x}) and dividing the result by s.

$$Q = \frac{(\bar{x} - LSL)}{s}$$

6.4.6. Estimate the percentage that will fall above the Specification limit (PWL). This is done by referring to **Table 2** with the computed value of Q and then reading the appropriate PWL value.

6.5. Quality Level Analysis: Example Problem for double-limit specification

A contractor has run air voids tests on five lots of SM-19B. The specification limits for air voids are 4 ± 1.25 %. This sets the lower specification limit (LSL) at 2.75 % ($4 - 1.25$ %) air voids and the upper specification limit (USL) at 5.25 % ($4 + 1.25$ %) air voids. Conduct a Quality Level Analysis and compute the percent within limits.

Lot	Sublot	Percent Air Voids
1	1A	4.30
	1B	3.77
	1C	4.05
	1D	4.80
2	2A	4.90
	2B	5.07
	2C	3.82
	2D	3.53
3	3A	2.67
	3D	2.09
	3C	2.92
	3D	2.56
4	4A	2.39
	4B	2.87
	4C	5.56
	4D	4.74
5	5A	2.36
	5B	2.00
	5C	5.99
	5D	3.73

Solution:

$$\text{Lot 1: } \bar{X} = 4.23, s_x = 0.437, n = 4$$

$$Q_U = \frac{5.25 - 4.23}{0.437} = 2.33 \quad \text{from Table 2 PWLU} = 100 \%$$

$$Q_L = \frac{4.23 - 2.75}{0.437} = 3.39 \quad \text{from Table 2 PWLL} = 100 \%$$

$$\text{PWL} = (100 + 100) - 100 = 100 \%$$

$$\text{Lot 2: } \bar{X} = 4.33, s_x = 0.769, n = 4$$

$$Q_U = \frac{5.25 - 4.33}{0.769} = 1.20 \quad \text{from Table 2 PWLU} = 90 \%$$

$$Q_L = \frac{4.33 - 2.75}{0.769} = 2.05 \quad \text{from Table 2 PWLL} = 100 \%$$

$$\text{PWL} = (90 + 100) - 100 = 90 \%$$

$$\text{Lot 3: } \bar{X} = 2.56, s_x = 0.348, n = 4$$

$$Q_U = \frac{5.25 - 2.56}{0.348} = 7.73 \quad \text{from Table 2 PWLU} = 100 \%$$

$$Q_L = \frac{2.56 - 2.75}{0.348} = -0.55 \quad \text{from Table 2 PWL Table} = 68.33 \%$$

If Q_L is a negative number, the PWL is equal to 100% - (value looked up in **Table 2**)

$$\text{PWL}_L = (100 - 68.33) = 31.67 \%$$

$$\text{PWL} = (100 + 31.67) - 100 = 31.67 \%$$

$$\text{Lot 4: } \bar{X} = 3.89, s_x = 1.506, n = 4$$

$$Q_U = \frac{5.25 - 3.89}{1.506} = 0.90 \quad \text{from Table 2 PWLU} = 80.0 \%$$

$$Q_L = \frac{3.89 - 2.75}{1.506} = 0.76 \quad \text{from Table 2 PWLL} = 75.33 \%$$

$$\text{PWL} = (80.0 + 75.33) - 100 = 55.33 \%$$

Lot 5: $\bar{x} = 3.52, s_x = 1.807, n = 4$

$$Q_U = \frac{5.25 - 3.52}{1.807} = 0.96 \quad \text{from Table 2 PWLU} = 82.0 \%$$

$$Q_L = \frac{3.52 - 2.75}{1.807} = 0.43 \quad \text{from Table 2 PWL}_L = 64.33 \%$$

$$PWL = (82.0 + 64.33) - 100 = 46.33 \%$$

6.6. Quality Level Analysis: Example Problem for single-limit specification

A contractor has made thickness cores on three lots of concrete pavement. The lower specification limit (LSL) is 275 mm. Conduct a Quality Level Analysis and compute the percent within limits.

Lot	Sublot	Thickness (mm)
1	1A	278
	1B	274
	1C	276
	1D	280
	1E	280
2	2A	261
	2B	284
	2C	275
	2D	269
	2E	281
3	3A	293
	3B	288
	3C	297
	3D	299
	3E	290

Solution:

Lot 1: $\bar{x} = 277.6, s_x = 2.608, n = 5$

$$Q = \frac{277.6 - 275}{2.608} = 0.997 \quad \text{from Table 2. PWL} = 83.64 \%$$

Lot 2: $\bar{x} = 274.0, s_x = 9.274, n = 5$

$$Q = \frac{274 - 275}{9.274} = -0.11 \quad \text{from Table 2. PWL}_{\text{Table}} = 53.91 \%$$

If Q is a negative number, the PWL is equal to 100 % - (value looked up in Table 2.)
 $PWL = (100.0 - 53.91) = 46.09 \%$

Lot 3: $\bar{x} = 293.4, s_x = 4.615, n = 5$

$$Q = \frac{293.4 - 275}{4.615} = 3.99 \quad \text{from Table 2. PWL} = 100.00 \%$$

**Table 2 for Estimation of Lot Percent Within Limits
 Variability Unknown Procedure
 Standard Deviation Method**

Quality Index Qu or Ql	Percent Within Limits for Selected Sample Sizes												
	N=3	N=4	N=5	N=6	N=7	N=8	N=9	N=10	N=15	N=20	N=30	N=50	N=100
0.00	50.00	50.00	50.00	50.00	50.00	50.00	50.00	50.00	50.00	50.00	50.00	50.00	50.00
0.01	50.28	50.33	50.36	50.37	50.37	50.38	50.38	50.38	50.39	50.39	50.40	50.40	50.40
0.02	50.55	50.67	50.71	50.73	50.75	50.76	50.76	50.77	50.78	50.79	50.79	50.79	50.80
0.03	50.83	51.00	51.07	51.10	51.12	51.14	51.15	51.15	51.17	51.18	51.19	51.19	51.19
0.04	51.10	51.33	51.42	51.47	51.50	51.51	51.53	51.54	51.56	51.57	51.58	51.59	51.59
0.05	51.38	51.67	51.78	51.84	51.87	51.89	51.91	51.92	51.95	51.96	51.98	51.98	51.99
0.06	51.65	52.00	52.13	52.20	52.24	52.27	52.29	52.30	52.34	52.36	52.37	52.38	52.39
0.07	51.93	52.33	52.49	52.57	52.62	52.65	52.67	52.69	52.73	52.75	52.76	52.78	52.78
0.08	52.21	52.67	52.85	52.94	52.99	53.03	53.05	53.07	53.12	53.14	53.16	53.17	53.18
0.09	52.48	53.00	53.20	53.30	53.37	53.41	53.43	53.46	53.51	53.53	53.55	53.57	53.58
0.10	52.76	53.33	53.56	53.67	53.74	53.78	53.82	53.84	53.90	53.92	53.95	53.96	53.97
0.11	53.04	53.67	53.91	54.04	54.11	54.16	54.20	54.22	54.29	54.31	54.34	54.36	54.37
0.12	53.31	54.00	54.27	54.40	54.49	54.54	54.58	54.60	54.67	54.70	54.73	54.75	54.76
0.13	53.59	54.33	54.62	54.77	54.86	54.92	54.96	54.99	55.06	55.09	55.12	55.14	55.16
0.14	53.87	54.67	54.98	55.14	55.23	55.29	55.34	55.37	55.45	55.48	55.52	55.54	55.55
0.15	54.15	55.00	55.33	55.50	55.60	55.67	55.71	55.75	55.84	55.87	55.91	55.93	55.95
0.16	54.42	55.33	55.69	55.87	55.97	56.04	56.09	56.13	56.22	56.26	56.30	56.32	56.34
0.17	54.70	55.67	56.04	56.23	56.35	56.42	56.47	56.51	56.61	56.65	56.69	56.71	56.73
0.18	54.98	56.00	56.40	56.60	56.72	56.79	56.85	56.89	56.99	57.04	57.08	57.11	57.12
0.19	55.26	56.33	56.75	56.96	57.09	57.17	57.23	57.27	57.38	57.43	57.47	57.50	57.52
0.20	55.54	56.67	57.10	57.32	57.46	57.54	57.60	57.65	57.76	57.81	57.85	57.89	57.91
0.21	55.82	57.00	57.46	57.69	57.83	57.92	57.98	58.03	58.15	58.20	58.24	58.27	58.30
0.22	56.10	57.33	57.81	58.05	58.20	58.29	58.36	58.40	58.53	58.58	58.63	58.66	58.69
0.23	56.38	57.67	58.16	58.41	58.56	58.66	58.73	58.78	58.91	58.97	59.01	59.05	59.07
0.24	56.66	58.00	58.52	58.78	58.93	59.03	59.11	59.16	59.29	59.35	59.40	59.44	59.46
0.25	56.95	58.33	58.87	59.14	59.30	59.41	59.48	59.53	59.67	59.73	59.78	59.82	59.85
0.26	57.23	58.67	59.22	59.50	59.67	59.78	59.85	59.91	60.05	60.11	60.17	60.21	60.23
0.27	57.51	59.00	59.57	59.86	60.03	60.15	60.23	60.28	60.43	60.49	60.55	60.59	60.62
0.28	57.80	59.33	59.92	60.22	60.40	60.52	60.60	60.66	60.81	60.87	60.93	60.97	61.00
0.29	58.08	59.67	60.28	60.58	60.77	60.89	60.97	61.03	61.19	61.25	61.31	61.35	61.38
0.30	58.37	60.00	60.63	60.94	61.13	61.25	61.34	61.40	61.56	61.63	61.69	61.73	61.76
0.31	58.65	60.33	60.98	61.30	61.50	61.62	61.71	61.77	61.94	62.01	62.07	62.11	62.14
0.32	58.94	60.67	61.33	61.66	61.86	61.99	62.08	62.14	62.31	62.38	62.45	62.49	62.52
0.33	59.23	61.00	61.68	62.02	62.22	62.35	62.45	62.51	62.69	62.76	62.82	62.87	62.90
0.34	59.51	61.33	62.03	62.38	62.58	62.72	62.81	62.88	63.06	63.13	63.20	63.25	63.28
0.35	59.80	61.67	62.38	62.73	62.94	63.08	63.18	63.25	63.43	63.51	63.57	63.62	63.65
0.36	60.09	62.00	62.72	63.09	63.31	63.45	63.54	63.62	63.80	63.88	63.95	63.99	64.03
0.37	60.38	62.33	63.07	63.45	63.67	63.81	63.91	63.98	64.17	64.25	64.32	64.37	64.40
0.38	60.67	62.67	63.42	63.80	64.02	64.17	64.27	64.35	64.54	64.62	64.69	64.74	64.77
0.39	60.97	63.00	63.77	64.16	64.38	64.53	64.63	64.71	64.90	64.98	65.06	65.11	65.14
0.40	61.26	63.33	64.12	64.51	64.74	64.89	65.00	65.07	65.27	65.35	65.42	65.47	65.51
0.41	61.55	63.67	64.46	64.86	65.10	65.25	65.36	65.43	65.63	65.72	65.79	65.84	65.88
0.42	61.85	64.00	64.81	65.21	65.45	65.61	65.71	65.79	66.00	66.08	66.15	66.21	66.24
0.43	62.15	64.33	65.15	65.57	65.81	65.96	66.07	66.15	66.36	66.44	66.52	66.57	66.61
0.44	62.44	64.67	65.50	65.92	66.16	66.32	66.43	66.51	66.72	66.80	66.88	66.93	66.97

**Table 2 for Estimation of Lot Percent Within Limits
 Variability Unknown Procedure
 Standard Deviation Method**

Quality Index Qu or Ql	Percent Within Limits for Selected Sample Sizes												
	N=3	N=4	N=5	N=6	N=7	N=8	N=9	N=10	N=15	N=20	N=30	N=50	N=100
0.45	62.74	65.00	65.84	66.27	66.51	66.67	66.79	66.87	67.08	67.16	67.24	67.29	67.33
0.46	63.04	65.33	66.19	66.62	66.87	67.03	67.14	67.22	67.43	67.52	67.60	67.65	67.69
0.47	63.34	65.67	66.53	66.96	67.22	67.38	67.49	67.58	67.79	67.88	67.96	68.01	68.05
0.48	63.65	66.00	66.88	67.31	67.57	67.73	67.85	67.93	68.15	68.23	68.31	68.37	68.40
0.49	63.95	66.33	67.22	67.66	67.92	68.08	68.20	68.28	68.50	68.59	68.67	68.72	68.76
0.50	64.25	66.67	67.56	68.00	68.26	68.43	68.55	68.63	68.85	68.94	69.02	69.07	69.11
0.51	64.56	67.00	67.90	68.35	68.61	68.78	68.90	68.98	69.20	69.29	69.37	69.43	69.46
0.52	64.87	67.33	68.24	68.69	68.96	69.13	69.24	69.33	69.55	69.64	69.72	69.77	69.81
0.53	65.18	67.67	68.58	69.04	69.30	69.47	69.59	69.68	69.90	69.99	70.07	70.12	70.16
0.54	65.49	68.00	68.92	69.38	69.64	69.82	69.93	70.02	70.24	70.33	70.41	70.47	70.51
0.55	65.80	68.33	69.26	69.72	69.99	70.16	70.28	70.36	70.59	70.68	70.76	70.81	70.85
0.56	66.12	68.67	69.60	70.06	70.33	70.50	70.62	70.71	70.93	71.02	71.10	71.15	71.19
0.57	66.43	69.00	69.94	70.40	70.67	70.84	70.96	71.05	71.27	71.36	71.44	71.49	71.53
0.58	66.75	69.33	70.27	70.74	71.01	71.18	71.30	71.39	71.61	71.70	71.78	71.83	71.87
0.59	67.07	69.67	70.61	71.07	71.34	71.52	71.64	71.72	71.95	72.04	72.11	72.17	72.21
0.60	67.39	70.00	70.95	71.41	71.68	71.85	71.97	72.06	72.28	72.37	72.45	72.50	72.54
0.61	67.72	70.33	71.28	71.75	72.02	72.19	72.31	72.40	72.61	72.70	72.78	72.84	72.87
0.62	68.04	70.67	71.61	72.08	72.35	72.52	72.64	72.73	72.95	73.04	73.11	73.17	73.20
0.63	68.37	71.00	71.95	72.41	72.68	72.85	72.97	73.06	73.28	73.37	73.44	73.50	73.53
0.64	68.70	71.33	72.28	72.74	73.01	73.18	73.30	73.39	73.61	73.69	73.77	73.82	73.86
0.65	69.03	71.67	72.61	73.08	73.34	73.51	73.63	73.72	73.93	74.02	74.10	74.15	74.18
0.66	69.37	72.00	72.94	73.40	73.67	73.84	73.96	74.04	74.26	74.34	74.42	74.47	74.51
0.67	69.70	72.33	73.27	73.73	74.00	74.17	74.28	74.37	74.58	74.67	74.74	74.79	74.83
0.68	70.04	72.67	73.60	74.06	74.32	74.49	74.61	74.69	74.90	74.99	75.06	75.11	75.14
0.69	70.39	73.00	73.93	74.39	74.65	74.81	74.93	75.01	75.22	75.30	75.38	75.43	75.46
0.70	70.73	73.33	74.26	74.71	74.97	75.14	75.25	75.33	75.54	75.62	75.69	75.74	75.77
0.71	71.08	73.67	74.59	75.04	75.29	75.46	75.57	75.65	75.85	75.94	76.01	76.05	76.09
0.72	71.43	74.00	74.91	75.36	75.61	75.77	75.89	75.97	76.17	76.25	76.32	76.36	76.40
0.73	71.78	74.33	75.24	75.68	75.93	76.09	76.20	76.28	76.48	76.56	76.63	76.67	76.70
0.74	72.14	74.67	75.56	76.00	76.25	76.41	76.51	76.59	76.79	76.87	76.93	76.98	77.01
0.75	72.50	75.00	75.89	76.32	76.56	76.72	76.83	76.90	77.10	77.17	77.24	77.28	77.31
0.76	72.87	75.33	76.21	76.63	76.88	77.03	77.14	77.21	77.40	77.48	77.54	77.58	77.61
0.77	73.24	75.67	76.53	76.95	77.19	77.34	77.44	77.52	77.70	77.78	77.84	77.88	77.91
0.78	73.61	76.00	76.85	77.26	77.50	77.65	77.75	77.82	78.01	78.08	78.14	78.18	78.21
0.79	73.98	76.33	77.17	77.58	77.81	77.96	78.06	78.13	78.30	78.37	78.43	78.47	78.50
0.80	74.36	76.67	77.49	77.89	78.12	78.26	78.36	78.43	78.60	78.67	78.73	78.77	78.79
0.81	74.75	77.00	77.81	78.20	78.42	78.56	78.66	78.73	78.90	78.96	79.02	79.06	79.08
0.82	75.14	77.33	78.13	78.51	78.73	78.86	78.96	79.02	79.19	79.25	79.31	79.35	79.37
0.83	75.53	77.67	78.44	78.82	79.03	79.16	79.25	79.32	79.48	79.54	79.60	79.63	79.65
0.84	75.93	78.00	78.76	79.12	79.33	79.46	79.55	79.61	79.77	79.83	79.88	79.91	79.94
0.85	76.33	78.33	79.07	79.43	79.63	79.76	79.84	79.90	80.06	80.11	80.16	80.20	80.22
0.86	76.74	78.67	79.38	79.73	79.93	80.05	80.13	80.19	80.34	80.40	80.44	80.47	80.49
0.87	77.16	79.00	79.69	80.03	80.22	80.34	80.42	80.48	80.62	80.68	80.72	80.75	80.77
0.88	77.58	79.33	80.00	80.33	80.52	80.63	80.71	80.77	80.90	80.95	81.00	81.02	81.04
0.89	78.01	79.67	80.31	80.63	80.81	80.92	81.00	81.05	81.18	81.23	81.27	81.30	81.31

**Table 2 for Estimation of Lot Percent Within Limits
 Variability Unknown Procedure
 Standard Deviation Method**

Quality Index Qu or Ql	Percent Within Limits for Selected Sample Sizes												
	N=3	N=4	N=5	N=6	N=7	N=8	N=9	N=10	N=15	N=20	N=30	N=50	N=100
0.90	78.45	80.00	80.62	80.93	81.10	81.21	81.28	81.33	81.46	81.50	81.54	81.57	81.58
0.91	78.89	80.33	80.93	81.22	81.39	81.49	81.56	81.61	81.73	81.77	81.81	81.83	81.85
0.92	79.34	80.67	81.23	81.51	81.67	81.77	81.84	81.89	82.00	82.04	82.08	82.10	82.11
0.93	79.81	81.00	81.54	81.81	81.96	82.05	82.12	82.16	82.27	82.31	82.34	82.36	82.37
0.94	80.27	81.33	81.84	82.10	82.24	82.33	82.39	82.44	82.54	82.57	82.60	82.62	82.63
0.95	80.75	81.67	82.14	82.39	82.52	82.61	82.67	82.71	82.80	82.84	82.86	82.88	82.89
0.96	81.25	82.00	82.45	82.67	82.80	82.88	82.94	82.97	83.06	83.10	83.12	83.13	83.14
0.97	81.75	82.33	82.75	82.96	83.08	83.15	83.21	83.24	83.32	83.35	83.37	83.39	83.39
0.98	82.26	82.67	83.04	83.24	83.35	83.43	83.47	83.51	83.58	83.61	83.63	83.64	83.64
0.99	82.79	83.00	83.34	83.52	83.63	83.69	83.74	83.77	83.84	83.86	83.88	83.88	83.89
1.00	83.33	83.33	83.64	83.80	83.90	83.96	84.00	84.03	84.09	84.11	84.12	84.13	84.13
1.01	83.89	83.67	83.93	84.08	84.17	84.22	84.26	84.28	84.34	84.36	84.37	84.37	84.38
1.02	84.47	84.00	84.22	84.36	84.44	84.49	84.52	84.54	84.59	84.60	84.61	84.62	84.62
1.03	85.07	84.33	84.52	84.63	84.70	84.75	84.77	84.79	84.83	84.85	84.85	84.85	84.85
1.04	85.69	84.67	84.81	84.91	84.97	85.00	85.03	85.04	85.08	85.09	85.09	85.09	85.09
1.05	86.34	85.00	85.09	85.18	85.23	85.26	85.28	85.29	85.32	85.33	85.33	85.32	85.32
1.06	87.02	85.33	85.38	85.45	85.49	85.51	85.53	85.54	85.56	85.56	85.56	85.55	85.55
1.07	87.73	85.67	85.67	85.71	85.74	85.76	85.78	85.78	85.80	85.80	85.79	85.78	85.78
1.08	88.49	86.00	85.95	85.98	86.00	86.01	86.02	86.03	86.03	86.03	86.02	86.01	86.00
1.09	89.29	86.33	86.24	86.24	86.25	86.26	86.27	86.27	86.26	86.26	86.25	86.23	86.23
1.10	90.16	86.67	86.52	86.50	86.51	86.51	86.51	86.50	86.49	86.48	86.47	86.46	86.45
1.11	91.11	87.00	86.80	86.76	86.75	86.75	86.74	86.74	86.72	86.71	86.69	86.68	86.66
1.12	92.18	87.33	87.07	87.02	87.00	86.99	86.98	86.97	86.95	86.93	86.91	86.89	86.88
1.13	93.40	87.67	87.35	87.28	87.25	87.23	87.21	87.20	87.17	87.15	87.13	87.11	87.09
1.14	94.92	88.00	87.63	87.53	87.49	87.46	87.45	87.43	87.39	87.37	87.34	87.32	87.30
1.15	97.13	88.33	87.90	87.78	87.73	87.70	87.68	87.66	87.61	87.58	87.55	87.53	87.51
1.16	100.00	88.67	88.17	88.03	87.97	87.93	87.90	87.88	87.82	87.79	87.76	87.74	87.72
1.17	100.00	89.00	88.44	88.28	88.21	88.16	88.13	88.10	88.04	88.00	87.97	87.94	87.92
1.18	100.00	89.33	88.71	88.53	88.44	88.39	88.35	88.32	88.25	88.21	88.18	88.15	88.12
1.19	100.00	89.67	88.98	88.77	88.67	88.61	88.57	88.54	88.46	88.42	88.38	88.35	88.32
1.20	100.00	90.00	89.24	89.01	88.90	88.83	88.79	88.76	88.66	88.62	88.58	88.54	88.52
1.21	100.00	90.33	89.50	89.25	89.13	89.06	89.00	88.97	88.87	88.82	88.78	88.74	88.71
1.22	100.00	90.67	89.77	89.49	89.35	89.27	89.22	89.18	89.07	89.02	88.97	88.93	88.91
1.23	100.00	91.00	90.03	89.72	89.58	89.49	89.43	89.39	89.27	89.22	89.16	89.12	89.09
1.24	100.00	91.33	90.28	89.96	89.80	89.70	89.64	89.59	89.47	89.41	89.36	89.31	89.28
1.25	100.00	91.67	90.54	90.19	90.02	89.91	89.85	89.79	89.66	89.60	89.54	89.50	89.47
1.26	100.00	92.00	90.79	90.42	90.23	90.12	90.05	90.00	89.85	89.79	89.73	89.68	89.65
1.27	100.00	92.33	91.04	90.64	90.45	90.33	90.25	90.19	90.04	89.98	89.91	89.87	89.83
1.28	100.00	92.67	91.29	90.87	90.66	90.53	90.45	90.39	90.23	90.16	90.10	90.05	90.01
1.29	100.00	93.00	91.54	91.09	90.87	90.74	90.65	90.58	90.42	90.34	90.28	90.22	90.18
1.30	100.00	93.33	91.79	91.31	91.07	90.94	90.84	90.78	90.60	90.52	90.45	90.40	90.36
1.31	100.00	93.67	92.03	91.52	91.28	91.13	91.04	90.97	90.78	90.70	90.63	90.57	90.53
1.32	100.00	94.00	92.27	91.74	91.48	91.33	91.23	91.15	90.96	90.88	90.80	90.74	90.70
1.33	100.00	94.33	92.51	91.95	91.68	91.52	91.41	91.34	91.14	91.05	90.97	90.91	90.87
1.34	100.00	94.67	92.75	92.16	91.88	91.71	91.60	91.52	91.31	91.22	91.14	91.08	91.03

**Table 2 for Estimation of Lot Percent Within Limits
 Variability Unknown Procedure
 Standard Deviation Method**

Quality Index Qu or Ql	Percent Within Limits for Selected Sample Sizes												
	N=3	N=4	N=5	N=6	N=7	N=8	N=9	N=10	N=15	N=20	N=30	N=50	N=100
1.35	100.00	95.00	92.98	92.37	92.08	91.90	91.78	91.70	91.48	91.39	91.31	91.24	91.19
1.36	100.00	95.33	93.21	92.58	92.27	92.09	91.96	91.88	91.65	91.56	91.47	91.40	91.35
1.37	100.00	95.67	93.44	92.78	92.46	92.27	92.14	92.05	91.82	91.72	91.63	91.56	91.51
1.38	100.00	96.00	93.67	92.98	92.65	92.45	92.32	92.23	91.99	91.88	91.79	91.72	91.67
1.39	100.00	96.33	93.90	93.18	92.83	92.63	92.49	92.40	92.15	92.04	91.95	91.88	91.82
1.40	100.00	96.67	94.12	93.37	93.02	92.81	92.67	92.56	92.31	92.20	92.10	92.03	91.98
1.41	100.00	97.00	94.34	93.57	93.20	92.98	92.83	92.73	92.47	92.36	92.26	92.18	92.13
1.42	100.00	97.33	94.56	93.76	93.38	93.15	93.00	92.90	92.63	92.51	92.41	92.33	92.27
1.43	100.00	97.67	94.77	93.95	93.55	93.32	93.17	93.06	92.78	92.66	92.56	92.48	92.42
1.44	100.00	98.00	94.98	94.13	93.73	93.49	93.33	93.22	92.93	92.81	92.70	92.62	92.56
1.45	100.00	98.33	95.19	94.32	93.90	93.65	93.49	93.37	93.08	92.96	92.85	92.76	92.70
1.46	100.00	98.67	95.40	94.50	94.07	93.81	93.65	93.53	93.23	93.10	92.99	92.90	92.84
1.47	100.00	99.00	95.61	94.67	94.23	93.97	93.80	93.68	93.37	93.25	93.13	93.04	92.98
1.48	100.00	99.33	95.81	94.85	94.40	94.13	93.96	93.83	93.52	93.39	93.27	93.18	93.12
1.49	100.00	99.67	96.01	95.02	94.56	94.29	94.11	93.98	93.66	93.52	93.40	93.31	93.25
1.50	100.00	100.00	96.20	95.19	94.72	94.44	94.26	94.13	93.80	93.66	93.54	93.45	93.38
1.51	100.00	100.00	96.39	95.36	94.87	94.59	94.40	94.27	93.94	93.80	93.67	93.58	93.51
1.52	100.00	100.00	96.58	95.53	95.03	94.74	94.55	94.41	94.07	93.93	93.80	93.71	93.64
1.53	100.00	100.00	96.77	95.69	95.18	94.88	94.69	94.55	94.20	94.06	93.93	93.83	93.76
1.54	100.00	100.00	96.95	95.85	95.33	95.03	94.83	94.69	94.33	94.19	94.05	93.96	93.89
1.55	100.00	100.00	97.13	96.00	95.48	95.17	94.97	94.82	94.46	94.31	94.18	94.08	94.01
1.56	100.00	100.00	97.31	96.16	95.62	95.31	95.10	94.95	94.59	94.44	94.30	94.20	94.13
1.57	100.00	100.00	97.48	96.31	95.76	95.44	95.23	95.08	94.71	94.56	94.42	94.32	94.25
1.58	100.00	100.00	97.65	96.46	95.90	95.58	95.36	95.21	94.84	94.68	94.54	94.44	94.36
1.59	100.00	100.00	97.81	96.60	96.04	95.71	95.49	95.34	94.96	94.80	94.66	94.55	94.48
1.60	100.00	100.00	97.97	96.75	96.17	95.84	95.62	95.46	95.08	94.92	94.77	94.67	94.59
1.61	100.00	100.00	98.13	96.89	96.31	95.97	95.74	95.59	95.19	95.03	94.88	94.78	94.70
1.62	100.00	100.00	98.28	97.03	96.43	96.09	95.86	95.70	95.31	95.14	94.99	94.89	94.81
1.63	100.00	100.00	98.43	97.16	96.56	96.21	95.98	95.82	95.42	95.25	95.10	94.99	94.92
1.64	100.00	100.00	98.58	97.29	96.69	96.33	96.10	95.94	95.53	95.36	95.21	95.10	95.02
1.65	100.00	100.00	98.72	97.42	96.81	96.45	96.22	96.05	95.64	95.47	95.32	95.21	95.13
1.66	100.00	100.00	98.85	97.55	96.93	96.57	96.33	96.16	95.75	95.57	95.42	95.31	95.23
1.67	100.00	100.00	98.98	97.67	97.05	96.68	96.44	96.27	95.85	95.68	95.52	95.41	95.33
1.68	100.00	100.00	99.11	97.79	97.16	96.79	96.55	96.38	95.95	95.78	95.62	95.51	95.43
1.69	100.00	100.00	99.23	97.91	97.27	96.90	96.66	96.48	96.06	95.88	95.72	95.61	95.53
1.70	100.00	100.00	99.34	98.02	97.38	97.01	96.76	96.59	96.16	95.98	95.82	95.70	95.62
1.71	100.00	100.00	99.45	98.13	97.49	97.11	96.86	96.69	96.25	96.07	95.91	95.80	95.71
1.72	100.00	100.00	99.55	98.24	97.59	97.21	96.97	96.79	96.35	96.17	96.01	95.89	95.81
1.73	100.00	100.00	99.64	98.34	97.70	97.31	97.06	96.89	96.44	96.26	96.10	95.98	95.90
1.74	100.00	100.00	99.73	98.45	97.80	97.41	97.16	96.98	96.54	96.35	96.19	96.07	95.99
1.75	100.00	100.00	99.81	98.55	97.89	97.51	97.25	97.07	96.63	96.44	96.28	96.16	96.07
1.76	100.00	100.00	99.88	98.64	97.99	97.60	97.35	97.17	96.72	96.53	96.37	96.24	96.16
1.77	100.00	100.00	99.94	98.73	98.08	97.69	97.44	97.26	96.80	96.62	96.45	96.33	96.24
1.78	100.00	100.00	99.98	98.82	98.17	97.78	97.53	97.34	96.89	96.70	96.53	96.41	96.33
1.79	100.00	100.00	100.00	98.91	98.26	97.87	97.61	97.43	96.97	96.79	96.62	96.49	96.41

**Table 2 for Estimation of Lot Percent Within Limits
 Variability Unknown Procedure
 Standard Deviation Method**

Quality Index Qu or Ql	Percent Within Limits for Selected Sample Sizes												
	N=3	N=4	N=5	N=6	N=7	N=8	N=9	N=10	N=15	N=20	N=30	N=50	N=100
1.80	100.00	100.00	100.00	98.99	98.35	97.96	97.70	97.51	97.06	96.87	96.70	96.57	96.49
1.81	100.00	100.00	100.00	99.07	98.43	98.04	97.78	97.60	97.14	96.95	96.78	96.65	96.57
1.82	100.00	100.00	100.00	99.15	98.51	98.12	97.86	97.68	97.21	97.02	96.85	96.73	96.64
1.83	100.00	100.00	100.00	99.22	98.59	98.20	97.94	97.75	97.29	97.10	96.93	96.81	96.72
1.84	100.00	100.00	100.00	99.29	98.66	98.28	98.02	97.83	97.37	97.18	97.01	96.88	96.79
1.85	100.00	100.00	100.00	99.36	98.74	98.35	98.09	97.91	97.44	97.25	97.08	96.95	96.87
1.86	100.00	100.00	100.00	99.43	98.81	98.42	98.16	97.98	97.52	97.32	97.15	97.03	96.94
1.87	100.00	100.00	100.00	99.49	98.88	98.49	98.24	98.05	97.59	97.39	97.22	97.10	97.01
1.88	100.00	100.00	100.00	99.54	98.94	98.56	98.30	98.12	97.66	97.46	97.29	97.17	97.08
1.89	100.00	100.00	100.00	99.60	99.01	98.63	98.37	98.19	97.72	97.53	97.36	97.23	97.15
1.90	100.00	100.00	100.00	99.65	99.07	98.69	98.44	98.25	97.79	97.60	97.43	97.30	97.21
1.91	100.00	100.00	100.00	99.70	99.13	98.76	98.50	98.32	97.86	97.66	97.49	97.37	97.28
1.92	100.00	100.00	100.00	99.74	99.19	98.82	98.56	98.38	97.92	97.73	97.55	97.43	97.34
1.93	100.00	100.00	100.00	99.78	99.24	98.88	98.63	98.44	97.98	97.79	97.62	97.49	97.40
1.94	100.00	100.00	100.00	99.82	99.30	98.93	98.68	98.50	98.04	97.85	97.68	97.55	97.46
1.95	100.00	100.00	100.00	99.85	99.35	98.99	98.74	98.56	98.10	97.91	97.74	97.61	97.52
1.96	100.00	100.00	100.00	99.88	99.40	99.04	98.80	98.62	98.16	97.97	97.80	97.67	97.58
1.97	100.00	100.00	100.00	99.91	99.44	99.09	98.85	98.67	98.22	98.03	97.86	97.73	97.64
1.98	100.00	100.00	100.00	99.93	99.49	99.14	98.90	98.73	98.27	98.08	97.91	97.79	97.70
1.99	100.00	100.00	100.00	99.95	99.53	99.19	98.95	98.78	98.33	98.14	97.97	97.84	97.75
2.00	100.00	100.00	100.00	99.97	99.57	99.24	99.00	98.83	98.38	98.19	98.02	97.90	97.81
2.01	100.00	100.00	100.00	99.98	99.61	99.28	99.05	98.88	98.43	98.24	98.07	97.95	97.86
2.02	100.00	100.00	100.00	99.99	99.64	99.33	99.10	98.93	98.48	98.29	98.13	98.00	97.91
2.03	100.00	100.00	100.00	100.00	99.68	99.37	99.14	98.97	98.53	98.34	98.18	98.05	97.96
2.04	100.00	100.00	100.00	100.00	99.71	99.41	99.18	99.02	98.58	98.39	98.23	98.10	98.01
2.05	100.00	100.00	100.00	100.00	99.74	99.45	99.23	99.06	98.63	98.44	98.27	98.15	98.06
2.06	100.00	100.00	100.00	100.00	99.77	99.48	99.27	99.10	98.67	98.49	98.32	98.20	98.11
2.07	100.00	100.00	100.00	100.00	99.79	99.52	99.30	99.14	98.72	98.53	98.37	98.24	98.16
2.08	100.00	100.00	100.00	100.00	99.82	99.55	99.34	99.18	98.76	98.58	98.41	98.29	98.21
2.09	100.00	100.00	100.00	100.00	99.84	99.58	99.38	99.22	98.80	98.62	98.46	98.34	98.25
2.10	100.00	100.00	100.00	100.00	99.86	99.61	99.41	99.26	98.84	98.66	98.50	98.38	98.29
2.11	100.00	100.00	100.00	100.00	99.88	99.64	99.45	99.29	98.88	98.70	98.54	98.42	98.34
2.12	100.00	100.00	100.00	100.00	99.90	99.67	99.48	99.33	98.92	98.74	98.58	98.46	98.38
2.13	100.00	100.00	100.00	100.00	99.92	99.70	99.51	99.36	98.96	98.78	98.62	98.50	98.42
2.14	100.00	100.00	100.00	100.00	99.93	99.72	99.54	99.39	99.00	98.82	98.66	98.54	98.46
2.15	100.00	100.00	100.00	100.00	99.94	99.74	99.57	99.42	99.03	98.86	98.70	98.58	98.50
2.16	100.00	100.00	100.00	100.00	99.95	99.77	99.59	99.45	99.07	98.90	98.74	98.62	98.54
2.17	100.00	100.00	100.00	100.00	99.96	99.79	99.62	99.48	99.10	98.93	98.78	98.66	98.58
2.18	100.00	100.00	100.00	100.00	99.97	99.81	99.64	99.51	99.13	98.97	98.81	98.70	98.61
2.19	100.00	100.00	100.00	100.00	99.98	99.83	99.67	99.54	99.17	99.00	98.85	98.73	98.65
2.20	100.00	100.00	100.00	100.00	99.99	99.84	99.69	99.56	99.20	99.03	98.88	98.77	98.69
2.21	100.00	100.00	100.00	100.00	99.99	99.86	99.71	99.59	99.23	99.06	98.91	98.80	98.72
2.22	100.00	100.00	100.00	100.00	99.99	99.87	99.73	99.61	99.26	99.10	98.95	98.83	98.75
2.23	100.00	100.00	100.00	100.00	100.00	99.89	99.75	99.63	99.29	99.13	98.98	98.87	98.79
2.24	100.00	100.00	100.00	100.00	100.00	99.90	99.77	99.66	99.31	99.15	99.01	98.90	98.82

**Table 2 for Estimation of Lot Percent Within Limits
 Variability Unknown Procedure
 Standard Deviation Method**

Quality Index Qu or Ql	Percent Within Limits for Selected Sample Sizes												
	N=3	N=4	N=5	N=6	N=7	N=8	N=9	N=10	N=15	N=20	N=30	N=50	N=100
2.25	100.00	100.00	100.00	100.00	100.00	99.91	99.79	99.68	99.34	99.18	99.04	98.93	98.85
2.26	100.00	100.00	100.00	100.00	100.00	99.92	99.80	99.70	99.37	99.21	99.07	98.96	98.88
2.27	100.00	100.00	100.00	100.00	100.00	99.93	99.82	99.71	99.39	99.24	99.10	98.99	98.91
2.28	100.00	100.00	100.00	100.00	100.00	99.94	99.83	99.73	99.42	99.26	99.12	99.02	98.94
2.29	100.00	100.00	100.00	100.00	100.00	99.95	99.85	99.75	99.44	99.29	99.15	99.05	98.97
2.30	100.00	100.00	100.00	100.00	100.00	99.96	99.86	99.77	99.46	99.32	99.18	99.07	99.00
2.31	100.00	100.00	100.00	100.00	100.00	99.96	99.87	99.78	99.48	99.34	99.20	99.10	99.03
2.32	100.00	100.00	100.00	100.00	100.00	99.97	99.89	99.80	99.51	99.36	99.23	99.13	99.05
2.33	100.00	100.00	100.00	100.00	100.00	99.98	99.90	99.81	99.53	99.39	99.25	99.15	99.08
2.34	100.00	100.00	100.00	100.00	100.00	99.98	99.91	99.82	99.55	99.41	99.28	99.18	99.10
2.35	100.00	100.00	100.00	100.00	100.00	99.98	99.92	99.84	99.57	99.43	99.30	99.20	99.13
2.36	100.00	100.00	100.00	100.00	100.00	99.99	99.92	99.85	99.58	99.45	99.32	99.22	99.15
2.37	100.00	100.00	100.00	100.00	100.00	99.99	99.93	99.86	99.60	99.47	99.34	99.25	99.18
2.38	100.00	100.00	100.00	100.00	100.00	99.99	99.94	99.87	99.62	99.49	99.37	99.27	99.20
2.39	100.00	100.00	100.00	100.00	100.00	100.00	99.95	99.88	99.64	99.51	99.39	99.29	99.22
2.40	100.00	100.00	100.00	100.00	100.00	100.00	99.95	99.89	99.65	99.53	99.41	99.31	99.25
2.41	100.00	100.00	100.00	100.00	100.00	100.00	99.96	99.90	99.67	99.55	99.43	99.33	99.27
2.42	100.00	100.00	100.00	100.00	100.00	100.00	99.96	99.91	99.68	99.56	99.44	99.35	99.29
2.43	100.00	100.00	100.00	100.00	100.00	100.00	99.97	99.92	99.70	99.58	99.46	99.37	99.31
2.44	100.00	100.00	100.00	100.00	100.00	100.00	99.97	99.92	99.71	99.60	99.48	99.39	99.33
2.45	100.00	100.00	100.00	100.00	100.00	100.00	99.98	99.93	99.73	99.61	99.50	99.41	99.35
2.46	100.00	100.00	100.00	100.00	100.00	100.00	99.98	99.94	99.74	99.63	99.52	99.43	99.37
2.47	100.00	100.00	100.00	100.00	100.00	100.00	99.98	99.94	99.75	99.64	99.53	99.45	99.38
2.48	100.00	100.00	100.00	100.00	100.00	100.00	99.99	99.95	99.76	99.66	99.55	99.46	99.40
2.49	100.00	100.00	100.00	100.00	100.00	100.00	99.99	99.95	99.77	99.67	99.56	99.48	99.42
2.50	100.00	100.00	100.00	100.00	100.00	100.00	99.99	99.96	99.79	99.68	99.58	99.50	99.44
2.51	100.00	100.00	100.00	100.00	100.00	100.00	99.99	99.96	99.80	99.70	99.59	99.51	99.45
2.52	100.00	100.00	100.00	100.00	100.00	100.00	99.99	99.97	99.81	99.71	99.61	99.53	99.47
2.53	100.00	100.00	100.00	100.00	100.00	100.00	100.00	99.97	99.82	99.72	99.62	99.54	99.49
2.54	100.00	100.00	100.00	100.00	100.00	100.00	100.00	99.97	99.83	99.73	99.63	99.56	99.50
2.55	100.00	100.00	100.00	100.00	100.00	100.00	100.00	99.98	99.83	99.74	99.65	99.57	99.52
2.56	100.00	100.00	100.00	100.00	100.00	100.00	100.00	99.98	99.84	99.75	99.66	99.59	99.53
2.57	100.00	100.00	100.00	100.00	100.00	100.00	100.00	99.98	99.85	99.76	99.67	99.60	99.54
2.58	100.00	100.00	100.00	100.00	100.00	100.00	100.00	99.99	99.86	99.77	99.68	99.61	99.56
2.59	100.00	100.00	100.00	100.00	100.00	100.00	100.00	99.99	99.87	99.78	99.70	99.62	99.57
2.60	100.00	100.00	100.00	100.00	100.00	100.00	100.00	99.99	99.87	99.79	99.71	99.64	99.59
2.61	100.00	100.00	100.00	100.00	100.00	100.00	100.00	99.99	99.88	99.80	99.72	99.65	99.60
2.62	100.00	100.00	100.00	100.00	100.00	100.00	100.00	99.99	99.89	99.81	99.73	99.66	99.61
2.63	100.00	100.00	100.00	100.00	100.00	100.00	100.00	99.99	99.89	99.82	99.74	99.67	99.62
2.64	100.00	100.00	100.00	100.00	100.00	100.00	100.00	99.99	99.90	99.83	99.75	99.68	99.63
2.65	100.00	100.00	100.00	100.00	100.00	100.00	100.00	100.00	99.91	99.84	99.76	99.69	99.65
2.66	100.00	100.00	100.00	100.00	100.00	100.00	100.00	100.00	99.91	99.84	99.77	99.70	99.66
2.67	100.00	100.00	100.00	100.00	100.00	100.00	100.00	100.00	99.92	99.85	99.78	99.71	99.67
2.68	100.00	100.00	100.00	100.00	100.00	100.00	100.00	100.00	99.92	99.86	99.78	99.72	99.68
2.69	100.00	100.00	100.00	100.00	100.00	100.00	100.00	100.00	99.93	99.86	99.79	99.73	99.69

**Table 2 for Estimation of Lot Percent Within Limits
Variability Unknown Procedure
Standard Deviation Method**

Quality Index Qu or Ql	Percent Within Limits for Selected Sample Sizes												
	N=3	N=4	N=5	N=6	N=7	N=8	N=9	N=10	N=15	N=20	N=30	N=50	N=100
2.70	100.00	100.00	100.00	100.00	100.00	100.00	100.00	100.00	99.93	99.87	99.80	99.74	99.70
2.71	100.00	100.00	100.00	100.00	100.00	100.00	100.00	100.00	99.94	99.88	99.81	99.75	99.71
2.72	100.00	100.00	100.00	100.00	100.00	100.00	100.00	100.00	99.94	99.88	99.82	99.76	99.72
2.73	100.00	100.00	100.00	100.00	100.00	100.00	100.00	100.00	99.94	99.89	99.82	99.77	99.73
2.74	100.00	100.00	100.00	100.00	100.00	100.00	100.00	100.00	99.95	99.89	99.83	99.78	99.73
2.75	100.00	100.00	100.00	100.00	100.00	100.00	100.00	100.00	99.95	99.90	99.84	99.78	99.74
2.76	100.00	100.00	100.00	100.00	100.00	100.00	100.00	100.00	99.95	99.90	99.84	99.79	99.75
2.77	100.00	100.00	100.00	100.00	100.00	100.00	100.00	100.00	99.96	99.91	99.85	99.80	99.76
2.78	100.00	100.00	100.00	100.00	100.00	100.00	100.00	100.00	99.96	99.91	99.86	99.81	99.77
2.79	100.00	100.00	100.00	100.00	100.00	100.00	100.00	100.00	99.96	99.92	99.86	99.81	99.77
2.80	100.00	100.00	100.00	100.00	100.00	100.00	100.00	100.00	99.97	99.92	99.87	99.82	99.78
2.81	100.00	100.00	100.00	100.00	100.00	100.00	100.00	100.00	99.97	99.93	99.87	99.83	99.79
2.82	100.00	100.00	100.00	100.00	100.00	100.00	100.00	100.00	99.97	99.93	99.88	99.83	99.80
2.83	100.00	100.00	100.00	100.00	100.00	100.00	100.00	100.00	99.97	99.93	99.88	99.84	99.80
2.84	100.00	100.00	100.00	100.00	100.00	100.00	100.00	100.00	99.97	99.94	99.89	99.84	99.81
2.85	100.00	100.00	100.00	100.00	100.00	100.00	100.00	100.00	99.98	99.94	99.89	99.85	99.82
2.86	100.00	100.00	100.00	100.00	100.00	100.00	100.00	100.00	99.98	99.94	99.90	99.86	99.82
2.87	100.00	100.00	100.00	100.00	100.00	100.00	100.00	100.00	99.98	99.95	99.90	99.86	99.83
2.88	100.00	100.00	100.00	100.00	100.00	100.00	100.00	100.00	99.98	99.95	99.91	99.87	99.83
2.89	100.00	100.00	100.00	100.00	100.00	100.00	100.00	100.00	99.98	99.95	99.91	99.87	99.84
2.90	100.00	100.00	100.00	100.00	100.00	100.00	100.00	100.00	99.98	99.95	99.91	99.88	99.84
2.91	100.00	100.00	100.00	100.00	100.00	100.00	100.00	100.00	99.99	99.96	99.92	99.88	99.85
2.92	100.00	100.00	100.00	100.00	100.00	100.00	100.00	100.00	99.99	99.96	99.92	99.88	99.86
2.93	100.00	100.00	100.00	100.00	100.00	100.00	100.00	100.00	99.99	99.96	99.92	99.89	99.86
2.94	100.00	100.00	100.00	100.00	100.00	100.00	100.00	100.00	99.99	99.96	99.93	99.89	99.87
2.95	100.00	100.00	100.00	100.00	100.00	100.00	100.00	100.00	99.99	99.97	99.93	99.90	99.87
2.96	100.00	100.00	100.00	100.00	100.00	100.00	100.00	100.00	99.99	99.97	99.93	99.90	99.87
2.97	100.00	100.00	100.00	100.00	100.00	100.00	100.00	100.00	99.99	99.97	99.94	99.90	99.88
2.98	100.00	100.00	100.00	100.00	100.00	100.00	100.00	100.00	99.99	99.97	99.94	99.91	99.88
2.99	100.00	100.00	100.00	100.00	100.00	100.00	100.00	100.00	99.99	99.97	99.94	99.91	99.89
3.00	100.00	100.00	100.00	100.00	100.00	100.00	100.00	100.00	99.99	99.97	99.95	99.92	99.89
3.01	100.00	100.00	100.00	100.00	100.00	100.00	100.00	100.00	99.99	99.98	99.95	99.92	99.89
3.02	100.00	100.00	100.00	100.00	100.00	100.00	100.00	100.00	99.99	99.98	99.95	99.92	99.90
3.03	100.00	100.00	100.00	100.00	100.00	100.00	100.00	100.00	100.00	99.98	99.95	99.93	99.90
3.04	100.00	100.00	100.00	100.00	100.00	100.00	100.00	100.00	100.00	99.98	99.95	99.93	99.91
3.05	100.00	100.00	100.00	100.00	100.00	100.00	100.00	100.00	100.00	99.98	99.96	99.93	99.91
3.06	100.00	100.00	100.00	100.00	100.00	100.00	100.00	100.00	100.00	99.98	99.96	99.93	99.91
3.07	100.00	100.00	100.00	100.00	100.00	100.00	100.00	100.00	100.00	99.98	99.96	99.94	99.92
3.08	100.00	100.00	100.00	100.00	100.00	100.00	100.00	100.00	100.00	99.99	99.96	99.94	99.92
3.09	100.00	100.00	100.00	100.00	100.00	100.00	100.00	100.00	100.00	99.99	99.96	99.94	99.92
3.10	100.00	100.00	100.00	100.00	100.00	100.00	100.00	100.00	100.00	99.99	99.97	99.94	99.92
3.11	100.00	100.00	100.00	100.00	100.00	100.00	100.00	100.00	100.00	99.99	99.97	99.95	99.93
3.12	100.00	100.00	100.00	100.00	100.00	100.00	100.00	100.00	100.00	99.99	99.97	99.95	99.93
3.13	100.00	100.00	100.00	100.00	100.00	100.00	100.00	100.00	100.00	99.99	99.97	99.95	99.93
3.14	100.00	100.00	100.00	100.00	100.00	100.00	100.00	100.00	100.00	99.99	99.97	99.95	99.93

**Table 2 for Estimation of Lot Percent Within Limits
 Variability Unknown Procedure
 Standard Deviation Method**

Quality Index Qu or Ql	Percent Within Limits for Selected Sample Sizes												
	N=3	N=4	N=5	N=6	N=7	N=8	N=9	N=10	N=15	N=20	N=30	N=50	N=100
3.15	100.00	100.00	100.00	100.00	100.00	100.00	100.00	100.00	100.00	99.99	99.97	99.95	99.94
3.16	100.00	100.00	100.00	100.00	100.00	100.00	100.00	100.00	100.00	99.99	99.98	99.96	99.94
3.17	100.00	100.00	100.00	100.00	100.00	100.00	100.00	100.00	100.00	99.99	99.98	99.96	99.94
3.18	100.00	100.00	100.00	100.00	100.00	100.00	100.00	100.00	100.00	99.99	99.98	99.96	99.94
3.19	100.00	100.00	100.00	100.00	100.00	100.00	100.00	100.00	100.00	99.99	99.98	99.96	99.95
3.20	100.00	100.00	100.00	100.00	100.00	100.00	100.00	100.00	100.00	99.99	99.98	99.96	99.95
3.21	100.00	100.00	100.00	100.00	100.00	100.00	100.00	100.00	100.00	99.99	99.98	99.96	99.95
3.22	100.00	100.00	100.00	100.00	100.00	100.00	100.00	100.00	100.00	99.99	99.98	99.97	99.95
3.23	100.00	100.00	100.00	100.00	100.00	100.00	100.00	100.00	100.00	99.99	99.98	99.97	99.95
3.24	100.00	100.00	100.00	100.00	100.00	100.00	100.00	100.00	100.00	100.00	99.98	99.97	99.96
3.25	100.00	100.00	100.00	100.00	100.00	100.00	100.00	100.00	100.00	100.00	99.98	99.97	99.96
3.26	100.00	100.00	100.00	100.00	100.00	100.00	100.00	100.00	100.00	100.00	99.99	99.97	99.96
3.27	100.00	100.00	100.00	100.00	100.00	100.00	100.00	100.00	100.00	100.00	99.99	99.97	99.96
3.28	100.00	100.00	100.00	100.00	100.00	100.00	100.00	100.00	100.00	100.00	99.99	99.97	99.96
3.29	100.00	100.00	100.00	100.00	100.00	100.00	100.00	100.00	100.00	100.00	99.99	99.98	99.96
3.30	100.00	100.00	100.00	100.00	100.00	100.00	100.00	100.00	100.00	100.00	99.99	99.98	99.96
3.31	100.00	100.00	100.00	100.00	100.00	100.00	100.00	100.00	100.00	100.00	99.99	99.98	99.97
3.32	100.00	100.00	100.00	100.00	100.00	100.00	100.00	100.00	100.00	100.00	99.99	99.98	99.97
3.33	100.00	100.00	100.00	100.00	100.00	100.00	100.00	100.00	100.00	100.00	99.99	99.98	99.97
3.34	100.00	100.00	100.00	100.00	100.00	100.00	100.00	100.00	100.00	100.00	99.99	99.98	99.97
3.35	100.00	100.00	100.00	100.00	100.00	100.00	100.00	100.00	100.00	100.00	99.99	99.98	99.97
3.36	100.00	100.00	100.00	100.00	100.00	100.00	100.00	100.00	100.00	100.00	99.99	99.98	99.97
3.37	100.00	100.00	100.00	100.00	100.00	100.00	100.00	100.00	100.00	100.00	99.99	99.98	99.97
3.38	100.00	100.00	100.00	100.00	100.00	100.00	100.00	100.00	100.00	100.00	99.99	99.98	99.97
3.39	100.00	100.00	100.00	100.00	100.00	100.00	100.00	100.00	100.00	100.00	99.99	99.98	99.98
3.40	100.00	100.00	100.00	100.00	100.00	100.00	100.00	100.00	100.00	100.00	99.99	99.99	99.98
3.41	100.00	100.00	100.00	100.00	100.00	100.00	100.00	100.00	100.00	100.00	99.99	99.99	99.98
3.42	100.00	100.00	100.00	100.00	100.00	100.00	100.00	100.00	100.00	100.00	99.99	99.99	99.98
3.43	100.00	100.00	100.00	100.00	100.00	100.00	100.00	100.00	100.00	100.00	99.99	99.99	99.98
3.44	100.00	100.00	100.00	100.00	100.00	100.00	100.00	100.00	100.00	100.00	99.99	99.99	99.98
3.45	100.00	100.00	100.00	100.00	100.00	100.00	100.00	100.00	100.00	100.00	100.00	99.99	99.98
3.46	100.00	100.00	100.00	100.00	100.00	100.00	100.00	100.00	100.00	100.00	100.00	99.99	99.98
3.47	100.00	100.00	100.00	100.00	100.00	100.00	100.00	100.00	100.00	100.00	100.00	99.99	99.98
3.48	100.00	100.00	100.00	100.00	100.00	100.00	100.00	100.00	100.00	100.00	100.00	99.99	99.98
3.49	100.00	100.00	100.00	100.00	100.00	100.00	100.00	100.00	100.00	100.00	100.00	99.99	99.98
3.50	100.00	100.00	100.00	100.00	100.00	100.00	100.00	100.00	100.00	100.00	100.00	99.99	99.98
3.51	100.00	100.00	100.00	100.00	100.00	100.00	100.00	100.00	100.00	100.00	100.00	99.99	99.99
3.52	100.00	100.00	100.00	100.00	100.00	100.00	100.00	100.00	100.00	100.00	100.00	99.99	99.99
3.53	100.00	100.00	100.00	100.00	100.00	100.00	100.00	100.00	100.00	100.00	100.00	99.99	99.99
3.54	100.00	100.00	100.00	100.00	100.00	100.00	100.00	100.00	100.00	100.00	100.00	99.99	99.99
3.55	100.00	100.00	100.00	100.00	100.00	100.00	100.00	100.00	100.00	100.00	100.00	99.99	99.99
3.56	100.00	100.00	100.00	100.00	100.00	100.00	100.00	100.00	100.00	100.00	100.00	99.99	99.99
3.57	100.00	100.00	100.00	100.00	100.00	100.00	100.00	100.00	100.00	100.00	100.00	99.99	99.99
3.58	100.00	100.00	100.00	100.00	100.00	100.00	100.00	100.00	100.00	100.00	100.00	99.99	99.99
3.59	100.00	100.00	100.00	100.00	100.00	100.00	100.00	100.00	100.00	100.00	100.00	99.99	99.99

**Table 2 for Estimation of Lot Percent Within Limits
 Variability Unknown Procedure
 Standard Deviation Method**

Quality Index Qu or Ql	Percent Within Limits for Selected Sample Sizes												
	N=3	N=4	N=5	N=6	N=7	N=8	N=9	N=10	N=15	N=20	N=30	N=50	N=100
3.60	100.00	100.00	100.00	100.00	100.00	100.00	100.00	100.00	100.00	100.00	100.00	99.99	99.99
3.61	100.00	100.00	100.00	100.00	100.00	100.00	100.00	100.00	100.00	100.00	100.00	100.00	99.99
3.62	100.00	100.00	100.00	100.00	100.00	100.00	100.00	100.00	100.00	100.00	100.00	100.00	99.99
3.63	100.00	100.00	100.00	100.00	100.00	100.00	100.00	100.00	100.00	100.00	100.00	100.00	99.99
3.64	100.00	100.00	100.00	100.00	100.00	100.00	100.00	100.00	100.00	100.00	100.00	100.00	99.99
3.65	100.00	100.00	100.00	100.00	100.00	100.00	100.00	100.00	100.00	100.00	100.00	100.00	99.99
3.66	100.00	100.00	100.00	100.00	100.00	100.00	100.00	100.00	100.00	100.00	100.00	100.00	99.99
3.67	100.00	100.00	100.00	100.00	100.00	100.00	100.00	100.00	100.00	100.00	100.00	100.00	99.99
3.68	100.00	100.00	100.00	100.00	100.00	100.00	100.00	100.00	100.00	100.00	100.00	100.00	99.99
3.69	100.00	100.00	100.00	100.00	100.00	100.00	100.00	100.00	100.00	100.00	100.00	100.00	99.99
3.70	100.00	100.00	100.00	100.00	100.00	100.00	100.00	100.00	100.00	100.00	100.00	100.00	99.99
3.71	100.00	100.00	100.00	100.00	100.00	100.00	100.00	100.00	100.00	100.00	100.00	100.00	99.99
3.72	100.00	100.00	100.00	100.00	100.00	100.00	100.00	100.00	100.00	100.00	100.00	100.00	99.99
3.73	100.00	100.00	100.00	100.00	100.00	100.00	100.00	100.00	100.00	100.00	100.00	100.00	99.99
3.74	100.00	100.00	100.00	100.00	100.00	100.00	100.00	100.00	100.00	100.00	100.00	100.00	99.99
3.75	100.00	100.00	100.00	100.00	100.00	100.00	100.00	100.00	100.00	100.00	100.00	100.00	99.99
3.76	100.00	100.00	100.00	100.00	100.00	100.00	100.00	100.00	100.00	100.00	100.00	100.00	100.00

The estimates of lot percent within limits (PWL) provided in the tables are obtained by numerically integrating the beta distribution function corresponding to Quality Index (Q) and Sample Size (N).

To find PWL from the tables, compute Q from the sample mean and sample standard deviation with unknown population variability, and the lower or upper specification limits.

To find the PWL for a negative Quality Index, first get the PWL for the positive value of the Quality Index from the tables and subtract the result from 100.

**SAMPLING AND TESTING FREQUENCY CHART
CONTRACTOR QUALITY CONTROL TESTING**

CONSTRUCTION OR MATERIAL TYPE 2015 Std. Spec. (SS 2015)	TESTS REQUIRED (RECORDED TO)	TEST METHOD	CODE	QUALITY CONTROL BY CONTRACTOR	CODE	VERIFICATION BY KDOT
DIVISION 300						
CEMENT TREATED BASE (CTB) Sec. 306 & 1105	Sieve Analysis of Aggregate (1%, 0.1% for No. 200 sieve, of mass)	KT-02	c h	1 per day.		1 per week.
	Moisture Tests (0.1 g or 0.01% of mass)	KT-11 or KT-41		4 per day per design.		1 per week.
	Density (0.1 lb/ft ³ or 0.1% of optimum density)	KT-37 or KT-20*		1 per day per design (* KT-20 option is only permitted in conjunction with a fluid mix.)		1 per project per design.
	Compressive Strength (1 psi)	KT-37		1 specimen per subplot		1 specimen per lot.
Completed Base	Field Density Tests (0.1 lb/ft ³ or 0.1% of optimum density)	KT-13 or KT-41		4 per day per design.		1 per week per design.
	Moisture Tests (0.1 g or 0.01% of mass)	KT-11 or KT-41		4 per day per design.		1 per week per design.
DIVISION 500						
PORTLAND CEMENT CONCRETE PAVEMENT Sec. 501 & 503	Sieve Analysis of Aggregate (1%, 0.1% for No. 200 sieve, of mass)	KT-02	c m	1 per 350 TONS of combined aggregate.		1 per project.
	Individual Aggregates Clay Lumps and Friable Particles in Aggregate (0.1 g or 0.01% of mass)	KT-07	c h			As required.

**SAMPLING AND TESTING FREQUENCY CHART
CONTRACTOR QUALITY CONTROL TESTING**

CONSTRUCTION OR MATERIAL TYPE 2015 Std. Spec. (SS 2015)	TESTS REQUIRED (RECORDED TO)	TEST METHOD	CODE	QUALITY CONTROL BY CONTRACTOR	CODE	VERIFICATION BY KDOT
DIVISION 500 (continued)						
PORTLAND CEMENT CONCRETE PAVEMENT Sec. 501 & 503 (continued) Individual Aggregates (continued)	Shale or Shale-Like Materials in Aggregate (0.1 g or 0.01% of mass)	KT-08	c h			As required.
	Sticks in Aggregate (0.01% of mass)	KT-35	c h			As required.
	Unit Weight – lightweight aggregates only (0.1 lb or 0.1% of mass)	KT-05	c k			As required.
	Moisture in Aggregate (0.1 g or 0.01% of mass)	KT-24	p	1 per 1/2 day.		1 per week.
	Coal	AASHTO T 113				As required.
	Organic Impurities	AASHTO T 21				As required.
Concrete	Mass per cubic foot (0.1 lb/ft ³)	KT-20	a	1 per 500 yd ³ .		1 per day.
	Slump (0.25 in)	KT-21	a	1 per 500 yd ³ .		1 per day.
	Temperature (1 °F)	KT-17	a	1 per 500 yd ³ .		1 per day.

**SAMPLING AND TESTING FREQUENCY CHART
CONTRACTOR QUALITY CONTROL TESTING**

CONSTRUCTION OR MATERIAL TYPE 2015 Std. Spec. (SS 2015)	TESTS REQUIRED (RECORDED TO)	TEST METHOD	CODE	QUALITY CONTROL BY CONTRACTOR	CODE	VERIFICATION BY KDOT
DIVISION 500 (continued)						
PORTLAND CEMENT CONCRETE PAVEMENT Sec. 501 & 503 (continued) Concrete (continued)	Air Content (0.25%)	KT-18 or KT-19	a	1 per 500 yd ³ or every 2 hours (mainline), every 4 hours (other slipformed pvmt), whichever is more frequent. Determine the air loss due to paving operations once in the AM and once in the PM. Determine the difference between the air content from concrete sampled before the paver, and concrete sampled behind the paver.		1 per day.
	Density of Fresh Concrete (0.1 lb/ft ³)	KT-38		Initially, 1 complete transverse profile, then 1 density per ½ day.		1 density per week.
	Beams (1 psi)	KT-22 & KT-23		1 set of 3 as required for opening to traffic.		1 set of 3 per week as required for opening to traffic.
	Cores (1 lbf, 0.01 in, 1 psi)	KT-49		As required in SS 2015 section 501.5g.		Thickness measurement and compression test – 1 per lot.

**SAMPLING AND TESTING FREQUENCY CHART
CONTRACTOR QUALITY CONTROL TESTING**

CONSTRUCTION OR MATERIAL TYPE 2015 Std. Spec. (SS 2015)	TESTS REQUIRED (RECORDED TO)	TEST METHOD	CODE	QUALITY CONTROL BY CONTRACTOR	CODE	VERIFICATION BY KDOT
DIVISION 500 (continued)						
PORTLAND CEMENT CONCRETE PAVEMENT Sec. 501 & 503 (continued) Concrete (continued)	Air Void Analyzer (0.0001 in)	KT-71		Prequalification of mix required as per SS 2015 sec. 403.4.		1 test randomly during every 4 weeks of production.
	Permeability (0.01%, KT-73; 10 coulomb, AASHTO T 277; nearest 0.1 kΩ-cm, KT-79	KT-73 or AASHTO T 277 or KT-79	o			1 per mix design per project.
	Profilograph	KT-46		2 tracks per 12 ft of width for the full length of the project.		At the Engineer's discretion.
	Vibrator Frequency Per Standard Specification 154.2e	SS 154.2e		Every 4 hours		Daily
ON-GRADE CONCRETE (OGCA)						See 5.6 Section 5.4.4 of this manual.

SAMPLING AND TESTING FREQUENCY CHART
QUALITY CONTROL/QUALITY ASSURANCE SPECIFICATIONS

<u>CODE</u>	<u>INSTRUCTION</u>
a	The contractor may reduce the sampling and testing frequency to one test per 1,000 yd ³ provided the first two tests each day show compliance with the specification requirements.
b	Sampled by the district field personnel, or contractor and tested at KDOT Central Materials Laboratory (Materials and Research Center).
c	The aggregate producer's tests may be used for quality control purposes if the tests were performed by an appropriately certified technician. In such cases, the contractor shall perform testing as necessary to determine the degrading effects of hauling and stockpiling on the individual aggregates. For CTB, the minimum testing frequency shall be every 4,000 Tons.
d	At least one Modified Lottman test is required weekly. When more than 10,000 Tons of production occurs in a week, then run additional tests to meet the requirement of 1 test per 10,000 Tons.
e	Specification compliance will be determined on a producer basis not on a project basis. Producer and product testing frequency is maintained in AWP. Start with one in three loads, then generally, the sampling frequency will be reduced to one sample per six loads and then per twelve loads if test results determined by the Department show satisfactory compliance of the material with the specifications.
f	Determine the Sand Equivalent (SE) value on the combined virgin aggregates on the first lot of production and then frequency may be reduced to one test per week provided the SE value exceeds the minimum specified value by five (5) percentage points. The frequency may be reduced to one test per two weeks provided the SE value exceeds the minimum specified value by 25 percentage points. When any test (including verification and assurance) shows the SE value to be less than five (5) percentage points above the specified minimum value then the testing frequency will revert to one per lot until two consecutive tests exceed the minimum specified value by five (5) percentage points.
g	All aggregate types except siliceous gravels and steel slag will be considered to have at least two crushed faces on 100% of the aggregate particles. For mixes containing crushed or uncrushed siliceous gravels or steel slag, determine the Coarse Aggregate Angularity (CAA) value of the combined virgin aggregate of the first lot of production. After three consecutive passing tests, the frequency may be reduced to one per three lots or one per week. If any of the quality control or verification tests fail, the frequency will revert to one per lot until the above criteria for reduced frequency is met.
h	If during the determination of individual aggregate gradation, clay lumps and soft or friable particles, shale or shale-like particles, or sticks are found then perform KT-07, KT-08, and KT-35, respectively, at such frequencies as jointly deemed necessary by the Contractor and the District
i	For small lots [lots with less than 1,000 tons], the number of tests may be reduced (see special provision).
j	Provide access to Contractor owned forced air ignition furnace, ovens, and Superpave Gyrotory compactor, as required, for the State Inspector to perform verification tests.

SAMPLING AND TESTING FREQUENCY CHART
QUALITY CONTROL/QUALITY ASSURANCE SPECIFICATIONS

CODE

INSTRUCTION

- k Engineer's discretion. Frequency of tests shall be agreed upon by the Field Engineer and the District Materials Engineer. Frequency will be governed by field conditions. Written documentation of the agreed upon testing frequency shall be included in the project records.
- l This testing of crushed gravel is only needed to confirm that 35% or less natural sand is used in the traveled way mixes. If 95% or more of crushed gravel is retained on the #8 sieve, then the material must have a minimum Uncompacted Void Content of Coarse Aggregate (UVA) value of 45 when tested in accordance with KT-80. Test at the same frequency as KT-50. Do not use material with a UVA value less than 45.
- m The contractor may reduce the sampling and testing frequency to one test per 2,000 Tons provided the first ten tests show compliance with the specification requirements.
- n If more than one test is performed on the sample, use the average value.
- o Verification method must be the same test method as used for mix design approval.
- p Frequency may be reduced to 1 pre-production verification test per day provided the following are met: 1) Handheld moisture meter is used at least once per every 50 cubic yards of production. 2) The meter has an accuracy of $\pm 0.5\%$ of the pre-production verification test. 3) Moistures obtained from the meter are used to adjust batch-to-batch moisture corrections.
- q KT-58 test requires the average of two (2) gyratory plugs

GENERAL NOTES

- All sampling and testing frequencies listed are minimums. Additional quality control, verification, and assurance tests will be performed, when necessary, to provide effective control the work. When any quality control test result fails to comply with the specification requirements then the next subplot of production after obtaining the failing test results will be sampled and tested, regardless of any lesser frequency specified in this appendix.
- For the AASHTOWare Project (AWP), Acceptance Sampling and Tests have been divided into three sections. Items called "ACC" will be Acceptance Tests and will have a quantity assigned. Items called "INF" and "VER" will be additional tests and they will not be for payment. "ACC" tests make the assignment of tested materials to the contract or mix plant. "Sample Type" must = "ACC" when assignment of a pay quantity is being made. "INF" and "VER" when recording test values for additional acceptance information.
- For QUALITY CONTROL BY CONTRACTOR, AWP uses INF or ACC unless otherwise noted. For VERIFICATION BY KDOT, AWP uses ACC or INF or VER unless otherwise noted. For INDEPENDENT ASSURANCE BY KDOT, AWP uses ASW (Assurance Witness), ASR (Assurance Replicate), and ASP (Assurance Split) unless otherwise noted (see section 5.4.2 of this manual).
- For a better explanation of metric (SI) units, see section 5.9, "Sampling and Test Methods Forward", of this manual.
- All samples will be taken from the place of incorporation into the project unless otherwise noted.